

P&R #8.190JRCC

S-633.01

SOUTH WHITESHELL PROVINCIAL PARK
Environmental Act Proposal
for a
Truck-Haul Lagoon

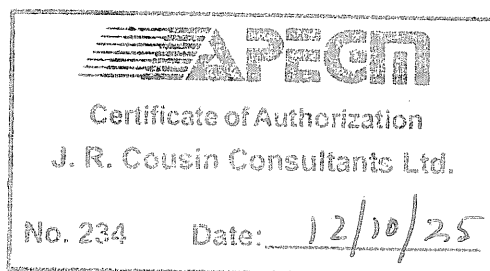

Prepared by:

J. R. Cousin Consultants Ltd.
91 A Scurfield Blvd.
Winnipeg, Manitoba
R3Y 1G4 Ph. (204) 489-0474

October 2012

ACKNOWLEDGMENTS

To prepare this EAP various sources of information were investigated and researched. J. R. Cousin Consultants Ltd. (JRCC) wishes to thank the Parks and Natural Areas Branch of Manitoba Conservation and Manitoba Water Services Board (MWSB) who contributed to the data and content of this report. In addition, we wish to commend Manitoba Conservation for their approach in identifying the need for a long-term solution to wastewater treatment at the South Whiteshell Provincial Park.

REMARKS

J. R. Cousin Consultants Ltd. has conducted this environmental assessment in accordance with generally accepted professional engineering principles and practices for the purpose of identifying conditions that may have an environmental impact on the site. The findings and recommendations reached in this report are based on information made available to JRCC during the investigation and conditions at the time of the site investigation. Conclusions derived from this environmental assessment are intended to reduce, but not wholly eliminate the uncertainty regarding potential environmental concerns on the property, and recognizes reasonable limitations with regards to time, accuracy, work scope and cost. It is possible that environmental conditions may change from the date of this report. If conditions appear different from those encountered and expressed in this report, JRCC should be informed so that mitigation recommendations can be reviewed and adjusted as required. Historical data and information obtained from personal communication used in this report, are assumed to be correct, however JRCC has not conducted further investigations into the accuracy of this data. JRCC has produced this report for the use of the client, and takes no responsibility for any third party decisions or actions based on information contained in this report.

TABLE OF CONTENTS

Section	Page of Section
ENVIRONMENT ACT PROPOSAL FORM	
1.0 INTRODUCTION AND BACKGROUND.....	1
1.1 Contact Information	1
1.2 Background	1
1.3 Description of Previous Studies	2
2.0 DESCRIPTION OF THE DEVELOPMENT	2
2.1 Land Title/Location	2
2.2 Owner of Land and Mineral Rights.....	2
2.3 Existing Land Use	2
2.4 Land Use Designation/Zoning Designation	3
2.5 Description of the Development.....	3
2.5.1 Basis for Proposed Lagoon Site Selection.....	3
2.5.2 Lagoon Drainage Route.....	5
2.5.2.1 Fish Species Information	5
2.5.2.2 Water Quality Information.....	5
2.5.3 Access Road	6
2.5.4 Topography and Geotechnical Review	6
2.5.4.1 Past Geotechnical Investigations	6
2.5.4.2 Current Geotechnical Investigation.....	8
2.5.4.3 Topography	10
2.5.5 Population Contributing Effluent	11
2.5.5.1 Cottage Population.....	11
2.5.5.2 Business, Resorts and Non-profit Populations.....	13
2.5.5.3 Future Growth.....	14
2.5.5.4 Population Summary.....	14
2.5.6 Lagoon Loadings.....	14
2.5.6.1 Current Organic Loadings.....	15
2.5.6.2 Future Organic Loadings	16
2.5.6.3 Organic Loading Summary	16
2.5.6.4 Current Hydraulic Loadings.....	16
2.5.6.5 Future Hydraulic Loadings	17
2.5.6.6 Hydraulic Loading Summary.....	17
2.5.7 Lagoon Size Requirements.....	17
2.5.7.1 Primary Cell.....	18
2.5.7.2 Secondary Cell.....	18
2.5.8 Lagoon Regulatory Requirements.....	19
2.5.8.1 Province of Manitoba Design Objectives	19
2.5.8.2 Nutrient Management Plan	20

Section	Page of Section
2.5.9 Summarized Selected Design Criteria.....	23
2.5.10 Lagoon Layout	24
2.5.11 Lagoon Construction Detail	24
2.5.11.1 General, Conceptual Liner Design and Construction Techniques	24
2.5.11.2 Construction Details.....	25
2.5.12 Lagoon Maintenance	26
3.0 POTENTIAL ENVIRONMENTAL IMPACTS	26
3.1 Releases to Air, Water, Land.....	26
3.1.1 Air.....	26
3.1.2 Water	27
3.1.3 Land.....	27
3.2 Wildlife.....	28
3.3 Fisheries	28
3.4 Surface Water and Groundwater	29
3.5 Forestry.....	29
3.6 Vegetation	29
3.7 Heritage Resources.....	29
3.8 Socio-Economic Implications	30
4.0 MANAGEMENT PRACTICE	30
4.1 Mitigation of Impacts to Air.....	30
4.2 Mitigation of Impacts to Water	30
4.2.1 Surface Water	30
4.2.2 Groundwater.....	31
4.3 Mitigation of Impacts to Land.....	32
5.0 RESIDUAL EFFECTS.....	32
6.0 MONITORING AND FOLLOW-UP.....	33
7.0 RESULTS OF PUBLIC CONSULTATIONS.....	33
8.0 SCHEDULE.....	34
8.1 Commencement Dates.....	34
8.2 Environmental Approval Date.....	34
9.0 FUNDING.....	34

Appendix A

Crown Lands and Property Agency - Lands Branch, February 1, 2012 E-mail Correspondence

Appendix B

Geotechnical and Topographic Investigation for the South Whiteshell Truck-Haul Lagoon

Appendix C

Table 1: Population, Hydraulic and Organic Loading Projections for the South Whiteshell Truck-Haul Lagoon Water Stewardship, January 31, 2012 E-mail Correspondence

Manitoba Water Stewardship, Fisheries Branch, February 13, 2012 E-mail Correspondence

Manitoba Conservation Wildlife and Ecosystem Protection Branch, January 30, 2012 E-mail Correspondence

Manitoba Conservation Historic Resources Branch, February 6, 2012 Memorandum

Appendix D

Title Page

Plan 1: Proposed Lagoon Layout with Test Hole Locations and Topographic Contour Lines

Plan 2: Proposed Lagoon Discharge Route

Plan 3: Proposed Lagoon Layout

Plan 4: Perimeter Dike, Intercell Dike, Valve, Valve Marker, Sign, Rip Rap, Ditch and Access Road Details

Plan 5: Spillway, Truck Turnaround, Silt Fence, Fence, Gate and Lock Details

Environment Act Proposal Form

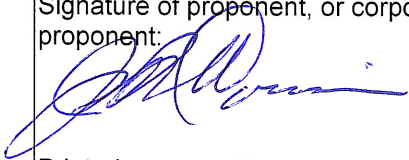
Name of the development: SOUTH WHITESHELL PROVINCIAL PARK TRUCK-HAUL LAGOON	
Type of development per Classes of Development Regulation (Manitoba Regulation 164/88): WASTEWATER TREATMENT LAGOON - CLASS 2 DEVELOPMENT	
Legal name of the proponent of the development: CONSERVATION AND WATER STEWARDSHIP PARKS AND NATURAL AREAS BRANCH	Mailing address: PARKS AND NATURAL AREAS BRANCH 200 SAULT EAUX CRESCENT WINNIPEG, MB R3J 3W3
Location (street address, city, town, municipality, legal description) of the development: SE ¼ of 19-08-16-E	
Name of proponent contact person for purposes of the environmental assessment: MR. JERRY COUSIN	
Phone: (204) 489-0474 Fax: (204) 489-0487	Mailing address: J. R. COUSIN CONSULTANTS LTD. 91A SCURFIELD BLVD. WINNIPEG, MB, R3Y 1G4
Email address: jcousin@jrcc.ca	
Webpage address: www.jrcc.ca	
Date: 12/10/24	Signature of proponent, or corporate principal of corporate proponent:  Printed name: JERRY COUSIN

A complete **Environment Act Proposal (EAP)** consists of the following components:

- **Cover letter**
- **Environment Act Proposal Form**
- **Reports/plans supporting the EAP** (see "Information Bulletin - Environment Act Proposal Report Guidelines" for required information and number of copies)
- **Application fee** (Cheque, payable to Minister of Finance, for the appropriate fee)

Submit the complete EAP to:

Director
Environmental Assessment and Licensing Branch
Manitoba Conservation
Suite 160, 123 Main Street
Winnipeg, Manitoba R3C 1A5

For more information:

Phone: (204) 945-7100
Fax: (204) 945-5229
Toll Free: 1-800-282-8069, ext. 7100
<http://www.gov.mb.ca/conservation/ea>

Per Environment Act Fees Regulation (Manitoba Regulation 168/96):	
Class 1 Developments	\$500
Class 2 Developments	\$5,000
Class 3 Developments:	
Transportation and Transmission Lines.....	\$5,000
Water Developments	\$50,000
Energy and Mining.....	\$100,000

1.0 INTRODUCTION AND BACKGROUND

The development described herein is for the construction of a new truck-haul wastewater treatment lagoon for the South Whiteshell Provincial Park.

1.1 Contact Information

Mr. Jerry Cousin, P.Eng.
J. R. Cousin Consultants Ltd.
91A Scurfield Blvd.
Winnipeg, Manitoba
R3Y 1G4
Phone (204) 489-0474; Fax (204) 489-0487

Mr. Nathan Wittmeier, P. Eng.
Manitoba Water Services Board
P.O. Box 22080
2022 Currie Blvd.
Brandon, Manitoba
R7A 6Y9

1.2 Background

Manitoba Conservation and Water Stewardship Parks and Natural Areas Branch have requested assistance from Manitoba Water Services Board (MWSB) to construct a new wastewater treatment lagoon. The South Whiteshell truck-haul lagoon will service the cottage and business communities serviced by holding tanks and septic tanks in the Falcon Lake Park District (includes Falcon Lake and Barren Lake) and the West Hawk Lake Park District (includes West Hawk, Caddy Lake, Star Lake, Hunt Lake, Florence Lake and Nora Lake). Falcon Lake is located approximately 120 km east of Winnipeg and approximately 12 km from the Manitoba-Ontario border. West Hawk is located approximately 130 km east of Winnipeg and approximately 5 km from the Manitoba-Ontario border.

Currently, South Whiteshell is serviced by two lagoons. The West Hawk lagoon was expanded in 2010 and currently accepts piped wastewater from the West Hawk townsite. The Falcon Lake lagoon was expanded in 2000 and currently accepts piped wastewater from the Falcon Lake townsite and truck-haul wastewater from the West Hawk Lake Park District and the Falcon Lake Park District. A new lagoon is required to accept all the truck-haul wastewater currently accepted by the Falcon Lake lagoon, to alleviate loadings on the lagoon.

1.3 Description of Previous Studies

Description of previous studies and activities relating to feasibility, exploration, or project siting and prior authorization received from other government agencies:

Falcon – West Hawk Truck-haul Lagoon (2007 by Genivar) - The report objectives were to identify the existing organic and hydraulic truck-haul loading to the current wastewater facility and identify the organic and hydraulic capacity required in 2027.

Geotechnical Report – Proposed South Whiteshell Truck-haul WWSP – Falcon Lake, Manitoba (August, 2006 by Cochrane Engineering Ltd.) - The report outlines a geotechnical investigation completed at the proposed lagoon Site.

2.0 DESCRIPTION OF THE DEVELOPMENT

For each heading there is an information request from the Environment Act Proposal Form. These requests are repeated herein in italics followed by the pertaining response.

2.1 Land Title/Location

Certificate of Title showing the owner(s) and legal description of the land upon which the development will be constructed; or, in the case of highways, rail lines, electrical transmission lines, or pipelines, a map or maps at a scale no less than 1:50,000 showing the location of the proposed development:

The proposed lagoon location is southwest of the South Whiteshell Waste Transfer Station located in the SE ¼ of 19-08-16-E. The land is currently part of the Whiteshell Provincial Park.

2.2 Owner of Land and Mineral Rights

Owner of land upon which the development is intended to be constructed, and of mineral rights beneath the land, if different from surface owner:

The proposed development is part of the Whiteshell Provincial Park which is owned by Crown Manitoba. According to the Crown Land Registry, the Mines and Minerals, sand and gravel on the proposed lagoon construction site are owned by Crown Manitoba. The administration and control of these parcels are with the Parks Branch as they are within the Whiteshell Provincial Park boundary (see Email Correspondence dated February 1, 2012, attached in Appendix A).

2.3 Existing Land Use

Existing land use on the site and on land adjoining it, as well as changes that will be made in such land use for the purposes of the development:

The proposed lagoon site consists of forested land bordered by the TransCanada Pipeline to the northwest and the TransCanada Highway to the southeast. The lagoon location is part of the Lake of the Woods ecoregion that reports major land uses as forestry, recreation and hunting.

The lagoon construction is to occur on part of the forested section of the land with access by a road and truck turnaround area. The site would be cleared and grubbed and soil would be excavated at the location of the proposed lagoon for the construction of the dikes and perimeter ditches.

2.4 Land Use Designation/Zoning Designation

Land use designation for the site and adjoining land as identified in a development plan adopted under The Planning Act or The City of Winnipeg Act, and the zoning designation as identified in a zoning by-law, if applicable:

The Whiteshell Provincial Park has a classification of Natural Park according to *A System Plan for Manitoba's Provincial Parks* prepared by the Parks and Natural Areas Branch of Manitoba Conservation. The proposed lagoon site has a land use category designation of Resource Management (RM) that provides recreational opportunities including canoe routes, hiking and cross-country ski trails and also permits mining and wild rice harvesting.

2.5 Description of the Development

Description of proposed development and schedule for stages of the development, including proposed dates for planning, design, construction, commissioning, operation, and decommissioning and/or termination of operation (if known), identifying major components and activities of the development as applicable (e.g. access road, airstrip, processing facility, waste disposal area, etc.).

2.5.1 Basis for Proposed Lagoon Site Selection

The lagoon site was selected due to the

- Abundance of clay
- Flat topography
- Depth to bedrock
- Available discharge route
- Existing road network
- Land already dedicated to Parks infrastructure i.e. waste transfer station (WTS).

Manitoba Conservation's guidelines for the location of a wastewater treatment lagoon (*Design Objectives for Standard Sewage Lagoons*, Province of Manitoba, Environmental Management, July 1985) are outlined in the following table. A description of the proposed sites in relation to each of the guidelines is also provided in the table.

Table 2.1: Proposed Lagoon Site Location in Relation to Manitoba Conservation Guidelines

Manitoba Conservation Guideline	Proposed Relation to Site
1. Lagoons must be located a minimum of 460 m from any community centre, this distance is shown from the proposed lagoon locations on Plan 1, attached in Appendix D.	The proposed new lagoon is located over 2.75 km from the nearest community centre (i.e. Falcon Lake).
2. Lagoons must be located a minimum of 300 m from any residence. (The distance is to be measured from the centreline of the nearest dike).	The proposed new lagoon is located over 2.75 km from the nearest resident.
3. Consideration should be given to sites in which prevailing winds are in the direction of uninhabited areas.	The prevailing winds are from the north and west. The lagoon is located south and west of the community.
4. Sites with an unobstructed wind sweep across the lagoon are preferred.	The site surrounding the proposed lagoon is forested.
5. Areas that are habitually flooded shall be avoided.	The proposed lagoon dikes would be higher than the highest recorded water surface elevation of 325.53 m. A 100 year flood elevation for the Falcon Lake does not exist. (See Water Stewardship E-mail Correspondence, dated January 31, 2012 attached in Appendix C.)
6. Sewage lagoons are to be designed and constructed such that the interior surface of the proposed lagoon is underlain by at least one metre of soil having a hydraulic conductivity of 1×10^{-7} cm/sec or less. In areas sensitive to groundwater contamination, a flexible synthetic liner may be recommended.	Based on the geotechnical investigation, if the in-situ soils are re-worked and re-compacted they will be capable of providing a consistent permeability of 1×10^{-7} cm/sec.

The new lagoon must also comply with setbacks from the TransCanada pipeline and the TransCanada Highway. The TransCanada pipeline was contacted regarding the setback distance from the pipeline which was set at 30 m (100 ft) from the edge of the pipeline

R.O.W. Manitoba Infrastructure and Transportation was contacted regarding the setback distance from the TransCanada highway which was set at 76.2 m (250 ft) from the edge of the R.O.W. These setback distances are shown on Plan 1 attached in Appendix D.

2.5.2 Lagoon Drainage Route

From site observations of the area surrounding the proposed lagoon location, the area is forested with some bog and wetlands. There are no major defined drainage routes or drainage outlets and it is extremely difficult to determine where drainage flows.

Based on a review of drainage maps in the area, aerial photography, conversations with local contractors and the site investigation, drainage from the proposed lagoon is expected to be southwest through a drainage ditch observed during the site investigation that runs from the existing wetlands located southwest of the existing WTS approximately 800 m southwest to a low lying wetlands area. The effluent is expected to flow through the low lying wetlands area into the Talbot Lake that drains through ditches and culverts under the TransCanada Highway. The effluent then travels approximately 380 m through a defined ditch before entering a low lying wetland/bog area. The wetlands is graded south and effluent is expected to flow approximately 5 km (straight line distance) south through the Whiteshell Bog natural wetlands and is expected to enter a first order drain which flows into the Boggy River. The Boggy River flows west to Prawda where it becomes the Birch River. The Birch River flows north into the Lake Winnipeg River System. The expected lagoon drainage route is shown on Plan 2 attached in Appendix D.

2.5.2.1 Fish Species Information

Fish Species present in the Boggy River was obtained from Manitoba Conservation and Water Stewardship Fisheries Branch (see Fisheries Branch Email Correspondence, dated February 13, 2012 in Appendix C). The Boggy River is habitat for two species of concern: northern brook lamprey and carmine shiner. The list of other known fish species includes: northern pike, shorthead redhorse, walleye, white sucker, central mudminnow, pearl dace, mimic shiner, finescale dace, fathead minnow, Johnny darter, brook stickleback, rock bass, blackside darter, common shiner, hornyhead chub, spottail shiner, longnose dace and iowa darter.

2.5.2.2 Water Quality Information

Manitoba Conservation and Water Stewardship was contacted for water quality data in the Boggy River. Summarized water quality from selected parameters are provided below. All samples were retrieved from Station No. MB05PHS011 which is located at the Boggy Creek at WYE Road just south of

the TransCanada Highway. The samples were recorded between February of 1996 and September of 2001. More recent data was not available.

Table 2.2: Average Water Quality in the Boggy River

Parameter	Average Concentration	Unit
Ammonia Dissolved	0.03	mg/L
Coliforms Fecal	22.21	CFU/100ML
Conductivity (at 25C)	126	US/CM
Nitrogen Dissolved NO ₃ & NO ₂	0.03	mg/L
Nitrogen Total Kjeldahl (TKN)	0.71	mg/L
Oxygen Dissolved	6.47	mg/L
Phosphorus Total (P)	0.03	mg/L
Total Dissolved Solids	116.14	mg/L @ 15C
Total Suspended Solids	8.63	mg/L
Turbidity	4.62	NTU

*Parameters listed below the detectable limit were assumed to be at the detectable limit for the purposes of averaging.

Based on the average concentrations shown in Table the River has low nutrient levels in both phosphorus and nitrogen. The River has low conductivity, total suspended solids and total dissolved solids for a surface water body.

2.5.3 Access Road

The proposed lagoon site would be accessed by a new all weather access road that would extend approximately 280 m southeast off the existing WTS access road. This is an existing road that runs off the TransCanada Highway. A truck turnaround area will be constructed at the end of the proposed access road. Construction of the lagoon will increase truck traffic on the existing WTS access road which is not expected to cause problems as the road is designed for heavy truck traffic.

2.5.4 Topography and Geotechnical Review

2.5.4.1 Past Geotechnical Investigations

Cochrane, 2006

A geotechnical investigation was completed by Cochrane Engineering Ltd. in April, 2006 at the proposed lagoon location. A total of seven test holes were excavated utilizing a backhoe. The general soil profile observed was a topsoil/peat layer followed by a thin silty clay layer and a clay layer to the bottom of the test hole (2.4 – 4.6 m below ground). One of the test holes located at the north of the testing area found a sandy till beyond the clay layer.

Two samples from the clay layer and one sample from the silty clay layer were sent for laboratory analysis. The sample from the silty clay layer was deemed a clayey silt with a clay content of 32.1%. The samples from the clay layer had an average Plasticity Index of 36.5 and an average clay content of 68.1%. Although the material was high plastic, in-situ it was deemed not able to meet the Manitoba Conservation guideline of a hydraulic conductivity of 1×10^{-7} cm/sec due to well defined fissures. It was recommended the material be scarified, mixed and compacted to meet the guideline.

JRCC, 1995

A geotechnical investigation was completed by JRCC at and near the existing Falcon Lake Waste Transfer Station (WTS) in February of 1995. A total of five test holes were excavated around the existing WTS site and one test hole was excavated at a potential borrow area. The test hole (TH1) excavated closest to the proposed lagoon location consisted of silty clay to a depth of 1.8 m followed by grey medium to high plastic clay to a depth of 9.4 m followed by low plastic silty clay to a depth of 10.7 m followed by medium plastic silty clay to the bottom of the test hole at 12.2 m. The soil profile of the test holes taken east of the WTS site consisted of a thin layer of sand and gravel followed by medium to high plastic silty clay followed by high plastic clay followed by silty and sandy soils to the bottom of the test holes. No laboratory analysis was completed on the soil samples.

Department of Natural Resources, 1988

A geotechnical investigation for the existing South Whiteshell WTS was completed by the Province of Manitoba's Department of Natural Resources Engineering and Construction Branch in February of 1988. The average soil profile consisted of 0.15 to 1.5 m of topsoil/peat followed by up to 13.4 m of low to medium plastic clay. The upper clay was found to be mainly medium plastic with the low plastic clay occurring below 3.7 – 9.1 m. The Plasticity Index of the medium plastic clay ranged from 23 – 32 with an average of 26.

GW Driller's Well Logs

Driller's Well logs from 21-08-16E were reviewed which are the closest well logs to the proposed lagoon site, approximately 3.2 km east of the site. The well logs indicate the soil profile consists of varying layers of clay, silt and sand underlain with gravel and boulders. Bedrock was encountered in five wells with depths ranging from 2.1 m to 30.8 m. The average static groundwater level recorded in the wells was 2.4 m below the ground surface.

2.5.4.2 Current Geotechnical Investigation

A field investigation was completed on November 9, 2011 to determine the suitability of the proposed site for construction of the lagoon cells and to confirm the results of past soils investigations.

The complete Geotechnical and Topographic Investigation report with appendices is attached in Appendix B.

Test Holes

Nine test holes were excavated during the geotechnical investigation utilizing a track-mounted excavator. Six test holes (TH1 – TH6) were excavated at the proposed lagoon site deemed “Site A” in the report and three test holes (TH7 – TH9) were excavated around a second proposed lagoon site that was not selected and deemed “Site B” in the report.

Soil Profile

The detailed soil profile from TH1 – TH6 taken across Site A consisted of an average of 0.6 m of topsoil followed by an average of 1.3 m of a medium plastic lean clay, soft, grey, fissured/blocky structure with varying levels of silt, sand and trace gravel. The following layer was a medium plastic, firm clay, fissured/blocky structure with silt and trace sand and gravel observed to be an average of 1.4 m thick. The final layer was a medium to high plastic clay, fissured/blocky structure with silt, sand and some gravel observed to a maximum depth of 5.3 m. Bedrock was encountered on TH4 at a depth of 3.4 m.

Groundwater

Short-term groundwater conditions were assessed in each test hole by observing infiltrating water into the test holes prior to backfilling. Caving and sloughing of the test hole walls was also observed and recorded. Slight water infiltration through the test hole walls was observed in TH2 at 1.8 m and slight water infiltration was observed at the test hole bottom in TH3 at 5.1 m. Minor sloughing of the test hole walls was observed in TH2 at 0.6 m, TH3 at 0.8 m and TH7 at 0.5 m.

Groundwater in the test holes depends on high static groundwater conditions and on seasonal conditions, i.e. snowmelt and rainy seasons. Other assumptions relating to the groundwater elevation cannot be made at this time, as water levels will normally fluctuate seasonally.

Laboratory Analysis

Laboratory analysis of the bagged soil samples indicated that three of the soil samples were deemed a lean clay and the other three were deemed a fat clay. The Plasticity Index of the samples varied between 29 and 39 and the percentage of clay varied between 66.1% and 70.3%. Based on past experience, the laboratory has commented that homogeneous soils with a plasticity index greater than 25 and a clay content greater than 50% would typically be expected to have a hydraulic conductivity of 1×10^{-7} cm/sec or less. Plasticity index analysis (i.e. Atterberg limits) of the soils indicated that all of the bagged soil samples submitted were considered to have potential for use as an insitu clay liner or a re-moulded and re-compacted clay liner.

NTL indicates that the bagged soil samples suitability for use as a clay liner is dependent upon the soils being homogeneous with no preferential flow paths. It is also noted that estimating the hydraulic conductivity of a soil based upon classification test results (Plasticity Index and particle size analysis) alone might be misleading if the soil contains layers of sand, silt, or organic material. These silt, and sand layers along with rocks or boulders or fissures in the soil can create preferential flow paths which can lead to an increased hydraulic conductivity.

The bagged soil sample from TH1 0.6 – 2.3 m was re-worked and re-compacted and tested for hydraulic conductivity by the NTL for potential use as a re-worked lagoon liner. The sample achieved a re-worked hydraulic conductivity (k_{20}) of 7.7×10^{-9} cm/sec. The sample had a lower hydraulic conductivity than the Manitoba Conservation requirement of 1×10^{-7} cm/sec and therefore would be suitable for use as a re-worked and re-compacted lagoon liner.

Discussion

Based on the laboratory Plasticity Index analysis, all of the bagged soil samples submitted have potential for use as an insitu lagoon liner or a re-worked and re-compacted lagoon liner.

Based on site observations during the geotechnical investigation the soil samples had layers of silt, sand and gravel and had a blocky, fissured structure which can cause preferential flow paths and increased hydraulic conductivity. Constructing the lagoon with an insitu clay liner would carry significant risk of not meeting the hydraulic conductivity guideline across the site.

When the soil is re-worked and re-compacted the soils are mixed and the structure is altered to create a liner with lower hydraulic conductivity than the insitu soils. The lagoon liner could be constructed by re-working and re-compacting a minimum 1.0 m thick clay liner. The soils at the site were deemed to have potential for use as a re-worked and re-compacted clay liner by laboratory analysis on the bagged samples. This potential was verified by the re-worked and re-compacted Shelby tube sample from TH1 0.6 – 2.3 m which achieved a hydraulic conductivity of 7.7×10^{-9} cm/sec.

If the low plastic clay soils are encountered during liner construction such as the soil layer from TH7 0.5 – 3.1, high plastic clay borrow material may be required to replace the low plastic clay for construction of the lagoon liner.

Depending on final lagoon design elevations, the bedrock encountered on TH4 and TH9 may impact the location of the proposed lagoon.

Overburden soils excavated from the site could be used for the dike construction and medium-high plastic soils from the cell floor area would be excavated and re-compacted and re-worked to create the vertical cut-off walls.

Recommendations

It is recommended that the lagoon liner be constructed by re-working and re-compacting a minimum 1.0 m thick clay liner. The soils at the site were deemed to have potential for use a re-worked and re-compacted clay liner by laboratory analysis on the bagged samples. This potential was verified by the re-worked and re-compacted Shelby tube sample from TH1 0.6 – 2.3 m which achieved a hydraulic conductivity of 7.7×10^{-9} cm/sec.

If the low plastic clay soils are encountered during liner construction such as the soil layer from TH7 0.5 – 3.1, high plastic clay borrow material may be required to replace the low plastic clay for construction of the lagoon liner.

2.5.4.3 Topography

A topographic GPS survey of the test hole locations and selected existing ground locations across the proposed lagoon site was completed on November 9, 2011 along with the geotechnical investigation. From the topographic survey data, the existing ground elevation at the proposed site was relatively flat with an average elevation of 335.3 m. The elevations varied across the site from 334.7 m to 335.8 m. The existing ground is sloped to the southwest of the existing WTS. A pond/wetland area was observed southeast of the existing WTS approximately 70 m northwest of the TransCanada Highway. A 20 m

diameter bedrock outcrop extending approximately 2.0 m above the surrounding ground with a peak elevation of 336.95 m was observed approximately 150 m southwest of the pond and approximately 60 m southeast of the proposed lagoon dikes. The location of the bedrock outcrop is shown on Plan 1 attached in Appendix B.

2.5.5 Population Contributing Effluent

JRCC was provided with average monthly truck-haul records for 2005 and overall yearly truck-haul records for 2006. According to Manitoba Conservation's Parks and Natural Areas Branch, more recent truck-haul quantities are not available.

The number of cottages and businesses in the Falcon Lake Park District (includes Falcon Lake and Barren Lake), the West Hawk Lake Park District (includes West Hawk, Caddy Lake, Star Lake, Hunt Lake, Florence Lake and Nora Lake) and all remote cottages and businesses were provided by the Manitoba Conservation Parks and Natural Areas Branch.

The organic and hydraulic loadings to the proposed truck-haul lagoon were calculated based on current and future scenarios. The current scenario is that a portion of the cottages and business are serviced by septic tanks and fields and a portion are serviced by holding tanks. Legislation is in place that requires all cottages and businesses to move from septic tanks with fields to holding tanks. It is assumed that by design year 20 (2031) all cottages and businesses will be serviced by holding tanks, with the exception of remote cottages on septic tanks and fields that will have septage hauled (barged then trucked for island cottages) to the proposed lagoon. Organic and hydraulic loadings for this scenario were also calculated. Current organic and hydraulic loadings were calculated based on the 2005 and 2006 truck-haul records, while future loadings are based upon the number of cottages and businesses utilizing holding tanks and some remote cottages on septic tanks and fields.

2.5.5.1 Cottage Population

The number of cottages and businesses in the Falcon Lake Park District and the West Hawk Lake Park District are as follows:

Table 2.2: Number of Cottages, Businesses and Non-Profits

Type	Falcon Lake Park District	West Hawk Lake Park District	Total
Road Accessible Cottages	584	769	1,353
Road Accessible Businesses and Non-profits	5	8	13
Remote Cottages	7	147	154

Type	Falcon Lake Park District	West Hawk Lake Park District	Total
Remote Businesses and Non-profits	2	0	2

Manitoba Conservation Parks and Natural Areas Branch indicated that approximately 105 of the road accessible cottages (7.8%) and five of the remote cottages (3.2%) are occupied year round. The remainder of the cottages are occupied seasonally. The occupancy rate of cottages deemed as seasonal will be 4 people/cottage and the occupancy rate for cottages deemed year round will be 2.5 people/cottage. Seasonal occupancy has been assumed at approximately 45 days/year during the period of May 1 to September 30, (153 summer days).

The percentage of cottages and businesses on holding tanks and the percentage on septic tanks and fields was calculated based on the full time and seasonal cottage and business populations and the total truck-haul volume from 2005. Based on the calculations currently 86.8% of cottages and businesses are serviced by septic tanks and fields and 13.2% are serviced by holding tanks.

Table 2.3: Breakdown of Road Accessible and Remote Cottages

Type	Full Time			Seasonal			Total
	Holding Tanks	Septic Tanks	Total	Holding Tanks	Septic Tanks	Total	
Road Accessible Cottages	14	91	105	165	1,084	1,249	1,353
Remote Cottages	0	5	5	0	149	149	154

The current equivalent population serviced by the proposed lagoon during the 153 days summer season would be 229 persons on holding tanks (35 year round and 194 seasonal) and 1,503 persons on septic tanks (228 year round and 1,275 seasonal).

In the future for road accessible areas, it is assumed that all loading will come from holding tanks for an equivalent population of 1,732. In addition, the equivalent population of 188 people from 154 remote cottages will have septage hauled to the proposed lagoon. Of the 188 equivalent people 175 are seasonal residents and 13 are full time residents.

More information is contained in Table 1, which is attached in Appendix C.

2.5.5.2 Business, Resorts and Non-profit Populations

The Parks and Natural Areas Branch was contacted regarding the nature of the businesses and non-profits in the Falcon Lake and West Hawk Park Districts. Most businesses and non-profits are small and can be assumed to have an equivalent occupancy of 1/3 person for the entire year (one person for eight hours a day) with the exception of four resorts. The Falcon Trails Resort has 12 cabins with a total occupancy of 61 people, Penguin Resort has 12 cabins with a total occupancy of 60 people, Caddy Lake Resort has nine cabins with a total occupancy of 56 people and the Green Bay Resort has one cabin with a two person occupancy. The Falcon Trails resort is open year round while the other three resorts are open seasonally. The Falcon Trails Resort was contacted for its average occupancy rates that were reported as 100% in July and August, 80% in May, June and September, 60% in April and October and 40% in November - February. The remaining resorts can be assumed to have 100% occupancy during July and August and 80% occupancy in May, June and November and 0% during the remaining months. The following table summarizes the resort and business populations.

Table 2.4: Business and Resort Populations and Occupancy Rates

Name	Number of Units	Maximum Occupancy	Average Occupancy During 153 day season	Average Occupancy During 212 day off season
Falcon Trails Resort	12	61	88%	48%
Penguin Resort	12	60	88%	0%
Caddy Lake Resort	9	56	88%	0%
Green Bay Resort	1	2	88%	0%
Remaining Businesses	9	9	33%	33%

The equivalent population during the 153 day summer season for the business population used for organic and hydraulic loadings calculations would be 161 people (54 + 53 + 49 + 2 + 3). Of the 161 equivalent people, currently 21 people are serviced by holding tanks and 140 people are serviced by septic tanks and fields. In future, all 161 equivalent people will be serviced by holding tanks. The equivalent population during the 212 day off season would

be 32 people (29 + 0 + 0 + 0 + 3). Of the 32 equivalent people, currently four people are serviced by holding tanks and 28 people are serviced by septic tanks and fields. In future all 32 equivalent people will be serviced by holding tanks.

In the future, the septage from two remote non-profits will be hauled to the lagoon, which will result in an extra equivalent population of 1 person (2 x 1/3) on a septic tank.

More information can be found in Table 1, attached in Appendix C.

2.5.5.3 Future Growth

According to Manitoba Conservation Parks and Natural Areas there is no growth expected in the cottage and business populations in the West Hawk and Falcon Lake Park Districts for the lifetime of the proposed lagoon.

2.5.5.4 Population Summary

There is a total equivalent road accessible cottage population of 1,732 people, of those approximately 263 are full time residents and 1,469 are seasonal. There are 175 seasonal residents and 13 full time residents from remote cottages that will have septage hauled to the proposed lagoon in future. There is an equivalent population of 161 people from the resorts and businesses during the summer season and an equivalent population of 32 people during the offseason. In the future, an equivalent population of 1 person from a remote business will have septage sent to the proposed lagoon.

2.5.6 Lagoon Loadings

The following table presents the reported truck-haul quantities from 2005 including the breakdown into septage and holding tank wastewater by JRCC's calculations.

Table 2.5: Reported truck-haul records for 2005 and JRCC breakdown into septage and holding tank wastewater

Month	Reported Values	JRCC Break-Down	
	Combined Truck-Haul Volume (m ³)	Truck-Haul Septage (m ³)	Truck-Haul Holding Tanks (m ³)
Jan	122.1	0	182.4
Feb	98.8	0	164.7
Mar	116.0	0	182.4
Apr	148.7	0	176.5
May	411.1	0	1,164.1

Month	Reported Values	JRCC Break-Down	
	Combined Truck-Haul Volume (m ³)	Truck-Haul Septage (m ³)	Truck-Haul Holding Tanks (m ³)
Jun	652.9	37.2	1,126.5
Jul	1,585.4	38.4	1,164.1
Aug	1,335.2	38.4	1,164.1
Sep	927.8	37.2	1,126.5
Oct	1,458.0	16.1	182.4
Nov	189.1	0	176.5
Dec	94.9	0	182.4
SUBTOTAL	7,139.9	167.4	6,992.4
TOTAL	7,139.9	7,159.8	

The septage and holding tank wastewater breakdown by JRCC is based on actual cottage and business numbers, a septage production of 200 L/person/year and a wastewater production of 150 L/person/day. Note the breakdown by JRCC assumes that the total summer loadings from holding tanks are averaged over the time period from May 1 to September 31 and the total winter loadings from holding tanks are averaged over the time period from October 1 to April 30. The total yearly loadings from septic tanks are averaged over the allowable discharge period of June 1 to October 15. Calculations are explained in the following section. Please see Table 1, attached in Appendix C, for more information.

2.5.6.1 Current Organic Loadings

To calculate the organic loading to the lagoon, the quantity of organic material measured as the five day Biochemical Oxygen Demand (BOD₅) in the incoming wastewater must be calculated. A loading of 0.076 kg BOD₅/person/day is typical for piped wastewater or wastewater from a holding tank. The Ontario Ministry of the Environment (MOE) Design Guidelines for Sewage Works (2008) were reviewed to determine the average BOD₅ concentration of septage. The guidelines state an average BOD₅ concentration in septage of 6,500 mg/L and a suggested design value of 7,000 mg/L. The *United States Environmental Protection Agency Guide to Septage Treatment and Disposal (1994)* was also reviewed. The guide states an average BOD₅ concentration in septage of 6,480 mg/L which is consistent with the MOE guidelines. Therefore, the organic loading from septic tank pump outs will be based on a BOD₅ loading rate of 7,000 mg/L. The typical per capita septage production rate of 200 L/year will be utilized for all populations on septic tanks.

Based on the current populations on holding tanks and septic tanks the organic loading produced would be 36.1 kg BOD₅/day (19.0 kg BOD₅/day from holding tanks and 17.0 kg BOD₅/day from septic tanks).

2.5.6.2 Future Organic Loadings

In the future, all cottage and business populations for road accessible areas will be on holding tanks as described previously and all remote cottages and businesses will have septage hauled to the proposed lagoon.

Therefore, based on the future cottage and business populations on holding tanks and remote cottages and businesses on septic tanks the future organic loading would be 145.9 kg BOD₅/day (143.9 kg BOD₅/day from holding tanks and 2.0 kg BOD₅/day from septic tanks).

2.5.6.3 Organic Loading Summary

The lagoon will be designed to handle the future organic loadings based on all road accessible cottage and business populations on holding tanks, including remote cottages and businesses utilizing septic tanks. The design organic loadings will be approximately four times greater in future compared with the current loadings (145.9 kg BOD₅/day in future and 36.1 kg BOD₅/day currently). This will result in the primary cell being sized four times larger than required for the current loadings. More information can be found in Table 1 which is attached in Appendix C.

2.5.6.4 Current Hydraulic Loadings

The current hydraulic loadings to the proposed lagoon were based on the calculated cottage and business populations described above with typical holding tank wastewater production rates. Current hydraulic loadings were confirmed by the truck-haul records from 2005 and 2006.

A typical water usage for populations on piped systems is approximately 300 L/person/day. Based on past experience it is known that populations on holding tanks tend to conserve water. The U.S. Environmental Protection Agency Onsite Wastewater Treatment Systems Manual lists a typical wastewater production of 150 L/person/day for cabins and resorts. This value will be used for design. A typical per capita septage production rate of 200 L/year will be utilized for all populations on septic tanks.

Based on truck-haul records provided by Manitoba Conservation, the total volume hauled to the lagoon in 2005 was 7,140 m³. The total truck-haul

volume for 2006 was also provided by Manitoba Conservation as 5,350 m³. The larger value from 2005 will be used to confirm current hydraulic loadings.

The current hydraulic loading to the proposed lagoon was calculated based on 13.2% of cottages and businesses currently on holding tanks and 86.8% of cottages and businesses on septic tanks and fields. This results in an average hydraulic loading of 37.6 m³/day during the 153 day summer season, 5.9 m³/day during the 212 day off season and a total septic tank hydraulic loading of 137.7 m³ during the summer season and 29.7 m³ during the off season. Therefore, the total yearly hydraulic loading would be 7,160 m³/year. This value is within 0.3% of the 2005 truck-haul quantity of 7,140 m³/year, and is therefore deemed reasonable.

2.5.6.5 Future Hydraulic Loadings

Future hydraulic loadings to the lagoon were calculated based on all road accessible cottage and business populations serviced by holding tanks including the remote cottages and businesses utilizing septic tanks. The wastewater production rate of 150 L/person/day and septage production rate of 200 L/person/year will be applied to future populations.

The future hydraulic loading to the lagoon will be 284.0 m³/day during the 153 day summer season, 44.3 m³/day during the 212 day off season and a total septic tank hydraulic loading of 15.8 m³ during the summer season and 1.5 m³ during the off season. Therefore, the total yearly hydraulic loading to the proposed lagoon would be 52,852 m³/year.

2.5.6.6 Hydraulic Loading Summary

The lagoon will be designed to handle the future hydraulic loadings based on all road accessible cottage and business populations on holding tanks, including remote cottages and businesses utilizing septic tanks. The hydraulic loadings will be approximately 7.4 times greater in future compared with the current loadings (52,854 m³ in future and 7,160 m³ currently). More information can be found in Table 1, which is attached in Appendix C.

2.5.7 Lagoon Size Requirements

An Environment Act Licence is required from Manitoba Conservation for the construction and operation of a new lagoon. Any new lagoon licence will require a minimum hydraulic storage period of 230 days (November 1 to June 14).

The lagoon would be constructed with one primary cell and one secondary cell each with 4:1 inner and outer side slopes. The secondary cell discharge pipe would be located 0.3 m above the cell floor elevation.

The lagoon will be sized to handle the future organic and hydraulic loadings based on all cottage and business populations on holding tanks, with the exception of remote cottages and businesses on septic tanks.

2.5.7.1 Primary Cell

The minimum sizing of the primary cell is based on the required surface area at a 0.75 m height from the cell floor and the standard organic treatment rate for a facultative lagoon of 56 kg BOD₅/ha/day. The required surface area at 0.75 m to treat the future loadings of 145.9 kg/day would be 26,046 m² (145.9/56 x 10,000).

The primary cell flat bottom area would be 150 m x 161 m and designed with a maximum liquid level of 1.5 m and a freeboard of 1.0 m, as per Manitoba Conservation requirements.

2.5.7.2 Secondary Cell

The required hydraulic storage during the 230 day winter period from November 1 to June 14 for the future loadings would be approximately 21,075 m³. The future hydraulic loadings to the lagoon during the 135 day summer period from June 15th to October 31st would be approximately 31,778 m³ for a total yearly loading to the lagoon of 52,852 m³. The storage capacity of a facultative lagoon is calculated by the combined volume of the “top half” of the primary cell (liquid storage from 0.75 m depth to 1.5 m depth) and the volume of the secondary cell from the discharge pipe invert elevation to the maximum liquid level. The top half of the primary cell would provide a hydraulic storage of approximately 20,275 m³. Therefore, to accommodate the 230 day winter storage period the secondary cell is only required to store 800 m³ of effluent (21,075 – 20,275). If the secondary cell was designed to only store the minimum requirement of 800 m³ of effluent, the lagoon would require 66 discharges over the course of the 135 day summer period.

The secondary cell of the lagoon will be sized appropriately to allow three discharges per year at peak design loading, for ease of operation. During operation of the lagoon at peak design loading, the intercell valve would be opened after fall discharge of the lagoon and allowed to fill up from winter and spring loadings. Prior to June 15, the intercell valve would be closed and the secondary cell effluent would be tested for the discharge criteria. If the test

results are acceptable, the secondary cell volume from the discharge pipe invert elevation to the liquid level would be discharged starting on June 15. Once the secondary cell is fully discharged, the inter cell valve could be opened and the lagoon cells would be allowed to equalize. The intercell valve would remain open and both lagoon cells would be allowed to fill up from summer hydraulic loadings. When both cells reach a liquid level of approximately 1.35 m from the cell floor, the intercell valve would be closed and the secondary cell effluent would be tested for the discharge criteria. If test results are acceptable, the secondary cell could be discharged while the primary cell would accept hydraulic loadings to the lagoon during the discharge period. After discharge of the secondary cell, the intercell valve could then be re-opened, the cells would be allowed to equalize and both lagoon cells would again be allowed to fill up. Prior to the end of the discharge period, the intercell valve would be closed, the secondary cell effluent tested and discharged before October 31. The intercell valve would then be re-opened, both lagoon cells would be allowed to equalize and the lagoon would be allowed to fill up over the winter storage period. This discharge procedure would be repeated each year.

To fully discharge one year of peak design hydraulic loadings over three discharges during the summer discharge period the secondary cell must be sized to accommodate a maximum volume of 21,174 m³ from the discharge pipe elevation to the maximum liquid level. Therefore the total lagoon hydraulic storage would be 41,449 m³ (20,275 m³ from the primary cell + 21,174 m³ from the secondary cell). The lagoon would be able to accommodate 78% of the yearly peak hydraulic loading of 52,853 m³.

The secondary cell would have a flat bottom area of approximately 150 m x 105 m and will be designed with a freeboard of 1 m above the maximum liquid level, as per Manitoba Conservation requirements.

2.5.8 Lagoon Regulatory Requirements

2.5.8.1 Province of Manitoba Design Objectives

The Province of Manitoba Design Objectives for Standard Sewage Lagoons was used as a guideline in the layout and design of the lagoon.

Organic Loading

Although a lagoon operates at various organic efficiencies throughout the year an average organic treatment capacity of 56 kg BOD₅/ha/day at 0.75 m depth in the primary cell has been utilized for design purposes.

Hydraulic Loading

The lagoon cannot be discharged between November 1 and June 15 (230 day winter storage period) as per current guidelines. Therefore, the lagoon must have the storage capacity for this time period based upon half the volume of the primary cell and the secondary cell volume from the invert of the discharge pipe (0.3 m) to the maximum liquid level (1.5 m).

Lagoon Liner

Sewage lagoons are to be designed and constructed such that the interior surface of the proposed lagoon is underlain by at least one metre of soil having a hydraulic conductivity of 1×10^{-7} cm/sec or less. In the absence of soils with a hydraulic conductivity of 1×10^{-7} cm/sec or less, the interior surfaces of a lagoon could be lined with a synthetic liner. In areas sensitive to groundwater contamination, a flexible synthetic liner may be recommended.

2.5.8.2 Nutrient Management Plan

New nutrient reduction guidelines were released in the *Manitoba Water Quality Standards, Objectives, and Guidelines, November 28, 2011*. The regulations include province wide standards for phosphorus reduction and where site-specific conditions warrant, nitrogen reduction. Under the new nutrient standards, a 1.0 mg/L phosphorus limit immediately applies for all new, expanding or modified wastewater treatment facilities. The exception being small wastewater treatment facilities that serve less than 2,000 equivalent people which have the option of implementing a nutrient reduction strategy instead of the 1.0 mg/L phosphorus limit. Nutrient reduction strategies include, but are not limited to, effluent irrigation, trickle discharge or constructed wetlands.

Nitrogen reduction to 15 mg/L is required on a site-specific basis depending on the receiving environment for new and expanding wastewater treatment facilities serving more than 10,000 equivalent people. The document also set the discharge requirements for fecal coliform at 200 organisms/100 mL sample, Total Suspended Solids at 25 mg/L and the Biochemical Oxygen Demand at 25 mg/L (facilities with ammonia or total nitrogen limits have a Carbonaceous Biochemical Oxygen Demand limit of 25 mg/L).

The proposed lagoon has an organic treatment capacity of 145.9 kg BOD₅/day, which is equivalent to 1,893 residents on holding tanks and 188 residents on septic tanks. This equivalent population is just over the 2,000 person limit and therefore it is expected Manitoba Conservation will require the phosphorus reduction guideline of 1.0 mg/L or less be met.

Based upon the new guidelines, the following options were considered to address nutrient management, with particular emphasis on phosphorus reduction for the South Whiteshell truck-haul lagoon.

Phosphorus Reduction by Filtration

Sewage treatment plant technology, such as chemical addition and filtration systems could be utilized to reduce the phosphorus concentration in the lagoon. The effluent could be pumped from the primary cells to a filtration building and filtered through a continuous backwash sand filter or a cloth disk filter. A chemical flocculent such as alum would have to be added to the wastewater prior to filtration. Backwash containing the phosphorus would be sent back to the primary cell where it settles out into sludge. The sludge can accumulate in the lagoon for approximately 20 - 25 years and then will have to be removed.

This level of treatment is costly as equipment and housing is required as well as annual operating costs and chemical costs. An electrical power source is also required, such as a hydro line to the lagoon. It is not a preferred option for the South Whiteshell truck-haul lagoon due to the higher capital cost and operating and maintenance costs.

Phosphorus Reduction by Surface Chemical Treatment

This option involves application of chemicals such as alum to wastewater in the secondary cell to reduce the level of phosphorus in the treated effluent, if prior to discharge the phosphorus concentration in the wastewater is found to be greater than 1.0 mg/L. The alum is broadcast onto the surface of the secondary cell utilizing a gas driven pump and spray system from the top of the dike, or from a boat on the surface of the secondary cell. The alum creates flocculation of the turbidity and phosphorus which results in settlement to the bottom. The effluent can then be discharged from the secondary cell with a reduced level of phosphorus. This option could possibly be used for the South Whiteshell truck-haul lagoon to obtain a phosphorus upper limit of 1.0 mg/L. The phosphorus level in the treated effluent must be tested prior to discharge and if the phosphorous is not at or below 1.0 mg/L, spreading of the alum on the second cell surface may have to be repeated.

Constructed Wetlands

Constructed wetlands are used to polish treated effluent from a lagoon, and have the potential to provide nutrient reduction. However, they can require large land areas for construction, have increased odour potential, can favour

mosquito breeding (due to vegetation type, very shallow effluent and minimal wind action) and add cost to the project. In addition, the use of constructed/engineered wetlands requires further investigation regarding their effectiveness under climatic conditions in Manitoba.

Rough sizing calculations for an engineered wetlands for the South Whiteshell truck-haul lagoon would require a land area of approximately 5.5 ha. This land area is almost equal to the land area required for the lagoon. The added costs of the constructed wetlands and the uncertain effectiveness, as well as the other disadvantages cause this option to become not feasible.

Trickle Discharge and Natural Wetlands

Trickle discharge as a nutrient reduction strategy will allow nutrients to enter the soils along the discharge route and allow nutrient uptake by plants along the drainage route as a means of reducing the phosphorus concentration in the treated effluent. The expected discharge route from the proposed lagoon is through approximately 800 m of ditch and 430 m (straight line distance) of natural wetlands before entering the Talbot Lake. The effluent then flows approximately 800 m through a defined drainage ditch and approximately 5,000 m (straight line distance) through the Whiteshell Bog natural wetlands which is graded to a first order drain which enters the Boggy River. In total the drainage route to the Boggy River is approximately 7,030 m of ditches and natural wetlands. The maximum discharge volume from the lagoon will be approximately 21,175 m³ (the total storage volume in the secondary cell). If the entire volume was discharged over a one month period, the discharge rate would be approximately 8.2 L/s (130 gal/min). Based on the low discharge rate from the lagoon and the long discharge route through natural wetlands it is expected that natural uptake of nutrients by the plants and soils will occur.

Recommended Option

The recommendation for the South Whiteshell truck-haul lagoon to meet the 1.0 mg/L phosphorous limit of a new Environmental Licence, would be to broadcast alum in the secondary cell to capture phosphorus and reduce levels in the treated effluent if prior to discharge the phosphorus concentration in the wastewater is found to be greater than 1.0 mg/L. Trickle discharge and the natural wetlands along the drainage route would also be utilized to provide additional nutrient uptake by the plants and soils of the natural wetlands. This solution is both cost effective and requires less operation than the other options, as spreading of the alum would only need to occur prior to discharge, if the phosphorus concentration is above 1.0 mg/L.

2.5.9 Summarized Selected Design Criteria

The following selected criteria would be used for design purposes:

- A total equivalent design population of 1,893 people on holding tanks and 188 people on septic tanks during the peak 153 day season from May 1 to September 30
- A total equivalent design population of 295 people on holding tanks and 13 people on septic tanks during the 212 day off season from October 1 to April 30
- A total daily organic loading of 145.9 kg BOD₅/day
- Primary cell with surface area of 26,275 m² at 0.75 m height from the floor, providing a daily organic treatment capacity of 145.9 kg BOD₅/day and a hydraulic storage volume in the top half of 20,275 m³
- A yearly hydraulic loading to the lagoon of 52,852 m³
- A total hydraulic storage capacity in the secondary cell above the invert elevation of 21,175 m³
- A total hydraulic capacity of the lagoon of 41,450 m³, which allows for three discharges per year at the projected year 20 lagoon loadings
- The discharge pipe invert to be at 0.3 m above the cell floor level of the secondary cell
- Discharge from the lagoon is expected to follow local drainage routes through natural wetlands southwest from the lagoon location, across the TransCanada highway through culverts, and south through wetlands to the Boggy River
- The horizontal liner will be constructed with a minimum 1.0 m thick re-worked clay liner
- A 3.0 m wide vertical cut-off wall constructed with re-worked clay soils will extend a minimum of 1.0 m into the horizontal clay liner and extend to the top of dike elevation
- A 4:1 slope will be used for the inner and outside dikes of the cells
- An access road around the existing WTS, truck turnaround and a spillway for trucked effluent would be provided in the primary cell
- A 1.8 m high fixed-knot game fence with lockable gate would be installed around the perimeter of the lagoon
- Rip rap will be installed on the inside dikes of the lagoon at an elevation 0.5 m above and 0.5 m below the high water level of the lagoon cells (not shown on the plans) and rip rap will be installed at the inlet and outlet of the intercell pipe, and the outlet of the discharge pipe

- Construction of perimeter ditches and discharge ditch
- Site markers, warning signs, and valve markers will be installed.

2.5.10 Lagoon Layout

The lagoon would consist of a primary cell to the northeast and a secondary cell to the southwest. The proposed lagoon layout is shown on Plan 1 in Appendix D. A legal survey is required to determine the exact locations of the park boundary, TransCanada pipeline R.O.W. and the TransCanada Highway R.O.W. The layout of the cells may be altered upon completion of the legal survey to better fit the available land.

2.5.11 Lagoon Construction Detail

2.5.11.1 General, Conceptual Liner Design and Construction Techniques

Conceptual plans (Plans 1 to 5) for the new lagoon are provided in Appendix D.

Prior to construction of the new lagoon, the lagoon construction area plus a 30 m buffer zone, the access road R.O.W. and the discharge ditch area would be cleared and grubbed. The topsoil from the lagoon area would be removed and stockpiled. Approximately 50% of the outside of the dike is permitted to be constructed with topsoil. The topsoil will also be used as dressing on the dikes and perimeter ditches. The new lagoon would be excavated to the cell floor elevation. The clay soils from 1.0 m below the cell floor elevation would be excavated and re-worked and re-compacted with a sheepsfoot roller to 95% Standard Proctor Density on a maximum 150 mm (6 in) compacted lift. A limited range of moisture content will be permitted. The material shall not be so wet nor so dry that compaction equipment cannot compact the fill into a homogeneous mass. Material too wet shall be dried or wasted and material too dry shall be wetted.

The vertical cut-off walls will be constructed with excavated clay soils from the cell area or from a borrow pit. The cut-off wall will extend from the top of dike elevation to an at least 1.0 m below the cell floor elevation. The vertical cut-off wall will be construction with similar construction techniques as the horizontal liner, as described above.

The new lagoon cell floor bottom will be 2.5 m lower than the top of dike. The inner and outer dike slopes would be constructed at 4:1 slope. A discharge pipe will be installed in the new secondary cell 0.3 m above the cell floor elevation. Rip rap would be installed at the intercell and discharge piping locations to reduce erosion. Silt fencing would be placed around the lagoon construction area at locations which are thought to drain from the site. Perimeter ditches

would be constructed surrounding the entire lagoon. Upon completion of construction, the excess topsoil that was stripped off the new cell area would be placed on the outside of the dikes and the area would be seeded. A fixed-knot game fence surrounding the new lagoon would be constructed with a lockable access gate.

2.5.11.2 Construction Details

All topsoil would be removed to a depth of approximately 500 - 600 mm from the entire cell floor as well as the dike areas.

Construction of lagoon liner (cell bottom and cut-off walls) should be in accordance with the following specifications:

1. The liner shall be constructed of clay.
2. The liner shall be at least one metre in thickness.
3. The liner shall have a hydraulic conductivity of 1×10^{-7} cm/sec or less at all locations.

Specifications should indicate the foundation be scarified to a depth of 150 mm (6 in.) and compacted with a minimum of eight passes of a sheepsfoot roller prior to placement of the compacted embankment material and liner material. Complete foundation preparation should be approved by the Engineer before any embankment or liner material is placed. Embankment (both common topsoil and relatively impermeable soil) and liner material (medium plastic clay soil), should be compacted with a minimum of eight passes of a sheepsfoot roller on a 150 mm (6 in.) compacted lift. The lagoon bottom will be graded to a tolerance of ± 50 mm (2 in).

The lagoon construction specifications should indicate that the sheepsfoot roller shall have a minimum foot pressure of no less than 1,700 kPa (250 psi). The drum diameter of the sheepsfoot roller should not be less than 1,200 mm (4 ft.). Each roller should be equipped with cleaning fingers designed to prevent the accumulation of material between the tamping feet. The foot pressure would be calculated by taking the total mass of the roller and dividing it by the greater of: the area of the maximum number of tamping feet in one row parallel to the axis of the roller, or by 5 percent of the total foot area. The roller foot should be at least 200 mm (8 in.) long and should have a minimum foot area of at least 4,500 mm² (7 sq. in.).

A limited range of moisture content should be permitted. The material shall not be so wet nor so dry that compaction equipment cannot compact the fill into a

homogeneous mass. Material too wet shall be dried or wasted as directed by the Engineer and material too dry shall be wetted as directed by the Engineer. All constructed earthen lagoon components shall be graded to a tolerance of ± 50 mm (2 in.).

The specifications should state that the dikes and embankment are to be seeded with a grass such as brome.

The outer slope and perimeter drainage system would prevent surface drainage from entering into the lagoon and the ponding of surface drainage around the perimeter of the lagoon.

2.5.12 Lagoon Maintenance

Maintenance of the lagoon will include:

- Maintaining the fencing, gate and lock
- Ensuring the gate is locked at all times and only the local septic haulers and Parks department staff have access to the site
- Maintaining the intercell and discharge piping and valves
- Maintaining grass cover on dikes to a height of no more than 0.3 m in height
- Maintain a program to prevent and remove burrowing animals
- Maintain including snow clearing of the access road and truck turnaround area.

3.0 POTENTIAL ENVIRONMENTAL IMPACTS

3.1 Releases to Air, Water, Land

3.1.1 Air

In general, nuisance odours only occur in facultative lagoons that are improperly sized and organically overloaded. Odours are also generated under anaerobic conditions. In the summer the lagoon would be aerobic at the surface, facultative at the centre and anaerobic at the bottom. Minimal to no treatment would occur in the winter and with ice cover, the treatment process would predominantly be anaerobic. Therefore, the lagoon may generate some odours for a short time each spring during the thawing or turn-over period when the lagoon changes from an anaerobic process to an aerobic process.

The proposed new lagoon is located over 2.75 km from the nearest residence and community center (Falcon Lake). Prevailing winds from the northwest are not expected to cause odours to drift toward the nearest resident or the community.

Environmental management practices to mitigate the above potential impacts to the air are provided in Section 4.1 of this report.

3.1.2 Water

Pollutants that may be released into the water during the operation of the lagoon include coliforms, organic wastes, suspended solids, and other materials that are disposed by truck-haul into the new lagoon.

Pollutants that may be released into the water during the lagoon construction activities include petroleum hydrocarbons (PHCs) and sediments due to soil erosion.

Surface water may be impacted if the wastewater is not sufficiently treated and then subsequently discharged from the lagoon. Effluent discharged from the lagoon would eventually reach the Boggy River.

Groundwater may be impacted if wastewater leaks/seeps through the lagoon liner and into the groundwater below.

Environmental management practices to mitigate the above potential impacts to the water are provided in Section 4.2 of this report.

3.1.3 Land

The land would be significantly altered by clearing of the bush and construction of the lagoon dikes. An access road would be constructed to the lagoon, and fencing would be installed around the perimeter of the lagoon.

The new lagoon liner is proposed to be constructed with re-worked and re-compacted clay to a hydraulic conductivity of less than 1×10^{-7} cm/sec, seepage to the surrounding land is expected to be negligible.

Pollutants that may be released to the land are predominantly petroleum hydrocarbons (PHCs), which could be released during construction activities. Equipment leaks or re-fuelling incidences could result in an impact to the land as a result of construction activities.

Environmental management practices to mitigate the above potential impacts to the land are provided in Section 4.3 of this report.

3.2 Wildlife

The proposed lagoon site is located in the Lake of the Woods ecoregion of Canada. Characteristic wildlife includes moose, black bear, wolf, lynx, snowshoe hare, and woodchuck. Bird species include ruffed grouse, hooded merganser, pileated woodpecker, bald eagle, turkey vulture, herring gull, and waterfowl.

The Manitoba Conservation Data Centre was contacted regarding the proposed lagoon project and has indicated that there were no occurrences of rare species at the lagoon site in their database. Refer to the Manitoba Conservation Wildlife and Ecosystem Branch, January 30, 2012 correspondence, attached in Appendix C.

Impacts to wildlife and wildlife habitat are possible, however not expected, as the lagoon is to be located next to a WTS which has been previously disturbed. The area to be cleared is small compared to the surrounding forested area of the Whiteshell Provincial Park.

3.3 Fisheries

Impacts to fish along the discharge route are unlikely as the lagoon effluent would be discharged after fish spawning has normally occurred and only when the treated effluent meets current Manitoba Conservation guidelines. Impacts to fish in the Boggy River are not expected since the treated effluent discharged in the above manner is expected to travel for at least 6.5 kilometres of ditches and wetland/marshes before emptying into the River. The expected discharge route is shown on Plan 2 attached in Appendix D.

The Boggy River provides year round habitat for a diverse assemblage of fish species including two species of special concern: northern brook lamprey and carmine shiner. Other species identified in the Fisheries Inventory and Habitat Classification System (FIHCS) are: northern pike, shorthead redhorse, walleye, white sucker, central mudminnow, pearl dace, mimic shiner, finescale dace, fathead minnow, Johnny darter, brook stickleback, rock bass, blackside darter, common shiner, hornyhead chub, spottail shiner, longnose dace and iowa darter. It is also noted in the FIHCS that Boggy River was rated as a waterbody with only slight limitations to fish production.

The Fisheries Science and Fish Culture Section, Fisheries Branch of Manitoba Conservation and Water Stewardship was contacted regarding the proposed lagoon discharge route. Conservation and Water Stewardship has indicated that their concern with the proposed lagoon would be any potential for the effluent to degrade water quality in Boggy River. They also state that given the effluent should meet or exceed Manitoba Water Quality Standards, Objectives and Guidelines prior to discharge, there is quite a distance the effluent will travel before reaching Boggy River and the route is through areas of bog and wetlands, there should be minimal effects from the effluent. Refer to the Manitoba Water Stewardship February 13, 2012 correspondence, attached in Appendix C.

As described in Section 4.2, effluent would be sampled and analyzed prior to discharge. If the effluent does not meet the license requirements for discharge, it would not be discharged.

3.4 Surface Water and Groundwater

Surface Water

Impacts to surface water due to discharge of the lagoon are not expected as the treated effluent will not be discharged unless Manitoba Conservation discharge criteria are met. The discharge from the lagoon should not cause or contribute to flooding in or along the drainage route. The lagoon would not be discharged during flood conditions. There is no potential to impact the navigation of surface waters as a result of the lagoon project, as the proposed drainage route is not in the immediate vicinity of a navigable body of water.

Groundwater

No impacts to groundwater are expected as the lagoon would be lined in accordance with Manitoba Conservation guidelines.

3.5 Forestry

The lagoon construction area and access road area would require clearing and grubbing, and it may be possible for the Parks Branch to salvage timber for processing. There would be minimal impact to forestry as the Park does not permit commercial forestry activities.

3.6 Vegetation

Characteristic vegetation in the “Lake of the Woods” ecoregion includes a succession from trembling aspen, paper birch, and jack pine to white spruce, black spruce, and balsam fir. Warmer portions of the ecoregion support red and eastern white pine. Cooler and wetter sites support black spruce and tamarack.

Manitoba Conservation Wildlife and Ecosystem Protection Branch was contacted regarding occurrences of rare or endangered species in their database at the proposed new lagoon site. The Branch identified that there were no occurrences of rare species at the lagoon expansion site. Refer to Manitoba Conservation Wildlife and Ecosystem Protection Branch correspondence dated January 30, 2012, attached in Appendix C.

3.7 Heritage Resources

The Manitoba Historic Resources Branch was contacted regarding the proposed site. The Historic Resources Branch indicated that the potential to impact significant heritage resources is low and that they have no concerns with the project. Refer to the Manitoba Historic Resources Branch February 6, 2012 memorandum, attached in Appendix C.

3.8 Socio-Economic Implications

The lagoon expansion is not expected to have adverse socio-economic impacts. In fact, construction related economic activity would have a positive economic impact.

4.0 MANAGEMENT PRACTICE

4.1 Mitigation of Impacts to Air

Although the lagoon would likely generate some odours for a short time each spring, during the thawing or turn-over period, prevailing (i.e. north-westerly) winds should not cause odours to drift toward the nearest residence, which is located at approximately 2.75 km northeast. Manitoba Conservation requires a minimum distance of 300 m from the nearest residence and 460 m from the nearest center of population.

Emissions from construction equipment and transport vehicles will be controlled through regular maintenance, and will meet all Provincial and local standards. Dust suppression methods (i.e. water spraying) will be utilized at the construction site if dry conditions create excessive dust through construction activities and transport, which becomes a nuisance to nearby residents. Due to the setback distance, it is unlikely that dust will have any impact on the community or to nearby residents.

4.2 Mitigation of Impacts to Water

4.2.1 Surface Water

Impacts to surface water or public health, due to discharge of treated effluent from the lagoon, are not expected, as the lagoon effluent would not be discharged unless it is in accordance with the following Manitoba Conservation guidelines:

1. The organic content of the effluent, as indicated by the five day biochemical oxygen demand would not be greater than 25 milligrams per litre
2. The total dissolved solids would not be greater than 25 milligrams per litre
3. The fecal coliform content of the effluent, as indicated by the MPN index would not be greater than 200 per 100 millilitres of sample
4. The total coliform content of the effluent, as indicated by the MPN index would not be greater than 1,500 per 100 millilitres of sample.

The above criteria are the effluent discharge requirements for municipal wastewater treatment lagoon as outlined by Manitoba Conservation in current lagoon licences.

Impacts to surface water due to discharge of the lagoon are not expected. Discharge events would consist of a maximum volume of approximately 21,175 m³ (available total storage in the secondary cell) being discharged over a one month period. Maximum discharge flow rates would be approximately 8.2 L/second (130 gal/min). The lagoon would not be discharged during flood conditions. Flooding of the lagoon would be unlikely as there are no significant bodies of water in the vicinity of the lagoon.

Cumulative effects of the treated effluent discharge on the receiving water bodies are not expected, as the treated effluent is expected to flow through at least 6.5 kilometres of wetlands/bogs before entering the Boggy River.

Specifications should state that any excess excavated material would be disposed on land above high water mark to prevent re-entry of the material into any water course. The stockpiles should be either covered with biodegradable mats or tarps or seeded with grass. Rip rap would be installed using clean rock (free of fine materials) to prevent the release of sediment from soil erosion into the discharge ditch. The construction specifications should also state that the release of sediments into the surrounding wetlands, during construction of the lagoon must be mitigated by trapping with silt fences. Silt fence installation details are shown on Plan 5 attached in Appendix D.

There would be no impacts to navigation as a result of the lagoon project, as the discharge route is not a navigable body of water.

4.2.2 Groundwater

Seepage of effluent from the lagoon is unlikely to affect groundwater as the lagoon would be lined with re-worked and re-compacted clay liner, which will have a hydraulic conductivity of less than 1×10^{-7} cm/sec as required by Manitoba Conservation guidelines.

At such time that the construction specifications are prepared, it is advised that the specifications outline to the contractor the requirements for handling and storage of fuels and hazardous materials during construction, as per Federal and Provincial regulations. The specification should state wording similar to the following:

- Diesel or gasoline should be stored in double walled tanks or have containment dikes around fuel containers for volumes greater than 68.2 L (15 gallons) or in compliance with provincial regulations
- Clean up material should be available at the site, consisting of a minimum of 25 kg of suitable commercial sorbent, 30 m² of 6 mil PVC, and an empty fuel barrel for spill collection and disposal

- Fuel storage and hazardous material areas established for project construction should be located a minimum of 100 m from a water body, and comply with provincial regulations
- Waste hazardous materials from construction activity and equipment must be properly collected and disposed in compliance with provincial regulation
- In the event of spills or leaks of fuels and hazardous materials, the contractor or operator should notify the project engineer and Provincial Authorities
- Hazardous material handling and storage would follow all provincial and federal regulations including WHMIS and spill containment requirements.

The specifications should also state that when working near water with construction equipment:

- Construction equipment is to be properly maintained to prevent leaks and spills of fuels, lubricants, hydraulic fluids or coolants
- There can be no re-fuelling or servicing of construction equipment within 100 m any water body.

4.3 Mitigation of Impacts to Land

As the lagoon would be lined with a re-worked and re-compacted clay liner, seepage to the surrounding land is expected to be negligible.

To minimize the potential for the release of Petroleum Hydrocarbon (PHC) pollutants into the soil, measures as identified in Section 4.2 should be incorporated into the tender specification document. These measures would outline fuel-handling procedures and require the contractor to have spill clean-up equipment on hand at the work site.

To minimize the potential for slope erosion, the outside slopes of the dikes would be constructed with a 4:1 slope and the dike tops and outside slopes would be seeded with grass. The discharge outlet location would be rip rapped to eliminate soil erosion into the ditch during discharge.

5.0 RESIDUAL EFFECTS

No negative residual effects are anticipated through the construction and operation of the lagoon expansion, due to the mitigation measures described above. Positive residual effects are possible from the properly sized wastewater treatment system that will allow the existing Falcon Lake lagoon to operate more efficiently due to the decreased loadings.

6.0 MONITORING AND FOLLOW-UP

Monitoring of the lagoon operation is to be conducted by a trained lagoon operator, who is to ensure liquid levels of the cells do not exceed the maximum allowable levels under the environmental licence. The operator is also to conduct sampling of lagoon effluent prior to discharge, and is to ensure water quality guidelines as described in the Environmental Licence are met. The construction contractor is to ensure that grass growth occurs on slopes and disturbed areas, after the construction activities are completed.

7.0 RESULTS OF PUBLIC CONSULTATIONS

Results of any public consultations undertaken or to be undertaken in conjunction with project planning:

Two public open houses were held to discuss the proposed lagoon construction project. The first public open house was held on August 15 at the Canad Inns Transcona in Winnipeg, Manitoba. The second open house was held on August 18 at the Whiteshell Community Club in Falcon Lake, Manitoba. The open houses were advertised in the Steinbach Carillon, Winnipeg River Echo, Dawson Trail Dispatch and the Winnipeg Free Press.

Poster boards were created and displayed at the open houses and were also available online. Members of Manitoba Conservation and Water Stewardship Parks Branch and representatives from JRCC were present at the open houses to answer questions and listen to comments from the public. Comment sheets were available at the open houses and were also available to be submitted online. The comment period was open from August 15 to September 30, 2012.

In total seven comment sheets were submitted. When asked if you were satisfied with the proposal five people responded yes, one responded not completely and one responded no. A summary of the generalized comments are as follows:

- Concerns with the nutrient loading reaching Lake Winnipeg
- Concerns with increased traffic to and from the site
- Concerns with who will pay for the lagoon
- Concerns with the location of the site not being central to the service area.

The above comments were addressed at the open house and are addressed in this EAP document. Comment sheets have been retained on file by JRCC.

8.0 SCHEDULE

8.1 Commencement Dates

Schedule for stages of the development, including proposed dates for planning, design, construction, commissioning, operation, and decommissioning and/or termination of operation (if known):

Lagoon design is proposed to begin upon receipt of an environmental licence. Lagoon construction is proposed to begin in the spring/summer of 2013, upon approval of funding. Commissioning and operation of the lagoon is proposed to begin upon completion of construction and after approval for use is obtained from Manitoba Conservation. No date of decommission has been set for the lagoon.

8.2 Environmental Approval Date

The proponent would like to complete the requirements of the Environment Act Proposal as soon as possible so that the lagoon construction can begin by the time specified above.

J. R. Cousin Consultants Ltd. requests that a draft copy of the licence be forwarded for review prior to the issue of the final licence.

9.0 FUNDING

Funding, including the name and address of any government agency or program (federal, provincial or otherwise) from which a grant or loan of capital funds have been requested (where applicable):

Funding for this project is from budgets created by Manitoba Conservation and Water Stewardship and Parks and Natural Areas Branch.

APPENDICES

Appendix A

Crown Lands and Property Agency - Lands Branch, February 1, 2012 E-mail Correspondence

Appendix B

Geotechnical and Topographic Investigation for the South Whiteshell Truck-Haul Lagoon

Appendix C

Table 1: Population, Hydraulic and Organic Loading Projections for the South Whiteshell Truck-Haul Lagoon

Water Stewardship, January 31, 2012 E-mail Correspondence

Manitoba Water Stewardship, Fisheries Branch – February 13, 2012 E-mail Correspondence

Manitoba Conservation Wildlife and Ecosystem Protection Branch, January 30, 2012 E-mail Correspondence

Manitoba Conservation Historic Resources Branch, February 6, 2012 Memorandum

Appendix D

Title Page

Plan 1: Proposed Lagoon Layout with Test Hole Locations and Topographic Contour Lines

Plan 2: Proposed Lagoon Discharge Route

Plan 3: Proposed Lagoon Layout

Plan 4: Perimeter Dike, Intercell Dike, Valve, Valve Marker, Sign, Rip Rap, Ditch and Access Road Details

Plan 5: Spillway, Truck Turnaround, Silt Fence, Fence, Gate and Lock Details

Appendix A

Crown Lands and Property Agency - Lands Branch, February 1, 2012
E-mail Correspondence

Brett McCormac

From: Little, Karen (CLP) [Karen.Little@gov.mb.ca]
Sent: February 1, 2012 2:53 PM
To: 'Brett McCormac'
Subject: RE: South Whiteshell Truck Haul Lagoon - Mines and Minerals

Good afternoon Brett, according to the Crown Land Registry this date, all mines & minerals, sand & gravel in SE & SW 19-8-16 EPM are owned by Crown Manitoba. The administration & control of these parcels are with Parks Branch as they are within the Whiteshell Provincial Park boundary.

Sincerely,

Karen Little

Supervisor of Crown Lands Registry
Crown Lands and Property Agency
308 - 25 Tupper Street North
Portage la Prairie MB R1N 3K1
P (204) 239-3805 F (204) 239-3560
Toll Free 1-866-210-9589
karen.little@gov.mb.ca



An Agency of MB Infrastructure and Transportation

From: Brett McCormac [<mailto:bmccormac@jrcc.ca>]
Sent: January-30-12 9:51 AM
To: Little, Karen (CLP)
Subject: South Whiteshell Truck Haul Lagoon - Mines and Minerals

Hi Karen,

J.R. Cousin Consultants Ltd. (JRCC) is preparing an Environmental Act Proposal for the South Whiteshell truck haul lagoon to service West Hawk, Falcon Lake and the surrounding area. The lagoon is proposed to be located within the Whiteshell Provincial Park on the SE1/4 or the SW1/4 of 19-08-16-E.

Could you please confirm the owner of the mineral rights for this property.

Thank you,

Brett McCormac, E.I.T.
Environmental Engineer-in-Training

J.R. Cousin Consultants Ltd.
Phone: (204) 489-0474
Fax: (204) 489-0487
www.jrcc.ca

Appendix B

Geotechnical and Topographic Investigation for the South Whiteshell
Truck Haul Lagoon

SOUTH WHITESHELL
Geotechnical and Topographic Investigation
for the
South Whiteshell Truck Haul Lagoon

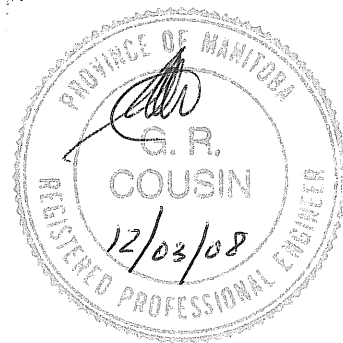
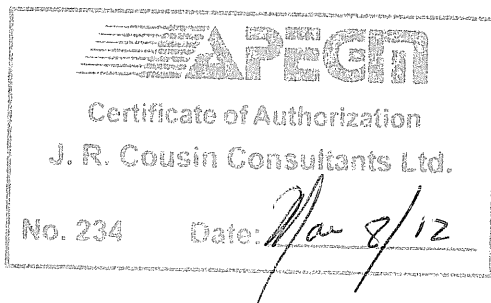

Prepared by:

J. R. Cousin Consultants Ltd.
91A Scurfield Blvd.
Winnipeg, Manitoba
R3Y 1G4

March 2012

ACKNOWLEDGMENTS

To prepare this report various sources of information were investigated and researched. The firm of J. R. Cousin Consultants Ltd. wishes to thank the MWSB and the Parks and Natural Areas Branch of Manitoba Conservation who assisted with organization and onsite works.

REMARKS

Conclusions reached in this report are based upon the generalization of data available to us at the time of forming our opinions. Information in this document may rely on previous studies, investigative work and data by others. JRCC cannot be responsible for actual site conditions proved to be at variance with any generalized data. This report was completed in accordance with generally accepted professional engineering principles and practice. Any use of this report by a third party is the responsibility of the third party, JRCC accepts no responsibility for third party decisions or actions based on the report. No other warranty or guarantee expressed, implied or statutory is made.

© Copyright J. R. Cousin Consultants Ltd., 2012

Information contained herein is confidential and may not be released to a third party without express permission of J. R. Cousin Consultants Ltd.

TABLE OF CONTENTS

Section	Page
1.0 INTRODUCTION.....	1
2.0 BACKGROUND	1
2.1 Past Geotechnical Investigations.....	1
2.1.1 Cochrane, 2006.....	1
2.1.2 JRCC, 1995	2
2.1.3 Department of Natural Resources, 1988	2
2.1.4 GW Driller’s Well Logs.....	2
3.0 TOPOGRAPHIC INVESTIGATION.....	2
4.0 GEOTECHNICAL FIELD INVESTIGATION.....	3
4.1 Soil Profile.....	3
4.1.1 Site A.....	3
4.1.2 Site B.....	4
4.2 Groundwater.....	4
5.0 LABORATORY TESTING AND ANALYSIS AND DISCUSSION	4
6.0 LAGOON LINER REQUIREMENTS	5
6.1 Current Guidelines	5
6.2 Typical Lagoon Liner Construction Options.....	6
6.3 Lagoon Liner for the South Whiteshell Truck Haul Lagoon	6
7.0 SUMMARY AND RECOMMENDATIONS.....	7
7.1 Summary	7
7.2 Recommendations	7
7.3 Closure	8

APPENDIX

Plan 1: Proposed Lagoon with Test Hole Locations and Topographic Contour Lines

Driller’s Well Logs

Test Hole Logs

The National Testing Laboratories Limited Test Results, dated December 16, 2011

1.0 INTRODUCTION

J. R. Cousin Consultants Ltd. (JRCC) conducted a topographic and geotechnical investigation for the proposed new South Whiteshell truck-haul wastewater treatment lagoon. Two sites for the proposed new lagoon were investigated including Site A: immediately southwest of the South Whiteshell Waste Transfer Station located in the SE ¼ of 19-08-16-E and Site B: at the boundary between the Whiteshell Provincial Park and the R.M. of Reynolds in the SW ¼ of 19-08-16-E.

Seven test holes were excavated around Site A and three test holes were excavated at Site B at various locations to determine the suitability of the soils for use as a clay lagoon liner. Test hole locations are shown on Plan 1 attached in the Appendix.

This report outlines the findings of the geotechnical and topographic investigation at the proposed new lagoon sites and evaluates the soils to determine their suitability for use as a lagoon liner as well as any potential difficulties associated with construction.

2.0 BACKGROUND

The South Whiteshell truck haul lagoon will service the cottage and business communities on holding tanks and septic tanks in the Falcon Lake Park District (includes Falcon Lake and Barren Lake) and the West Hawk Lake Park District (includes West Hawk, Caddy Lake, Star Lake, Hunt Lake, Florence Lake and Nora Lake).

2.1 Past Geotechnical Investigations

2.1.1 Cochrane Engineering Ltd., 2006

A geotechnical investigation was completed by Cochrane Engineering Ltd. in April 2006 at the proposed lagoon location. A total of 7 test pits were excavated utilizing a backhoe. The general soil profile observed was a topsoil/peat layer followed by a thin silty clay layer and a clay layer to the bottom of the test hole (2.4 – 4.6 m below ground). One of the test holes located at the north of the testing area found a sandy till beyond the clay layer. Two samples from the clay layer and one sample from the silty clay layer were sent for laboratory analysis. The sample from the silty clay layer was deemed a CLAYEY SILT with a clay content of 32.1%. The samples from the clay layer had an average Plasticity Index of 36.5 and an average clay content of 68.1%. Although the material was high plastic, in-situ it was deemed not able to meet the Manitoba Conservation guideline of a hydraulic conductivity of 1×10^{-7} cm/sec due to well defined fissures. It was recommended the material be scarified, mixed and compacted to meet the guideline.

2.1.2 J. R. Cousin Consultants Ltd., 1995

A geotechnical investigation was completed by JRCC at and near the existing Falcon Lake Waste Transfer Station (WTS) in February 1995. A total of five test holes were excavated around the existing WTS site and one test hole was excavated at a potential borrow area. The test hole (TH1) excavated closest to the proposed lagoon location consisted of silty clay to a depth of 1.8 m followed by grey medium to high plastic clay to a depth of 9.4 m followed by low plastic silty clay to a depth of 10.7 m followed by medium plastic silty clay to the bottom of the test hole at 12.2 m. The soil profile of the test holes taken east of the WTS site consisted of a thin layer of sand and gravel followed by medium to high plastic silty clay followed by high plastic clay followed by silty and sandy soils to the bottom of the test holes. No laboratory analysis was completed on the soil samples.

2.1.3 Department of Natural Resources, 1988

A geotechnical investigation for the existing South Whiteshell WTS was completed by the Province of Manitoba's Department of Natural Resources Engineering and Construction Branch in February of 1988. The average soil profile consisted of 0.15 to 1.5 m of topsoil/peat followed by up to 13.4 m of low to medium plastic clay. The upper clay was found to be mainly medium plastic with the low plastic clay occurring below 3.7 – 9.1 m. The Plasticity Index of the medium plastic clay ranged from 23 – 32 with an average of 26.

2.1.4 GW Driller's Well Logs

Driller's Well logs from 21-08-16E were reviewed which are the closest well logs to the proposed lagoon site, approximately 3.2km east of the site. The well logs indicate the soil profile consists of varying layers of clay, silt and sand underlain with gravel and boulders. Bedrock was encountered in 5 wells with depths ranging from 2.1 m to 30.8 m. The average static groundwater level recorded in the wells was 2.4 m below the ground surface.

3.0 TOPOGRAPHIC INVESTIGATION

A topographic GPS survey of the test hole locations and selected existing ground locations across both proposed lagoon sites (sites A and B) was completed on November 9, 2011 along with the geotechnical investigation. From the topographic survey data, the existing ground elevation at Site A was relatively flat with an average elevation of 335.3 m. The elevations varied across the site from 334.7 m to 335.8 m. The existing ground is sloped to the southwest of the existing WTS. A pond/wetland area was observed southeast of the existing WTS approximately 70 m northwest of the TransCanada Highway. A bedrock outcrop with a peak elevation of 336.95 m was observed approximately 150 m southwest of the pond.

The average elevation of the existing ground at the park boundary (Site B) was found to be 333.2 m. The surrounding area was observed to be relatively flat.

Contour lines from the topographic survey are shown on Plan 1 attached in the Appendix.

4.0 GEOTECHNICAL FIELD INVESTIGATION

The onsite geotechnical investigation for the proposed new lagoon was conducted on November 9, 2011. S.E.G. Enterprises Ltd. was employed to conduct the test hole excavations using a track-mounted excavator under direct supervision by JRCC's field representative.

Nine test holes were excavated during the geotechnical investigation. Six test holes (TH1 – TH6) were excavated at the proposed lagoon Site A and three test holes (TH7 – TH9) were excavated around the proposed lagoon Site B. Test holes were excavated to a depth of approximately 5.3 m or to bedrock refusal. Test hole locations are shown on Plan 1 in the Appendix. Test hole locations were limited by large tree stands which made access difficult to some areas of Site A and the majority of Site B.

The subsurface soil profile within each test hole was logged, water conditions were noted and representative soil samples were collected as the soils varied along the profile. The samples were visually field-classified. Six selected bagged soil samples from the test holes were sealed and submitted to The National Testing Laboratories Ltd. (NTL) for testing. One bagged soil sample (TH1 0.6 – 2.3 m) was also sent to NTL to be re-worked, re-compacted and tested to determine the hydraulic conductivity. Details of the laboratory analysis are provided below in Section 5.0. Following completion of excavation, an assessment of the short term groundwater conditions was completed. All test holes were then backfilled with the excavated material.

4.1 Soil Profile

Based on the soils observed in the test holes the general soil profile across both sites consists of a topsoil layer followed by medium plastic lean clay with some silt and sand followed by a medium plastic fat clay with varying levels of silt, sand and gravel. Bedrock was encountered at two of the test holes at depths of 3.4 m and 2.7 m.

Details of each individual soil profile, including depth and description of each layer as well as comments on bedrock and groundwater infiltration can be found in the test hole logs attached in the Appendix.

4.1.1 Site A

The detailed soil profile from TH1 – TH6 taken across Site A consisted of an average of 0.6 m of topsoil followed by an average of 1.3 m of a medium plastic lean clay, soft, grey, fissured/blocky structure with varying levels of silt, sand and trace gravel. The layer that followed was a medium plastic, firm clay, fissured/blocky structure with silt

and trace sand and gravel observed to be an average of 1.4 m thick. The final layer was a medium to high plastic clay, fissured/blocky structure with silt, sand and some gravel observed to a maximum depth of 5.3 m. Bedrock was encountered on TH4 at a depth of 3.4 m.

4.1.2 Site B

The soil profiles on Site B from TH7 – TH9 were varied across the test area. TH7 had a 0.5 m thick layer of topsoil followed by silty sandy soil with trace low plastic clay to a depth of 3.1 m which was followed by a high plastic clay with some silt and trace sand and gravel to a depth of 5.1 m. TH8 had a 0.3 m thick layer of topsoil followed by medium plastic clay, fissured/blocky structure with silt and trace sand and gravel to a depth of 2.7 m. The final layer was a medium to high plastic clay, fissured/blocky structure with silt, sand and some gravel observed to a depth of 5.1 m. TH9 had 0.5 m of topsoil followed by a medium plastic clay, fissured/blocky structure with silt and trace sand and gravel and some large rocks and stones to a depth of 2.7 m, where bedrock was encountered.

4.2 Groundwater

Short-term groundwater conditions were assessed in each test hole by observing infiltrating water into the test holes prior to backfilling. Caving and sloughing of the test hole walls was also observed and recorded. Water infiltration was observed in TH2 at 1.8 m and TH3 at 5.1 m. Caving of the test hole walls was observed in TH2 at 0.6 m, TH3 at 0.8 m and TH7 at 0.5 m.

Groundwater in the test holes depends on high static groundwater conditions and on seasonal conditions, i.e. snowmelt and rainy seasons. Other assumptions relating to the groundwater elevation cannot be made at this time, as water levels will normally fluctuate seasonally.

Contractors will be made aware of the geotechnical conditions encountered onsite, as dewatering may be required during construction, depending on the depth of excavation determined during final design.

5.0 LABORATORY TESTING AND ANALYSIS AND DISCUSSION

Representative soil samples from the proposed lagoon site were submitted to The National Testing Laboratories Limited (NTL) for testing and analysis. The testing and analysis included determining the following:

- Atterberg Limits (plastic limit, liquid limit, and plasticity index, ASTM D4318)
- Soil Classification (ASTM D2487)
- Moisture Content (ASTM D2216)

- Particle Size Analysis (Hydrometer test, ASTM D422).

The re-worked and re-compacted Shelby tube sample was subjected to a Hydraulic Conductivity test (ASTM D5084-03).

Laboratory analysis of the bagged soil samples indicated that three of the soil samples were deemed a lean clay and the other three were deemed a fat clay. The Plasticity Index of the samples varied between 29 and 39 and the percentage of clay varied between 66.1% and 70.3%. Based on past experience, the laboratory has commented that homogeneous soils with a plasticity index greater than 25 and a clay content greater than 50% would typically be expected to have a hydraulic conductivity of 1×10^{-7} cm/sec or less. Plasticity index analysis (i.e. Atterberg limits) of the soils indicated that all of the bagged soil samples submitted were considered to have potential for use as an insitu clay liner or a re-moulded and re-compacted clay liner. See Table 1 of the NTL Test Results in the Appendix.

NTL indicates that the bagged soil samples suitability for use as a clay liner is dependent upon the soils being homogeneous with no preferential flow paths. It is also noted that estimating the hydraulic conductivity of a soil based upon classification test results (Plasticity Index and particle size analysis) alone might be misleading if the soil contains layers of sand, silt, or organic material. These silt, and sand layers along with rocks or boulders or fissures in the soil can create preferential flow paths which can lead to an increased hydraulic conductivity.

The bagged soil sample from TH1 0.6 – 2.3 m was re-worked and re-compacted and tested for hydraulic conductivity by the NTL for potential use as a re-worked lagoon liner. The sample achieved a re-worked hydraulic conductivity (k_{20}) of 7.7×10^{-9} cm/sec. The sample had a lower hydraulic conductivity than the Manitoba Conservation requirement of 1×10^{-7} cm/sec and therefore would be suitable for use as a re-worked and re-compacted lagoon liner.

Details of National Testing Laboratories test results and analysis, dated December 16, 2011 are attached in the Appendix.

6.0 LAGOON LINER REQUIREMENTS

6.1 Current Guidelines

Manitoba Conservation guidelines require that a standard wastewater lagoon clay liner be 1.0 metre in thickness and have a hydraulic conductivity (i.e. the potential rate of fluid movement through the soil) of 1×10^{-7} cm/sec or less. This low rate is to protect the underlying groundwater from lagoon seepage. Generally, the higher a soil's plasticity the more likely a soil can achieve a hydraulic conductivity of 1×10^{-7} cm/sec.

6.2 Typical Lagoon Liner Construction Options

The liner of a lagoon can be constructed by using the insitu (undisturbed) soils if the soils can consistently achieve a hydraulic conductivity of 1×10^{-7} cm/sec or less in their insitu conditions.

If the insitu soils cannot be used, the liner can be constructed by excavating and re-compacting suitable high plastic clay soils to form the liner.

If the clay content of the soils is so low that even when excavated and re-compacted, the soils cannot consistently achieve a hydraulic conductivity of 1×10^{-7} cm/sec, a liner constructed of high plastic clay from a borrow pit, or a synthetic geomembrane liner would be required.

6.3 Lagoon Liner for the South Whiteshell Truck Haul Lagoon

Based on the laboratory Plasticity Index analysis, all of the bagged soil samples submitted, from both Site A and Site B, have potential for use as an insitu lagoon liner or a re-worked and re-compacted lagoon liner.

Based on site observations during the geotechnical investigation the soil samples had layers of silt, sand and gravel and had a blocky, fissured structure which can cause preferential flow paths and increased hydraulic conductivity. Constructing the lagoon with an insitu clay liner would carry significant risk of not meeting the hydraulic conductivity guideline across the site.

When the soil is re-worked and re-compacted the soils are mixed and the structure is altered to create a liner with much lower hydraulic conductivity than the insitu soils. The lagoon liner could be constructed by re-working and re-compacting a minimum 1.0 m thick clay liner. The soils at the site were deemed to have potential for use a re-worked and re-compacted clay liner by laboratory analysis on the bagged samples. This potential was verified by the re-worked and re-compacted Shelby tube sample from TH1 0.6 – 2.3 m which achieved a hydraulic conductivity of 7.7×10^{-9} cm/sec.

If the low plastic clay soils are encountered during liner construction such as the soil layer from TH7 0.5 – 3.1 at either site, high plastic clay borrow material may be required to replace the low plastic clay for construction of the lagoon liner.

Depending on final lagoon design elevations, the bedrock encountered on TH4 and TH9 may impact the location of the proposed lagoon.

Overburden soils excavated from the site could be used for the dike construction and medium-high plastic soils from the cell floor area would be excavated and re-compacted and re-worked to create the vertical cut-off walls.

If the lagoon is constructed on Site B, additional test holes will be required to determine the extent of the low plastic clay layer found in TH7, to further evaluate soil conditions elsewhere in

the lagoon footprint and to evaluate any shallow bedrock elevations as encountered on TH4 and TH9.

7.0 SUMMARY AND RECOMMENDATIONS

7.1 Summary

The topography of the proposed lagoon site varies between an elevation of approximately 334.7 m and 335.8 m above sea level. Site A was relatively flat with a slope to the southwest of the existing WTS. The average elevation of Site B was 333.2 m and was relatively flat.

Soils at the proposed lagoon site were investigated by JRCC. Representative soil samples were analyzed by National Testing Laboratories Ltd. to determine their suitability for use as an insitu lagoon liner or a re-worked and re-compacted lagoon liner.

Based on the laboratory Plasticity Index analysis, of all the bagged soil samples submitted, from both Site A and Site B, have potential for use as an insitu lagoon liner or a re-worked and re-compacted lagoon liner. However, based on site observations during the geotechnical investigation the soil samples had layers of silt, sand and gravel and had a blocky, fissured structure which can cause preferential flow paths and increased hydraulic conductivity. A re-worked and re-compacted Shelby tube sample from TH1 0.6 – 2.3 m achieved a hydraulic conductivity of 7.7×10^{-9} cm/sec which indicates the soils would be suitable for a re-worked and re-compacted clay lagoon liner.

7.2 Recommendations

It is recommended that the lagoon liner on either Site A or Site B be constructed by re-working and re-compacting a minimum 1.0 m thick clay liner. The soils at the site were deemed to have potential for use of a re-worked and re-compacted clay liner by laboratory analysis on the bagged samples. This potential was verified by the re-worked and re-compacted Shelby tube sample from TH1 0.6 – 2.3 m which achieved a hydraulic conductivity of 7.7×10^{-9} cm/sec.

If the low plastic clay soils are encountered during liner construction such as the soil layer from TH7 0.5 – 3.1 at either site, high plastic clay borrow material may be required to replace the low plastic clay for construction of the lagoon liner.

Overburden soils excavated from the site could be used for the dike construction and medium-high plastic soils from the cell floor area would be excavated and re-compacted and re-worked to create the vertical cut-off walls.

If the lagoon is constructed on Site B, additional test holes will be required to determine the extent of the low plastic clay layer found in TH7, to further evaluate soil conditions elsewhere in

the lagoon footprint and to evaluate any shallow bedrock elevations as encountered on TH4 and TH9.

7.3 Closure

The conclusions and recommendations in this report are based on the results of the site investigation and laboratory analysis. In addition, soil and groundwater conditions between test hole locations were generalized to provide an overall assessment of the geotechnical site conditions. If conditions that appear different from those encountered at the test hole locations as described in this report, or if the assumptions stated herein are not in agreement with the design, JRCC should be informed in order that the recommendations can be reviewed and adjusted as required.

The geotechnical investigation and topographic review was conducted for identifying geotechnical and topographic conditions suitable for construction of a South Whiteshell truck haul lagoon. Although no environmental issues were identified during the geotechnical investigation and topographic review, it does not necessarily follow that such issues do not exist. If the client or any other parties have any environmental concerns regarding the proposed site and works, an appropriate environmental assessment must be conducted.

It is not uncommon for soil conditions to be highly variable across a site. Previous construction activities and placement of fill at a site can augment the variability of soil conditions, especially surficial soil conditions. A contingency must be included in any construction budget to allow for potential variations in soil conditions, which may result in modification of the design and construction procedures.

APPENDIX

Plan 1: Proposed Lagoon with Test Hole Locations and Topographic Contour Lines

Driller's Well Logs

Test Hole Logs

The National Testing Laboratories Limited Test Results, dated December 16, 2011

Plan 1: Proposed Lagoon with Test Hole Locations and Topographic Contour Lines

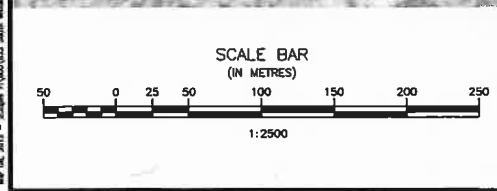

No.	REVISIONS	DATE	INITIALS

B.M. ELEV.

LOCATIONS OF UNDERGROUND STRUCTURES/UTILITIES AS SHOWN ARE BASED ON AVAILABLE INFORMATION BUT NO GUARANTEE IS GIVEN OR IMPLIED THAT ALL EXISTING UNDERGROUND STRUCTURES/UTILITIES ARE SHOWN OR THAT THE GIVEN LOCATIONS ARE EXACT. CONFIRMATION OF EXISTENCE AND EXACT LOCATION OF ALL UNDERGROUND STRUCTURES/UTILITIES MUST BE OBTAINED FROM THE APPROPRIATE AUTHORITY/OWNER, BY THE CONTRACTOR, BEFORE PROCEEDING WITH CONSTRUCTION.

ENGINEER'S SEAL

PRELIMINARY

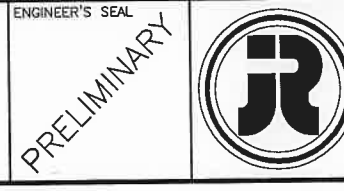

J. R. Cousin Consultants Ltd.
Consulting Engineers and Project Managers

91A Scurfield Blvd. Winnipeg, MB R3Y 1G4
ph: (204) 489-0474 fax: (204) 489-0487
email: info@jrcc.ca website: www.jrcc.ca

Engineering Excellence since 1981

CODE: S-633.01	PROJECT: SOUTH WHITESHELL PROVINCIAL PARK TRUCKHAUL LAGOON FEASIBILITY STUDY
DESIGNED BY: JC	TITLE: PROPOSED LAGOON WITH TEST HOLE LOCATIONS AND TOPOGRAPHIC CONTOUR LINES
DRAWN BY: BM	SCALE: 1:2500
REVIEWED BY: JC	DATE: 12/02/29
	PLAN: 1
	SHEET: 1 of 1

12/02/29 12:00 PM C:\Users\jrc\Documents\Projects\South Whiteshell Provincial Park\Truckhaul Lagoon Feasibility Study\04 - Drawings\01 - General\Plan 1.dwg

Driller's Well Logs

LOCATION: 21-8-16E

Well_PID: 19824
Owner: PARKS BRANCH
Driller: M & M Drilling Rivers Ltd.
Well Name: F-1
Well Use: TEST WELL
Water Use:
UTMX: 763255.615
UTMY: 5508588.69
Accuracy XY: UNKNOWN
UTMZ:
Accuracy Z:
Date Completed: 1973 Jun 26

WELL LOG

From (ft.)	To (ft.)	Log
0	3.0	SAND
3.0	6.0	CLAY-BROWN
6.0	11.0	SAND-COARSE
11.0	13.0	CLAY-WHITE OR LIGHT BROWN
13.0	14.0	CLAY-LIGHT GREY
14.0	22.0	SAND& GRAVEL COARSE,GREY
22.0	25.0	BOULDERS& COARSE GRAVEL BEDROCK AT 25 FEET

WELL CONSTRUCTION

From (ft.)	To (ft.)	Casing Type	Inside Dia.(in)	Outside Dia.(in)	Slot Size(in)	Type	Material
0	15.0	casing	2.00				
15.0	21.0	perforations	2.00			SL. PIPE	

Top of Casing: ft. below ground

PUMPING TEST

Date:
Flowing Rate: 30.0 Imp. gallons/minute
Water level before pumping: ft. below ground
Pumping level at end of test: ?? ft. below ground
Test duration: 2 hours, 30 minutes
Water temperature: ?? degrees F

REMARKS

FALCON LAKE, GROUP USE CAMPGROUND, FIELD ANALYSIS, T=46500 IGPD/FT

LOCATION: 21-8-16E

Well_PID: 19829
Owner: PARKS BRANCH
Driller: M & M Drilling Rivers Ltd.
Well Name: F-2
Well Use: TEST WELL
Water Use:
UTMX: 763255.615
UTMY: 5508588.69
Accuracy XY: UNKNOWN
UTMZ:
Accuracy Z:
Date Completed: 1973 Jun 26

WELL LOG

From (ft.)	To (ft.)	Log
0	11.0	SAND
11.0	12.0	CLAY-BROWN
12.0	13.0	SAND
13.0	30.0	BOULDERS GRAVEL& SAND

No construction data for this well.

Top of Casing: ft. below ground

No pump test data for this well.

REMARKS

FALCON LAKE, GROUP USE CAMPGROUND, FIELD ANALYSIS

LOCATION: 21-8-16E

Well_PID: 19828
Owner: PARKS BRANCH
Driller: M & M Drilling Rivers Ltd.
Well Name: F-3A & F-3B
Well Use: TEST WELL
Water Use:
UTMX: 763255.615
UTMY: 5508588.69
Accuracy XY: UNKNOWN
UTMZ:
Accuracy Z:
Date Completed: 1973 Jun 27

WELL LOG

From (ft.)	To (ft.)	Log
0	3.0	SAND
3.0	5.0	CLAY-BROWN
5.0	7.0	BOULDERS BEDROCK AT 7 FEET

No construction data for this well.

Top of Casing: ft. below ground

No pump test data for this well.

REMARKS

FALCON LAKE, GROUP USE CAMPGROUND

LOCATION: 21-8-16E

Well_PID: 19827
 Owner: PARKS BRANCH
 Driller: M & M Drilling Rivers Ltd.
 Well Name: F-4
 Well Use: TEST WELL
 Water Use:
 UTMX: 763255.615
 UTM Y: 5508588.69
 Accuracy XY: UNKNOWN
 UTM Z:
 Accuracy Z:
 Date Completed: 1973 Jun 27

WELL LOG

From (ft.)	To (ft.)	Log
0	5.0	CLAY-BROWN
5.0	10.0	CLAY-WHITE SOFT
10.0	26.0	SAND-FINE
26.0	35.0	CLAY-SOFT GREY SILTY
35.0	70.0	CLAY-FIRM GREY
70.0	94.9	CLAY-SOFT SILTY
94.9	96.9	STONES& CLAY
96.9	97.9	SAND
97.9	109.9	COARSE SAND, GRAVEL, AND BOULDERS

WELL CONSTRUCTION

From (ft.)	To (ft.)	Casing Type	Inside Dia.(in)	Outside Dia.(in)	Slot Size(in)	Type	Material
0	100.9	casing	2.00				
100.9	106.9	perforations	2.00			SL. PIPE	

Top of Casing: ft. below ground

PUMPING TEST

Date:
Flowing Rate: 15.0 Imp. gallons/minute
Water level before pumping: ft. below ground
Pumping level at end of test: ?? ft. below ground
Test duration: 3 hours, minutes
Water temperature: ?? degrees F

REMARKS

FALCON LAKE, GROUP USE CAMPGROUND, CHEMICAL ANALYSIS, T=10400 IGPD/FT

LOCATION: 21-8-16E

Well_PID: 19832
Owner: PARKS BRANCH
Driller: M & M Drilling Rivers Ltd.
Well Name: F-5
Well Use: TEST WELL
Water Use:
UTMX: 763255.615
UTMY: 5508588.69
Accuracy XY: UNKNOWN
UTMZ:
Accuracy Z:
Date Completed: 1973 Jun 29

WELL LOG

From (ft.)	To (ft.)	Log
0	5.0	CLAY-BROWN
5.0	10.0	CLAY-WHITE SOFT
10.0	26.0	SILTY SAND

WELL CONSTRUCTION

From (ft.)	To (ft.)	Casing Type	Inside Dia.(in)	Outside Dia.(in)	Slot Size(in)	Type	Material
0	20.0	casing	2.00				
10.0	26.0	gravel pack				NO. 15	SILICA
S.	20.0	26.0 perforations		2.00	0.020	WIRE WOUND	

Top of Casing: ft. below ground

PUMPING TEST

Date:
Flowing Rate: 10.0 Imp. gallons/minute
Water level before pumping: ft. below ground
Pumping level at end of test: ?? ft. below ground
Test duration: 1 hours, minutes
Water temperature: ?? degrees F

REMARKS

FALCON LAKE, GROUP USE CAMPGROUND, FIELD ANALYSIS, T=2930 IGPD/FT

LOCATION: 21-8-16E

Well_PID: 19831
Owner: PARKS BRANCH
Driller: M & M Drilling Rivers Ltd.
Well Name: F-6
Well Use: TEST WELL
Water Use:
UTMX: 763255.615
UTMY: 5508588.69
Accuracy XY: UNKNOWN
UTMZ:
Accuracy Z:
Date Completed: 1973 Jul 03

WELL LOG

From (ft.)	To (ft.)	Log
0	5.0	CLAY-BROWN
5.0	14.0	SAND-MEDIUM FINE,BROWN
14.0	35.0	SAND-SILTY; GREY
35.0	41.0	CLAY-SOFT GREY
41.0	43.0	SAND
43.0	75.0	CLAY-SOFT SILTY,GREY

WELL CONSTRUCTION

From (ft.)	To (ft.)	Casing Type	Inside Dia.(in)	Outside Dia.(in)	Slot Size(in)	Type	Material
0	29.0	casing	2.00			INSERT	BLACK
29.0	35.0	perforations	2.00		0.020	WIRE WOUND	S. S.

Top of Casing: ft. below ground

PUMPING TEST

Date:

Flowing Rate: 2.0 Imp. gallons/minute
Water level before pumping: ft. below ground
Pumping level at end of test: ?? ft. below ground
Test duration: hours, minutes
Water temperature: ?? degrees F

REMARKS

FALCON LAKE, GROUP USE CAMPGROUND, ZONE 14-35 FT UNABLE TO PUMP

LOCATION: 21-8-16E

Well_PID: 19830
Owner: PARKS BRANCH
Driller: M & M Drilling Rivers Ltd.
Well Name: F-7
Well Use: TEST WELL
Water Use:
UTMX: 763255.615
UTMY: 5508588.69
Accuracy XY: UNKNOWN
UTMZ:
Accuracy Z:
Date Completed: 1973 Jul 03

WELL LOG

From (ft.)	To (ft.)	Log
0	5.0	CLAY-SANDY BROWN
5.0	6.0	SAND-BROWN
6.0	14.0	CLAY-WHITE FIRM
14.0	24.0	SAND-MEDIUM GRAINED SILTY, GREY SOFT CLAY AT 24 FEET

WELL CONSTRUCTION

From (ft.)	To (ft.)	Casing Type	Inside Dia.(in)	Outside Dia.(in)	Slot Size(in)	Type	Material
0	18.0	casing	2.00				BLACK
18.0	24.0	perforations	2.00		0.020	WIRE WOUND	S. S.

Top of Casing: ft. below ground

PUMPING TEST

Date:
Flowing Rate: 8.0 Imp. gallons/minute
Water level before pumping: ft. below ground
Pumping level at end of test: ?? ft. below ground
Test duration: 1 hours, minutes

Water temperature: ?? degrees F

REMARKS

FALCON LAKE, GROUP USE CAMPGROUND, FIELD ANALYSIS, T=1620 IGPD/FT

LOCATION: 21-8-16E

Well_PID: 19835
Owner: PARKS BRANCH
Driller: M & M Drilling Rivers Ltd.
Well Name: F-8
Well Use: TEST WELL
Water Use:
UTMX: 763255.615
UTMY: 5508588.69
Accuracy XY: UNKNOWN
UTMZ:
Accuracy Z:
Date Completed: 1973 Jul 03

WELL LOG

From (ft.)	To (ft.)	Log
0	6.0	CLAY-SANDY BROWN, SOFT
6.0	27.0	SAND-BROWN FINE
27.0	35.0	CLAY-SILTY, GREY
35.0	47.0	CLAY-SANDY, WHITE, FIRM
47.0	73.0	CLAY-SANDY, GREY, SOFT
73.0	96.9	SILT-GREY
96.9	100.9	BOULDERS& GREY CLAY BEDROCK AT 101 FEET

WELL CONSTRUCTION

From (ft.)	To (ft.)	Casing Type	Inside Dia.(in)	Outside Dia.(in)	Slot Size(in)	Type	Material
0	21.0	casing	2.00			INSERT	BLACK
21.0	27.0	perforations	2.00		0.020	WIRE WOUND	S. S.

Top of Casing: ft. below ground

PUMPING TEST

Date:
Flowing Rate: 3.0 Imp. gallons/minute
Water level before pumping: ft. below ground
Pumping level at end of test: ?? ft. below ground
Test duration: 1 hours, 15 minutes
Water temperature: ?? degrees F

REMARKS

FALCON LAKE, GROUP USE CAMPGROUND, FIELD ANALYSIS

LOCATION: 21-8-16E

Well_PID: 19834
Owner: PARKS BRANCH
Driller: M & M Drilling Rivers Ltd.
Well Name: F-9
Well Use: TEST WELL
Water Use:
UTMX: 763255.615
UTMY: 5508588.69
Accuracy XY: UNKNOWN
UTMZ:
Accuracy Z:
Date Completed: 1973 Jul 04

WELL LOG

From (ft.)	To (ft.)	Log
0	12.0	CLAY-BROWN SANDY
12.0	18.0	CLAY-SOFT GREY SILTY
18.0	28.0	SILTY SAND-FINE, GREY
28.0	32.0	CLAY-SANDY, GREY
32.0	41.0	SAND-CLEAN, FINE
41.0	45.0	CLAY-SOFT GREY

WELL CONSTRUCTION

From (ft.)	To (ft.)	Casing Type	Inside Dia.(in)	Outside Dia.(in)	Slot Size(in)	Type	Material
0	35.0	casing	2.00			INSERT	BLACK
IRON							
30.0	45.0	gravel pack					GRAVEL
35.0	41.0	perforations	2.00		0.020	WIRE WOUND	S. S.

Top of Casing: ft. below ground

PUMPING TEST

Date:
Flowing Rate: 15.0 Imp. gallons/minute
Water level before pumping: ft. below ground
Pumping level at end of test: ?? ft. below ground
Test duration: 3 hours, minutes
Water temperature: ?? degrees F

REMARKS

FALCON LAKE, GROUP USE CAMPGROUND, FIELD ANALYSIS, T=1620 IGPD/FT

LOCATION: 21-8-16E

Well_PID: 19833
Owner: PARKS BRANCH
Driller: M & M Drilling Rivers Ltd.
Well Name: WELL #1 @ F-1 SITE
Well Use: PRODUCTION
Water Use: Other
UTMX: 763255.615
UTMY: 5508588.69
Accuracy XY: UNKNOWN
UTMZ:
Accuracy Z:
Date Completed: 1973 Jun 28

WELL LOG

From (ft.)	To (ft.)	Log
0	3.0	SAND
3.0	6.0	CLAY-BROWN
6.0	11.0	SAND-COARSE
11.0	13.0	CLAY-LIGHT BROWN
13.0	14.0	CLAY-LIGHT GREY
14.0	22.0	COARSE GREY SAND& GRAVEL
22.0	25.0	BOULDERS& COARSE GRAVEL BEDROCK AT 25 FEET

WELL CONSTRUCTION

From (ft.)	To (ft.)	Casing Type	Inside Dia.(in)	Outside Dia.(in)	Slot Size(in)	Type	Material
0	19.0	casing	5.50			INSERT	BLACK
IRON							
8.0	24.0	gravel pack				NO. 15	SILICA
S.							
19.0	24.0	perforations		5.00	0.018	WIRE WOUND	S. S.

Top of Casing: ft. below ground

PUMPING TEST

Date:
Pumping Rate: 35.0 Imp. gallons/minute
Water level before pumping: 8.0 ft. below ground
Pumping level at end of test: 16.0 ft. below ground
Test duration: 1 hours, minutes
Water temperature: ?? degrees F

REMARKS

MPWI-ER-WHITESHELL-FALCON LAKE CAMPGROUND AREA 1-UNKNOWN WELL. FALCON LAKE, GROUP USE CAMPGROUND, WELL INSTALLED AT TEST HOLE F-1 (1973) SITE. FIELD ANALYSIS

LOCATION: 21-8-16E

Well_PID: 19838
Owner: PARKS BRANCH
Driller: M & M Drilling Rivers Ltd.
Well Name: WELL #2 @ F-9 SITE
Well Use: PRODUCTION
Water Use: Other
UTMX: 763255.615
UTMY: 5508588.69
Accuracy XY: UNKNOWN
UTMZ:
Accuracy Z:
Date Completed: 1973 Jul 04

WELL LOG

From (ft.)	To (ft.)	Log
0	12.0	CLAY-BROWN SANDY
12.0	18.0	CLAY-SOFT GREY SILTY
18.0	28.0	SILTY SAND-FINE,GREY
28.0	32.0	CLAY-SANDY,GREY WASHED
32.0	41.0	SAND-CLEAN,FINE
41.0	45.0	CLAY-SOFT GREY

WELL CONSTRUCTION

From (ft.)	To (ft.)	Casing Type	Inside Dia.(in)	Outside Dia.(in)	Slot Size(in)	Type	Material
0	36.0	casing	5.50			INSERT	BLACK
IRON							
22.0	42.0	gravel pack				NO. 15	SILICA
S.							
36.0	41.0	perforations	5.00		0.018	WIRE WOUND	S. S.

Top of Casing: ft. below ground

PUMPING TEST

Date:
Pumping Rate: 30.0 Imp. gallons/minute
Water level before pumping: 6.0 ft. below ground
Pumping level at end of test: 25.0 ft. below ground

Test duration: hours, 30 minutes
Water temperature: ?? degrees F

REMARKS

MPWI-ER-WHITESHELL-FALCON LAKE CAMPGROUND AREA 2-UNKNONW WELL. FALCON LAKE, GROUP USE CAMPGROUND, WELL INSTALLED AT TEST HOLE F-9 (1973) SITE. FIELD ANALYSIS

LOCATION: 21-8-16E

Well_PID: 31089
Owner: PARKS BRANCH
Driller: M & M Drilling Rivers Ltd.
Well Name: WELL NO 2
Well Use: PRODUCTION
Water Use: Domestic
UTMX: 763255.615
UTMY: 5508588.69
Accuracy XY: UNKNOWN
UTMZ:
Accuracy Z:
Date Completed: 1977 Jul 15

WELL LOG

From (ft.)	To (ft.)	Log
0	4.0	CLAY LIGHT BROWN
4.0	6.0	SANDY CLAY
6.0	7.0	CLAY- LIGHT BROWN
7.0	9.0	CLAYEY SAND
9.0	10.0	CLAY
10.0	24.0	SAND- BROWN TO GREY, MEDIUM
24.0	25.0	SAND AND GRAVEL- COARSE ROCK- GRANITE AT 25 FEET

WELL CONSTRUCTION

From (ft.)	To (ft.)	Casing Type	Inside Dia.(in)	Outside Dia.(in)	Slot Size(in)	Type	Material
0	20.0	casing	5.00			INSERT	BLACK
20.0	25.0	perforations	4.90		0.018	WIRE WOUND	S. S.
13.0	25.0	gravel pack	5.00			NO. 10-30	SILICA

S.

Top of Casing: ft. below ground

PUMPING TEST

Date:

Pumping Rate: 50.0 Imp. gallons/minute
Water level before pumping: 10.0 ft. below ground
Pumping level at end of test: 15.0 ft. below ground
Test duration: hours, 50 minutes
Water temperature: ?? degrees F

REMARKS

MPWI-ER-WHITESHELL-FALCON LAKE STAFF-UNKNOWN WELL. FALCON LAKE, STAFF
TRAILER AREA, 86 FT W OF PUMPHOUSE, EC=345 MM, NA_{CL}= <12 PPM, H=12
GPG, FE=TRACE

Test Hole Logs

J. R. Cousin Consultants Ltd.
TEST HOLE LOGS

SYMBOL INDEX



GW. : Well graded gravels and gravel sand mixtures, little or no fines



GP. : Poorly graded gravels, gravel - sand mixtures, little or no fines



GM. : Silty gravels, gravel-sand-silt mixtures



GC. : Clayey gravels, gravel-sand-clay mixtures



SW. : Well graded sands, gravelly sands, little or no fines



SP. : Poorly graded sands, or gravelly sands, little or no fines



SM. : Silty sands, sand-silt mixtures



SC. : Clayey sands, sand-clay mixtures



ML. : Inorganic silts and very fine sands, rock flour, silty or clayey fine sands, or clayey silts with slight plasticity



CL. : Inorganic clays of low plasticity, gravelly clays, sandy or silty clays, lean clays



OL. : Organic silts and organic silty clays of low plasticity



CI. : Inorganic clays of medium or intermediate plasticity



MH. : Inorganic silts, fine sandy or silty soils



CH. : Inorganic clays of high plasticity, fat clays



OH. : Organic clays of medium to high plasticity, organic silts



Pt. : Peat, humus, swamp soils with high organic contents



TOPSOIL

The soil logs are based upon objective data available to us at the time of forming our opinions. The soil logs indicate site specific soil characteristics and must not be generalized over larger areas due to the limited number of test holes as compared to that of an unlimited number of test holes. Every effort is made to evaluate the information by methods generally recognized. The soil logs represent our opinions. J. R. Cousin Consultants Ltd. cannot be responsible for actual site conditions proved to be materially at variance from our analysis or from the data generalization over untested areas.

J. R. Cousin Consultants Ltd.

TEST HOLE LOG SHEET

LOCATION : 5504741.44 N
327437.85 E

PROJECT : South Whiteshell Truck Haul Lagoon

DATE : Nov 9, 2011

ELEVATION : 335.294 m

TEST HOLE # 1

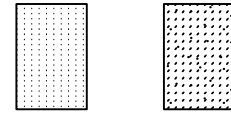
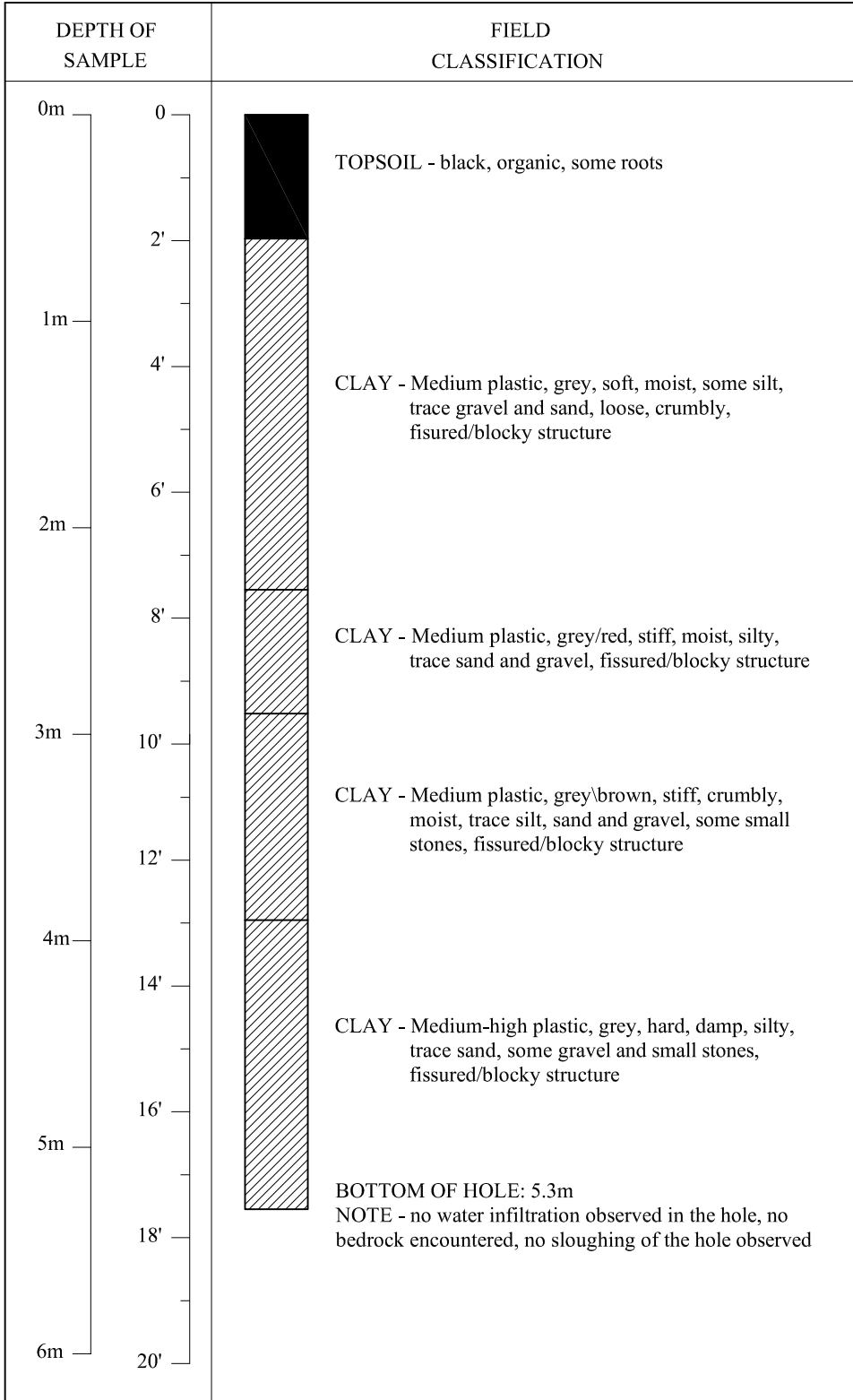

GW

GP



GM

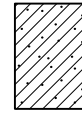

GC



SW



SP

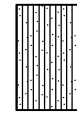

SM



SC

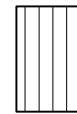

ML



CL

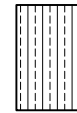

OL



CI



MH



CH



OH



PT



Topsoil

The soil logs are based upon objective data available to us at the time of forming our opinions. The soil logs indicate site specific soil characteristics and must not be generalized over larger areas due to the limited number of test holes as compared to that of an unlimited number of test holes. Every effort is made to evaluate the information by methods generally recognized. The soil represent our opinions. J.R. Cousin Consultants Ltd. cannot be responsible for actual site conditions proved to be materially at variance from our analysis or from the data generalization over untested areas.

J. R. Cousin Consultants Ltd.

TEST HOLE LOG SHEET

LOCATION : 5504631.77 N
327335.95 E

PROJECT : South Whiteshell Truck Haul Lagoon

DATE : Nov 9, 2011

ELEVATION : 335.193 m

TEST HOLE # 2

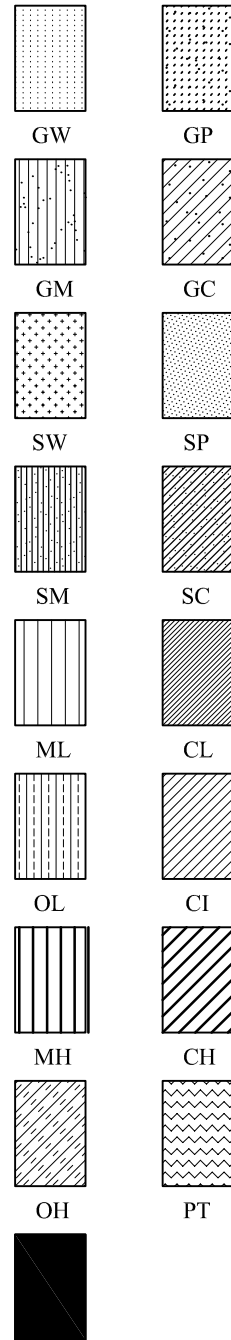
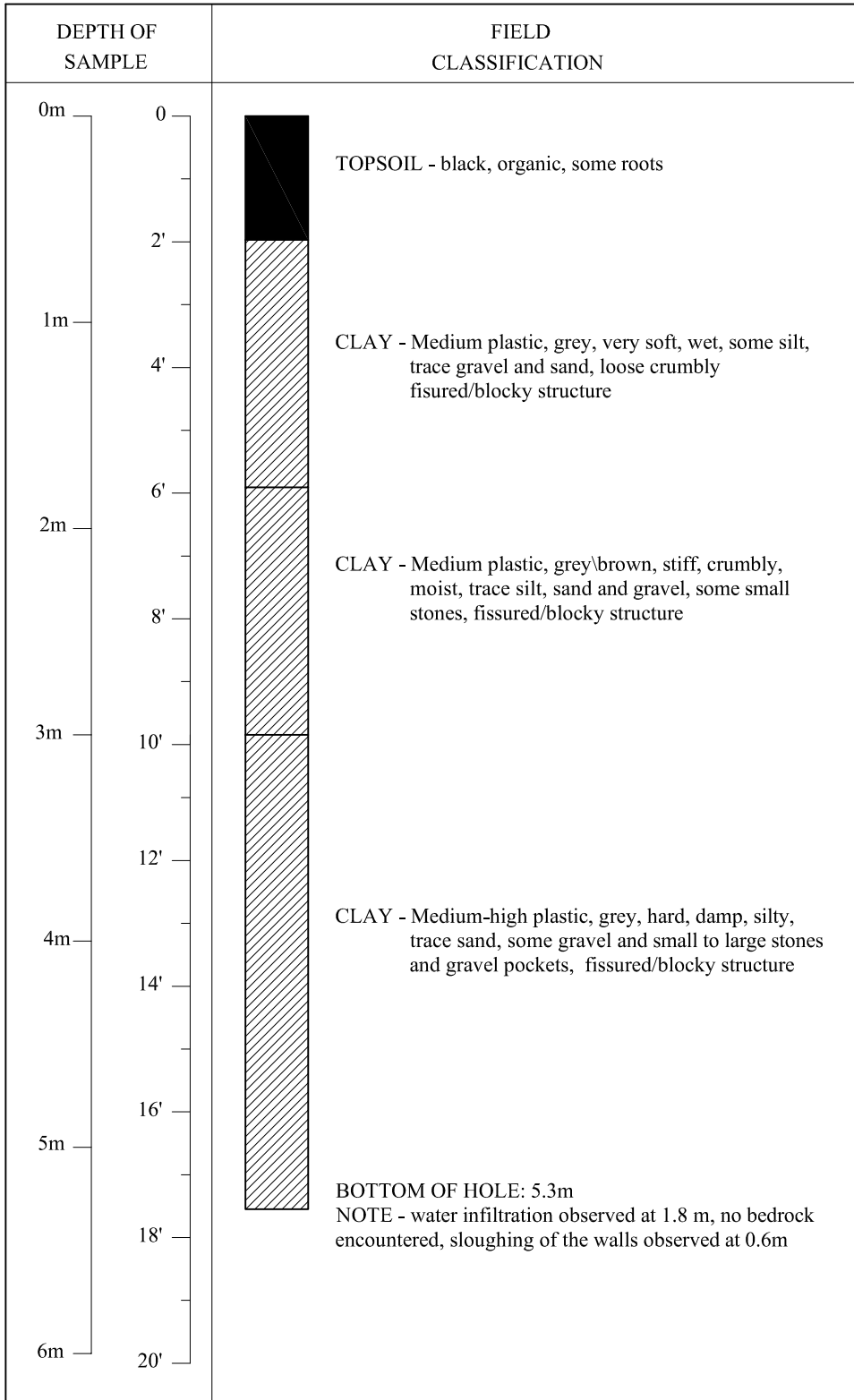

The soil logs are based upon objective data available to us at the time of forming our opinions. The soil logs indicate site specific soil characteristics and must not be generalized over larger areas due to the limited number of test holes as compared to that of a unlimited number of test holes. Every effort is made to evaluate the information by methods generally recognized. The soil represent our opinions. J.R. Cousin Consultants Ltd. cannot be responsible for actual site conditions proved to be materially at variance from our analysis or from the data generalization over untested areas.

J. R. Cousin Consultants Ltd.

TEST HOLE LOG SHEET

LOCATION : 5504597.04 N
327316.47 E

PROJECT : South Whiteshell Truck Haul Lagoon

DATE : Nov 9, 2011

ELEVATION : 335.176 m

TEST HOLE # 3

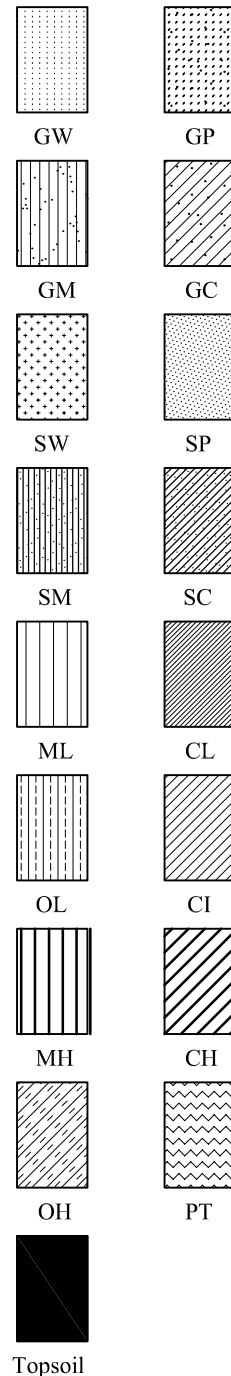
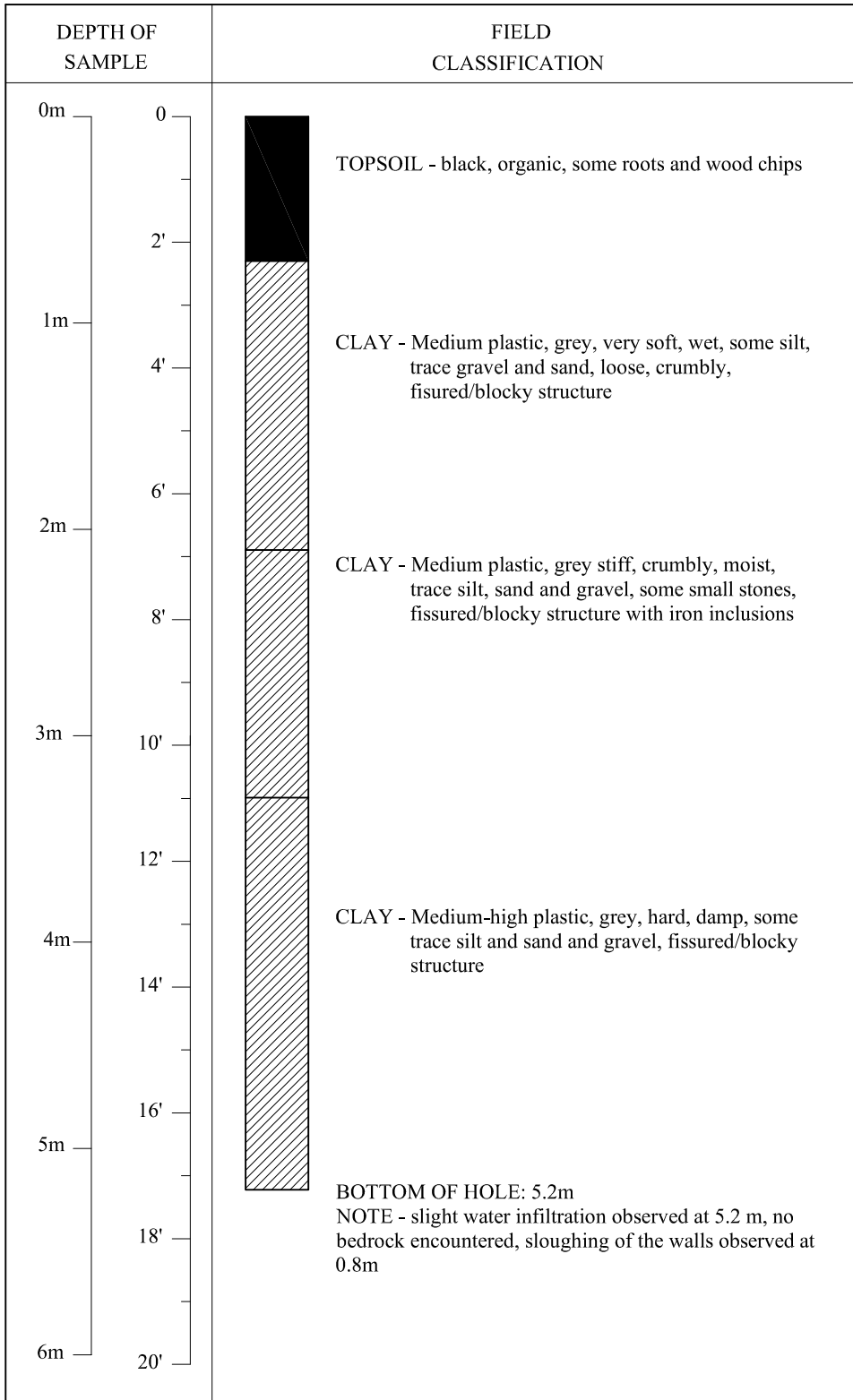

The soil logs are based upon objective data available to us at the time of forming our opinions. The soil logs indicate site specific soil characteristics and must not be generalized over larger areas due to the limited number of test holes as compared to that of a unlimited number of test holes. Every effort is made to evaluate the information by methods generally recognized. The soil represent our opinions. J.R. Cousin Consultants Ltd. cannot be responsible for actual site conditions proved to be materially at variance from our analysis or from the data generalization over untested areas.

J. R. Cousin Consultants Ltd.

TEST HOLE LOG SHEET

LOCATION : 5504489.77 N
327399.03 E

PROJECT : South Whiteshell Truck Haul Lagoon

DATE : Nov 9, 2011

ELEVATION : 334.789 m

TEST HOLE # 4

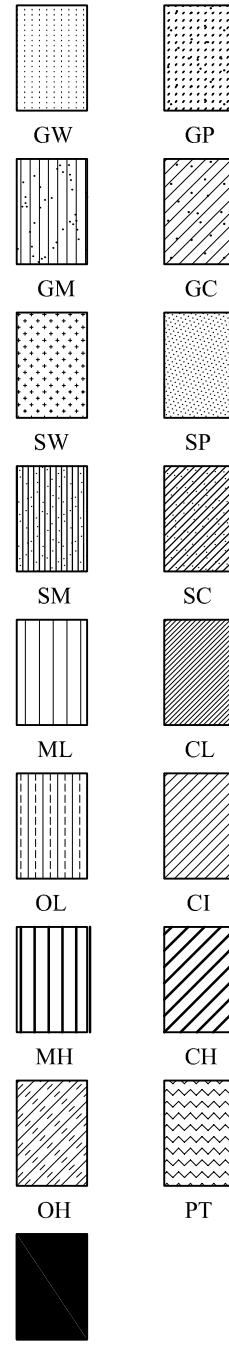
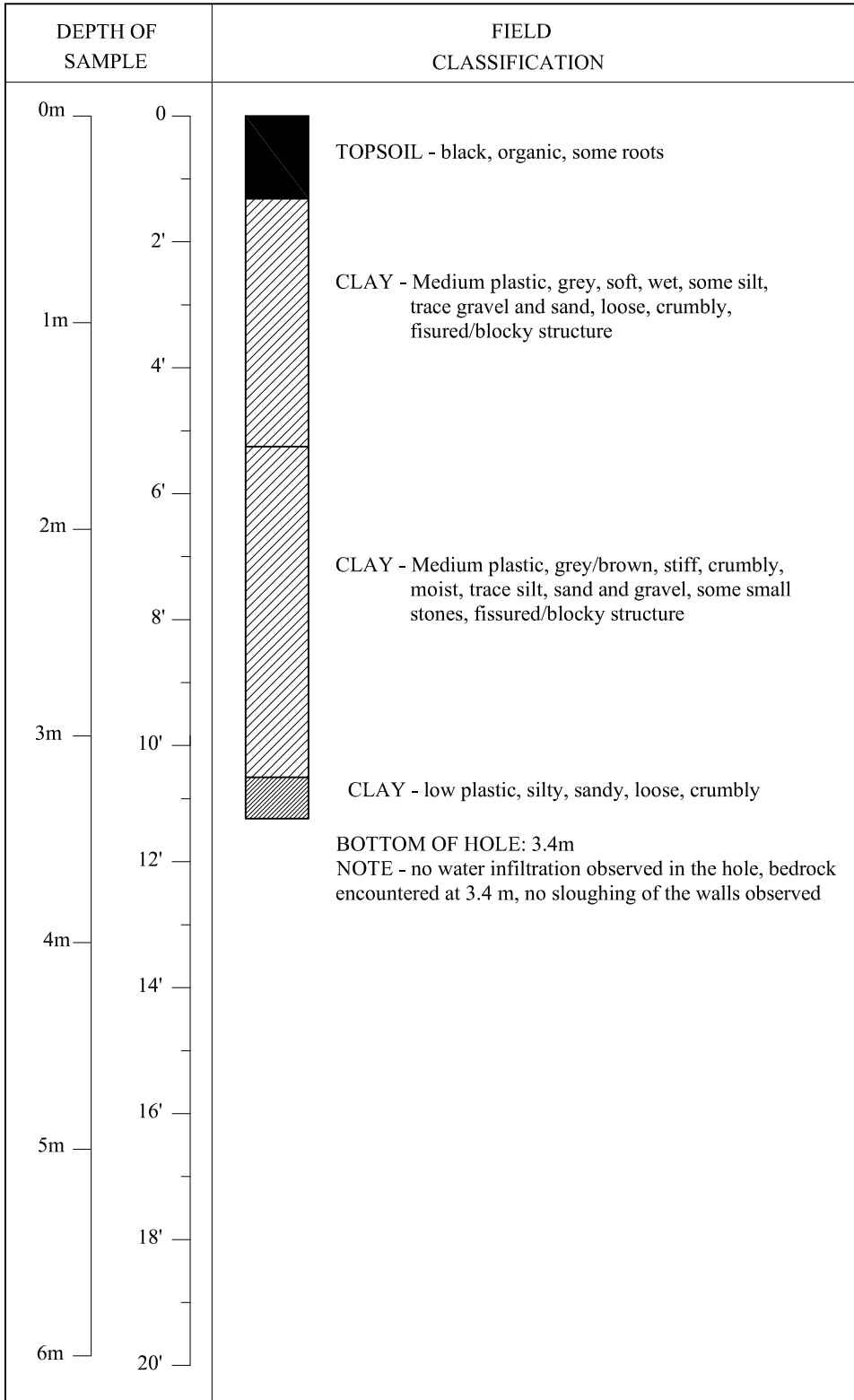

Topsoil

The soil logs are based upon objective data available to us at the time of forming our opinions. The soil logs indicate site specific soil characteristics and must not be generalized over larger areas due to the limited number of test holes as compared to that of an unlimited number of test holes. Every effort is made to evaluate the information by methods generally recognized. The soil represent our opinions. J.R. Cousin Consultants Ltd. cannot be responsible for actual site conditions proved to be materially at variance from our analysis or from the data generalization over untested areas.

J. R. Cousin Consultants Ltd.

TEST HOLE LOG SHEET

LOCATION : 5504594.11 N
327455.12 E

PROJECT : South Whiteshell Truck Haul Lagoon

DATE : Nov 9, 2011

ELEVATION : 335.082 m

TEST HOLE # 5

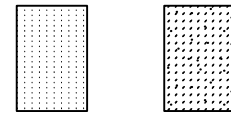
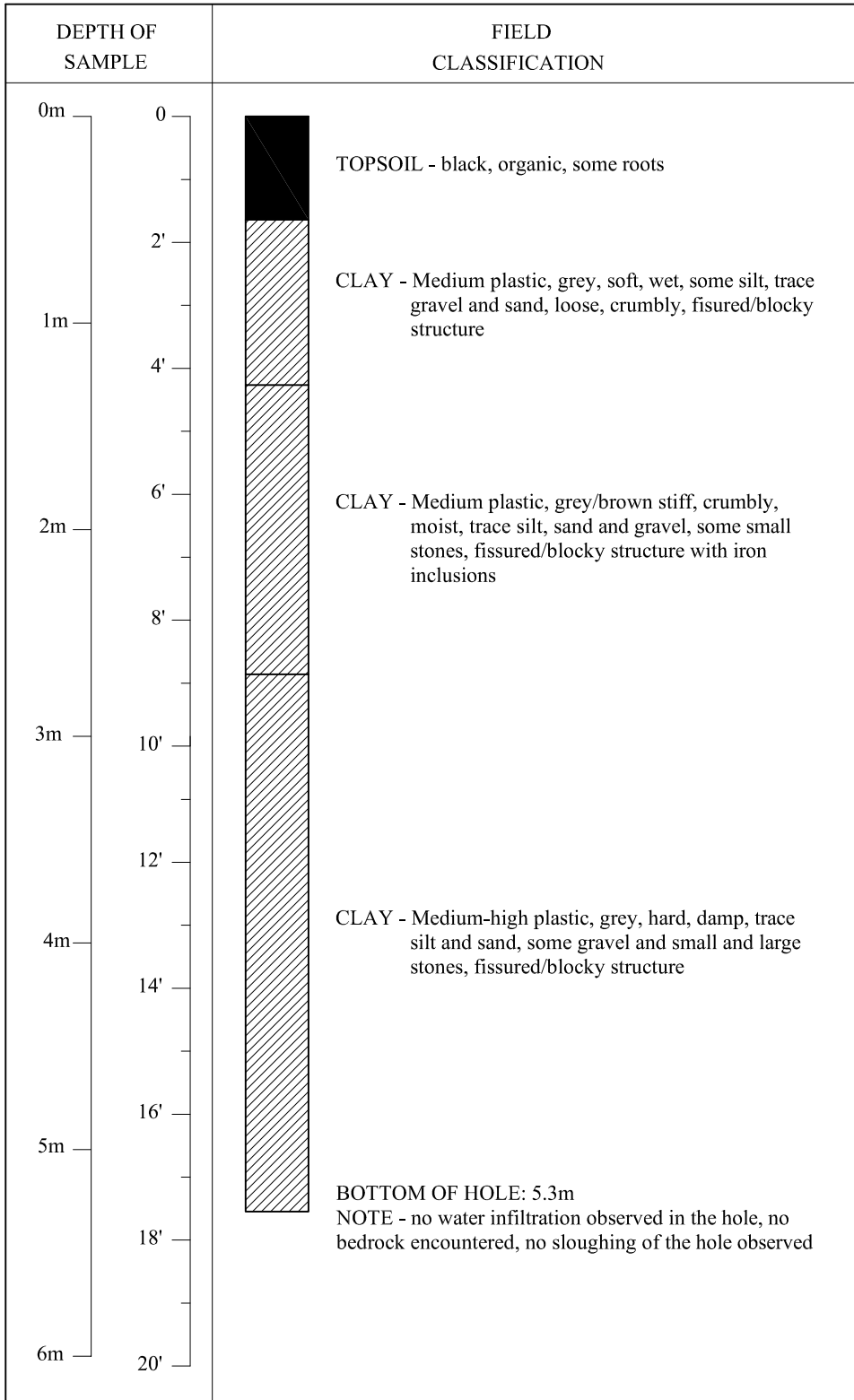

GW

GP



GM



GC



SW



SP

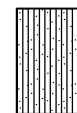

SM



SC

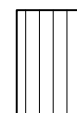

ML



CL

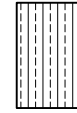

OL



CI

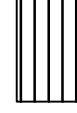

MH



CH



OH



PT



Topsoil

The soil logs are based upon objective data available to us at the time of forming our opinions. The soil logs indicate site specific soil characteristics and must not be generalized over larger areas due to the limited number of test holes as compared to that of an unlimited number of test holes. Every effort is made to evaluate the information by methods generally recognized. The soil represent our opinions. J.R. Cousin Consultants Ltd. cannot be responsible for actual site conditions proved to be materially at variance from our analysis or from the data generalization over untested areas.

J. R. Cousin Consultants Ltd.

TEST HOLE LOG SHEET

LOCATION : 5504666.82 N
327515.76 E

PROJECT : South Whiteshell Truck Haul Lagoon

DATE : Nov 9, 2011

ELEVATION : 335.366 m

TEST HOLE # 6

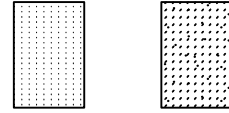
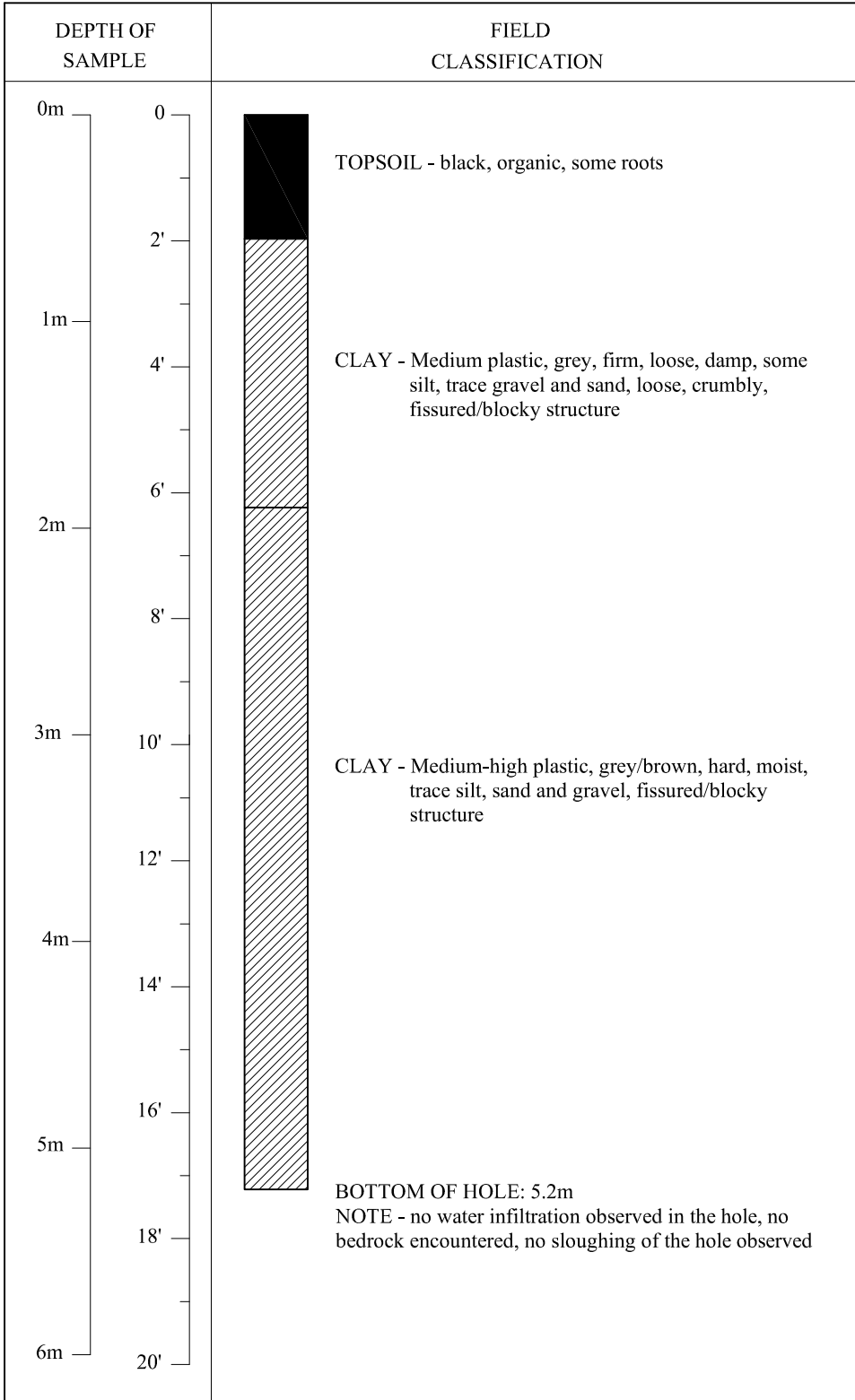

GW

GP



GM



GC



SW



SP

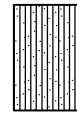

SM



SC

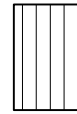

ML



CL



OL



CI

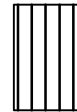

MH



CH



OH



PT



Topsoil

The soil logs are based upon objective data available to us at the time of forming our opinions. The soil logs indicate site specific soil characteristics and must not be generalized over larger areas due to the limited number of test holes as compared to that of an unlimited number of test holes. Every effort is made to evaluate the information by methods generally recognized. The soil represent our opinions. J.R. Cousin Consultants Ltd. cannot be responsible for actual site conditions proved to be materially at variance from our analysis or from the data generalization over untested areas.

J. R. Cousin Consultants Ltd.

TEST HOLE LOG SHEET

LOCATION : 5504193.18 N
326437.29 E

PROJECT : South Whiteshell Truck Haul Lagoon

DATE : Nov 9, 2011

ELEVATION : 333.19 m

TEST HOLE # 7

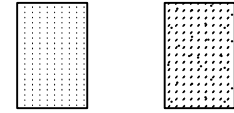
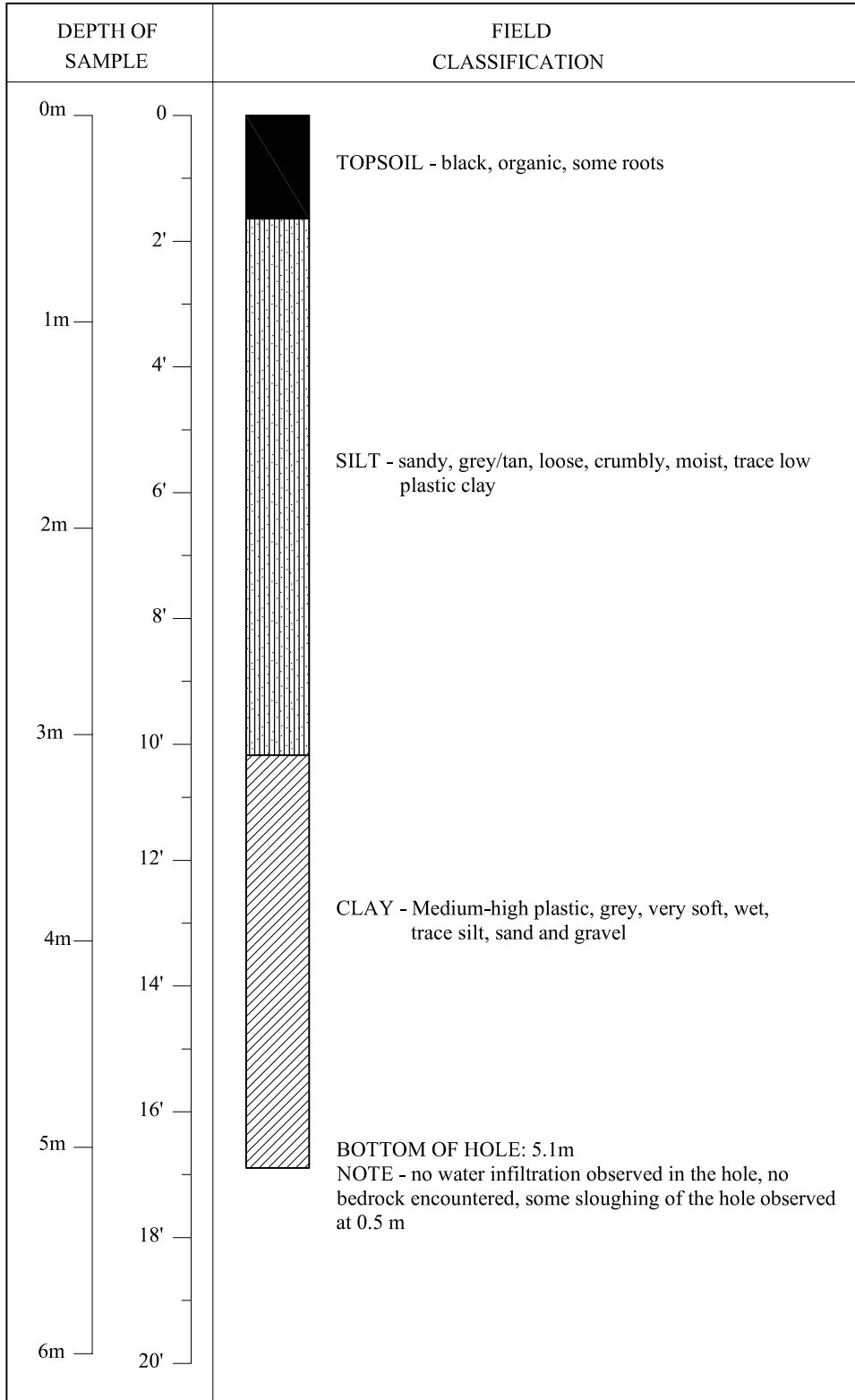

GW

GP

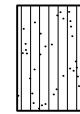

GM



GC

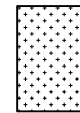

SW



SP

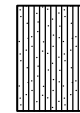

SM



SC

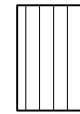

ML



CL



OL



CI



MH



CH



OH



PT



Topsoil

The soil logs are based upon objective data available to us at the time of forming our opinions. The soil logs indicate site specific soil characteristics and must not be generalized over larger areas due to the limited number of test holes as compared to that of a unlimited number of test holes. Every effort is made to evaluate the information by methods generally recognized. The soil represent our opinions. J.R. Cousin Consultants Ltd. cannot be responsible for actual site conditions proved to be materially at variance from our analysis or from the data generalization over untested areas.

J. R. Cousin Consultants Ltd.

TEST HOLE LOG SHEET

LOCATION : NOT RECORDED

DATE : Nov 9, 2011

ELEVATION : NOT RECORDED

PROJECT : South Whiteshell Truck Haul Lagoon

TEST HOLE # 8

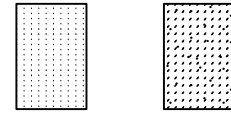
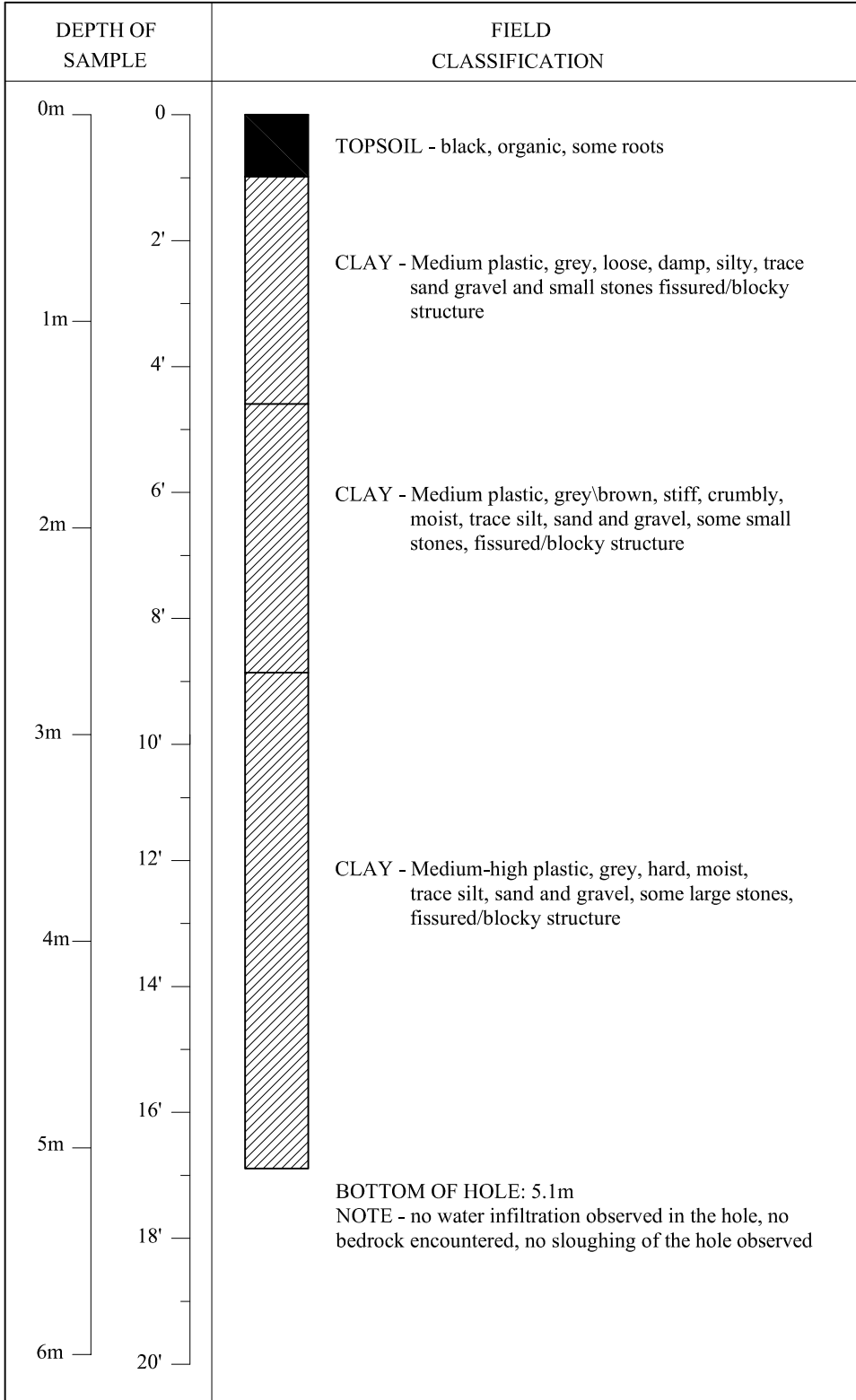

GW

GP



GM

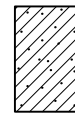

GC



SW

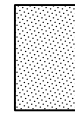

SP



SM



SC

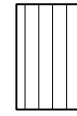

ML



CL

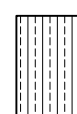

OL



CI



MH



CH



OH



PT



Topsoil

The soil logs are based upon objective data available to us at the time of forming our opinions. The soil logs indicate site specific soil characteristics and must not be generalized over larger areas due to the limited number of test holes as compared to that of a unlimited number of test holes. Every effort is made to evaluate the information by methods generally recognized. The soil represent our opinions. J.R. Cousin Consultants Ltd. cannot be responsible for actual site conditions proved to be materially at variance from our analysis or from the data generalization over untested areas.

J. R. Cousin Consultants Ltd.

TEST HOLE LOG SHEET

LOCATION : 5504185.72 N
326436.84 E

PROJECT : South Whiteshell Truck Haul Lagoon

DATE : Nov 9, 2011

ELEVATION : 333.412 m

TEST HOLE # 9

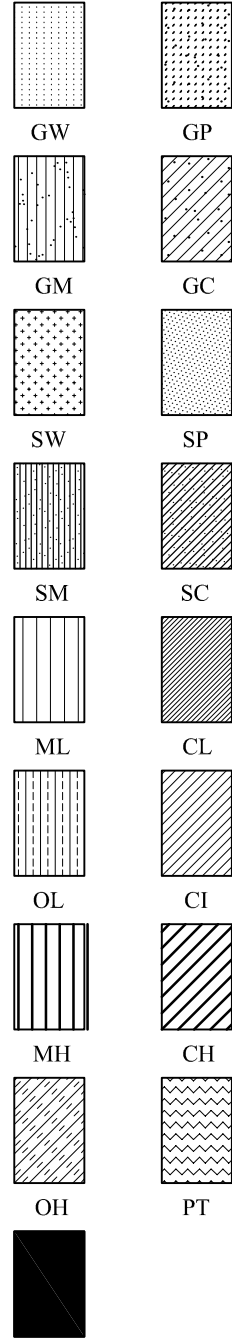
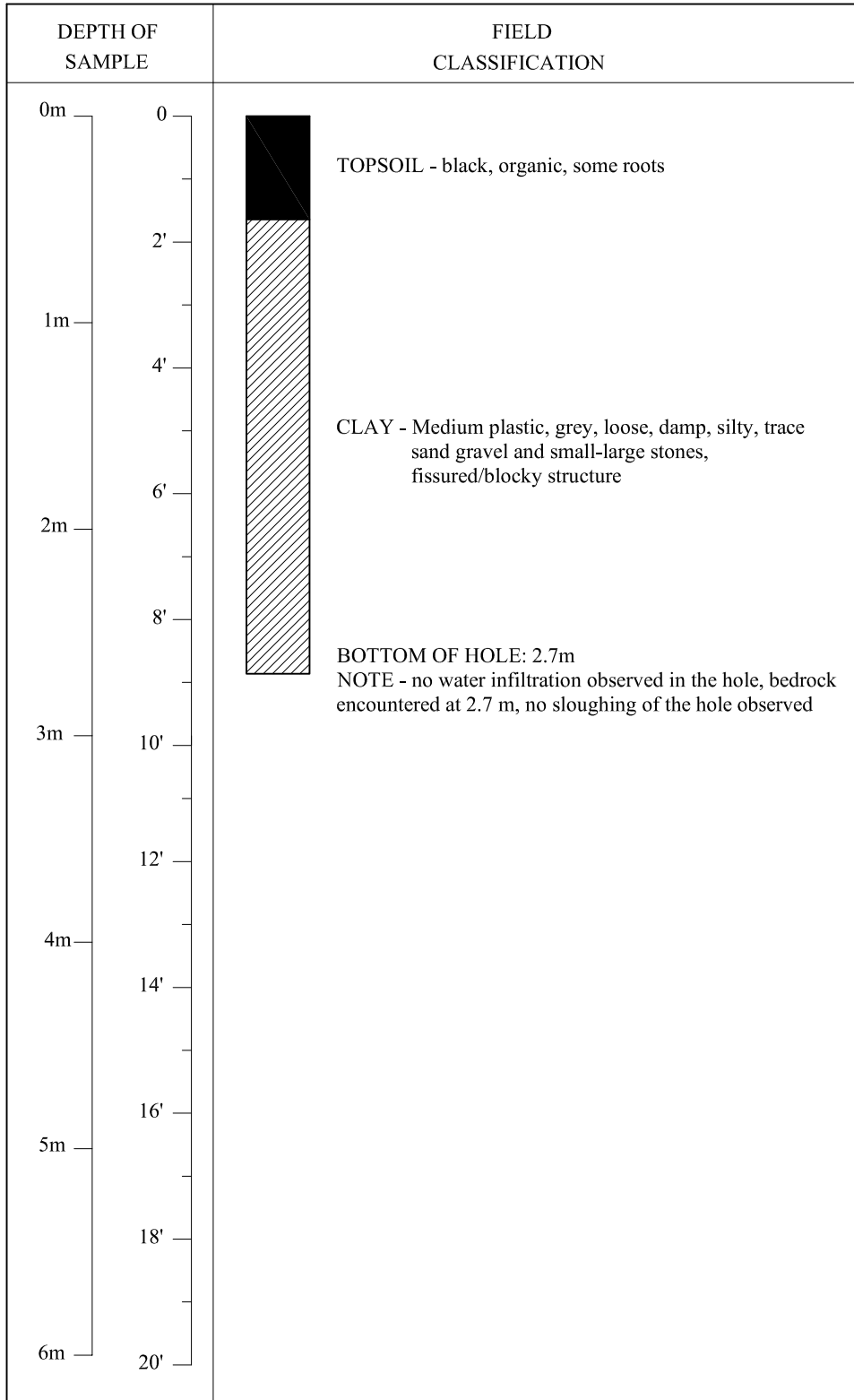

The soil logs are based upon objective data available to us at the time of forming our opinions. The soil logs indicate site specific soil characteristics and must not be generalized over larger areas due to the limited number of test holes as compared to that of an unlimited number of test holes. Every effort is made to evaluate the information by methods generally recognized. The soil represent our opinions. J.R. Cousin Consultants Ltd. cannot be responsible for actual site conditions proved to be materially at variance from our analysis or from the data generalization over untested areas.

The National Testing Laboratories Limited Test Results, dated December 16, 2011



**THE
NATIONAL
TESTING
LABORATORIES
LIMITED**
Established in 1923

199 Henlow Bay
Winnipeg, MB R3Y 1G4
Phone (204) 488-6999
Fax (204) 488-6947
Email info@nationaltestlabs.com
www.nationaltestlabs.com

J.R. Cousin Consultants Ltd.
91 A Scurfield Blvd.
Winnipeg, Manitoba
R3Y 1G4

Attention: Brett McCormac

December 16, 2011

Project: South Whiteshell
Truck Haul Lagoon

Soil samples were submitted to our laboratory on November 15, 2011. The following tests were conducted on selected soil samples:

- water content (ASTM D2216)
- particle size analysis (ASTM D422)
- liquid limit, plastic limit, and plasticity index (ASTM D4318)
- soil classification (ASTM D2487)
- hydraulic conductivity (ASTM D5084)
- visual classification

The test results for the soil samples are summarized in the following tables and in the attached particle size analysis and hydraulic conductivity reports.

An assessment of the bagged soil samples was conducted to determine whether the soil represented by the bagged samples could be used in-situ as a lagoon liner and would obtain a hydraulic conductivity of less than 1.0×10^{-7} cm/sec without being reworked, and when re-moulded and re-compacted.

Based upon previous testing conducted in our laboratory, homogeneous soil samples with a plasticity index greater than 25 and a clay content greater than 50% will typically have a hydraulic conductivity of 1.0×10^{-7} cm/sec or less. All of the bagged samples satisfied these criteria and are considered suitable for use as a lagoon liner. Our comments regarding the potential use of the material as a liner are based upon the soil being homogeneous with no preferential flow paths. It should be noted that estimating the hydraulic conductivity of a soil based upon classification test results (plasticity index and particle size analysis) alone might be misleading if the soil contains layers of sand, silt, or organic material.

The hydraulic conductivity result for sample TH1 at 0.6 – 2.3 m is less than the specified maximum hydraulic conductivity value of 1.0×10^{-7} cm/s for lagoon liners. It should be noted that the sample consisted of a disturbed bagged sample and was remoulded in our laboratory prior to testing for hydraulic conductivity.

We appreciate the opportunity to assist you in this project. Please call if you have any questions regarding this report.

Aron Piamsalee, B.Sc., EIT
Geotechnical Project Manager

**SUMMARY OF WATER CONTENT, PARTICLE SIZE, ATTERBERG LIMITS, SOIL CLASSIFICATION TEST DATA
SOUTH WHITESHELL TRUCK HAUL LAGOON**

Testhole	Depth (m)	Visual Classification	Water Content (%)	Gravel (%) 75 to 4.75 mm	Sand (%)			Silt (%) <0.075 to 0.005 mm	Clay (%) <0.005 mm	Liquid Limit	Plastic Limit	Plasticity Index	Soil Classification ASTM D2487	Potential use as a lagoon liner when remoulded and re-compacted	Potential use as a lagoon liner without being reworked
					Coarse <4.75 to 2.0 mm	Medium <2.0 to 0.425 mm	Fine <0.425 to 0.075 mm								
TH1	0.6 - 2.3	brown, firm, moist, medium plasticity clay, silty, trace gravel and sand	24.4	1.1	0.5	1.9	5.2	24.5	66.8	49	19	30	CL-Lean Clay	yes	yes
TH1	2.9 - 3.9	brown, firm, moist, high plasticity clay, silty, trace gravel and sand	22.1	1.0	0.6	2.1	4.8	25.4	66.1	50	11	39	CH-Fat Clay	yes	yes
TH1	3.9 - 5.3	brown, stiff, moist, medium plasticity clay, silty, trace gravel and sand	25.8	0.5	0.7	1.4	4.8	24.8	67.8	47	18	29	CL-Lean Clay	yes	yes
TH6	1.9 - 5.2	brown, stiff, moist, high plasticity clay, some silt, trace gravel and sand	25.5	2.6	0.9	2.1	4.4	19.7	70.3	58	19	39	CH-Fat Clay	yes	yes
TH8	0.3 - 1.9	brown, firm, moist, medium plasticity clay, silty, trace gravel and sand	20.4	0.5	0.9	2.2	6.3	25.1	65.0	49	17	32	CL-Lean Clay	yes	yes
TH8	2.7 - 5.1	brown, stiff, moist, high plasticity clay, silty, trace gravel and sand	28.5	1.4	0.8	2.3	3.1	25.5	66.9	55	19	36	CH-Fat Clay	yes	yes

Notes:

1. A high speed stirring device was used for 1 minute to disperse the test samples for particle size analysis.
2. Atterberg limits conducted in accordance with ASTM D4318 Method B (one-point liquid limit).
3. The soil samples were air-dried during sample preparation for Atterberg limits and particle size analysis.

**TABLE 2
HYDRAULIC CONDUCTIVITY SUMMARY
SOUTH WHITESHELL TRUCK HAUL LAGOON**

Testhole	Depth (m)	Hydraulic Conductivity, "k ₂₀ "
TH1	0.6 – 2.3	7.7 x 10 ⁻⁹ cm/s

Note: Sample was lab-remoulded prior to testing.



PARTICLE SIZE ANALYSIS ASTM D422

J.R. Cousin Consultants Ltd.
91A Scurfield Blvd.
Winnipeg, Manitoba
R3Y 1G4

PROJECT: South Whiteshell Truck Haul Lagoon

Attention: Brett McCormac

PROJECT NO.: JRC-1112

SAMPLED BY: Client

DATE RECEIVED: November 10, 2011

SAMPLE ID: TH1 at 0.6-2.3 m

TESTED BY: Larry Presado

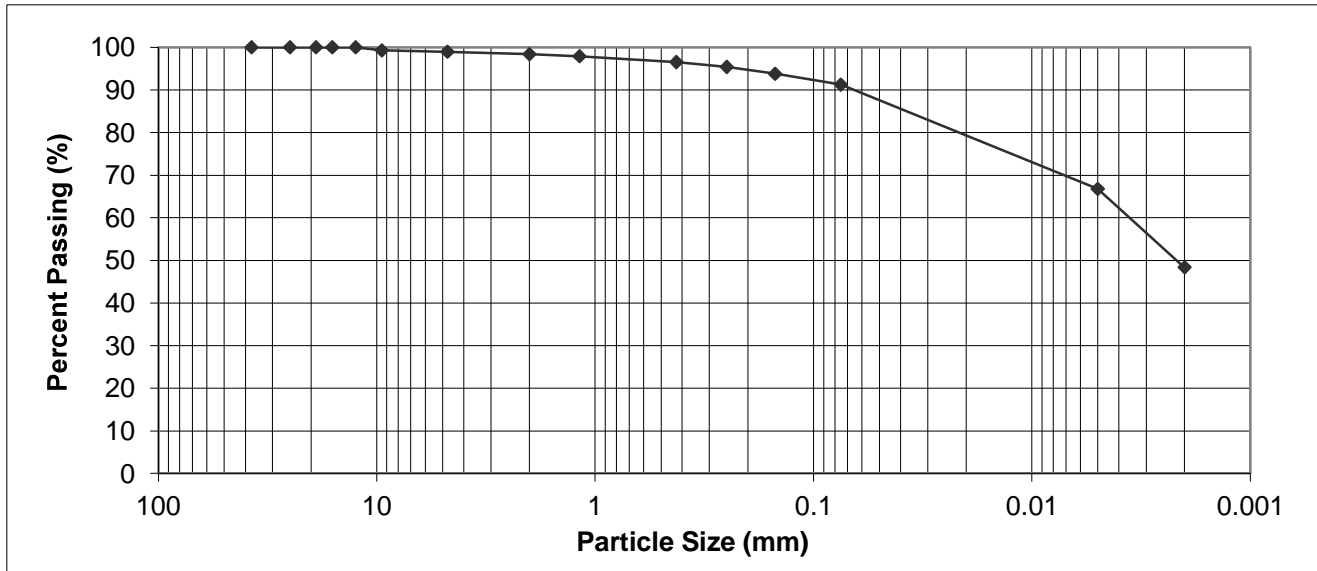

PARTICLE SIZE	PERCENT PASSING	PARTICLE SIZE	PERCENT PASSING
37.50 mm	100.0	1.18 mm	97.9
25.00 mm	100.0	0.425 mm	96.5
19.00 mm	100.0	0.250 mm	95.4
16.00 mm	100.0	0.150 mm	93.8
12.50 mm	100.0	0.075 mm	91.3
9.50 mm	99.3	0.005 mm	66.8
4.75 mm	98.9	0.002 mm	48.4
2.00 mm	98.4	0.001 mm	NT

Gravel, % 75 to 4.75 mm	Sand, %			Silt, % <0.075 to 0.005 mm	Clay, % <0.005 mm	Colloids, % < 0.001 mm
	Coarse <4.75 to 2.0 mm	Medium <2.0 to 0.425 mm	Fine <0.425 to 0.075 mm			
1.1	0.5	1.9	5.2	24.5	66.8	NT

Note: Colloids content not tested

December 9, 2011

REVIEWED BY: Farouk Fourar, EIT



PARTICLE SIZE ANALYSIS ASTM D422

J.R. Cousin Consultants Ltd.
91A Scurfield Blvd.
Winnipeg, Manitoba
R3Y 1G4

PROJECT: South Whiteshell Truck Haul Lagoon

Attention: Brett McCormac

PROJECT NO.: JRC-1112

SAMPLED BY: Client
SAMPLE ID: TH1 at 2.9-3.9 m

DATE RECEIVED: November 10, 2011
TESTED BY: Sothea Bun

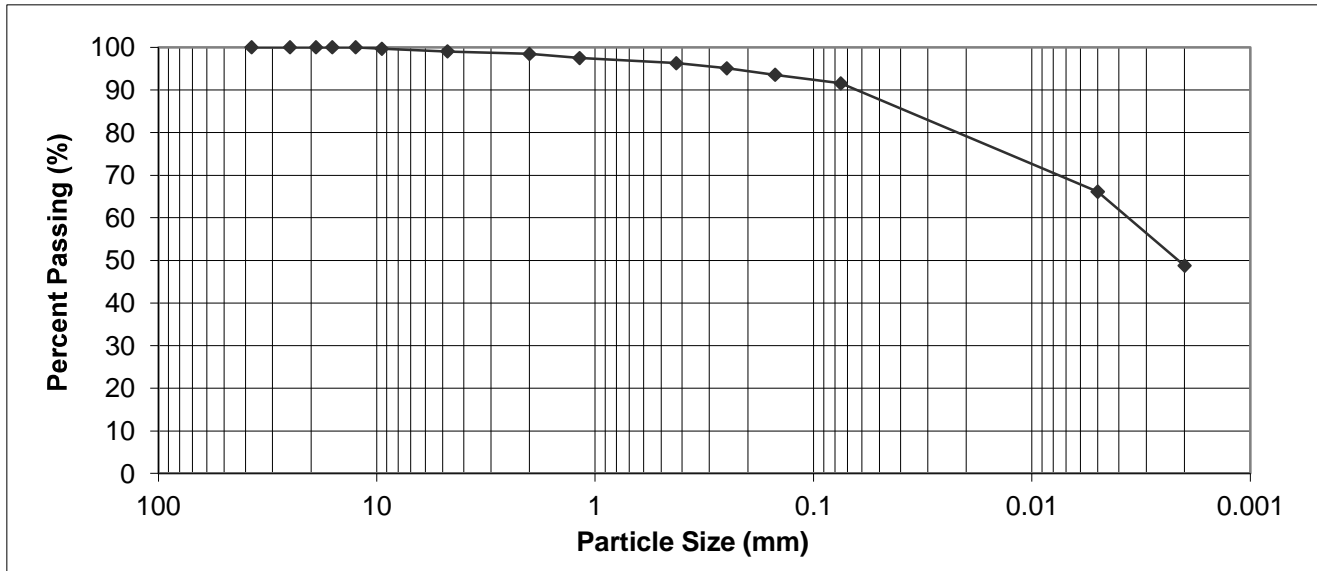

PARTICLE SIZE	PERCENT PASSING	PARTICLE SIZE	PERCENT PASSING
37.50 mm	100.0	1.18 mm	97.5
25.00 mm	100.0	0.425 mm	96.3
19.00 mm	100.0	0.250 mm	95.1
16.00 mm	100.0	0.150 mm	93.5
12.50 mm	100.0	0.075 mm	91.5
9.50 mm	99.7	0.005 mm	66.1
4.75 mm	99.0	0.002 mm	48.7
2.00 mm	98.4	0.001 mm	NT

Gravel, % 75 to 4.75 mm	Sand, %			Silt, % <0.075 to 0.005 mm	Clay, % <0.005 mm	Colloids, % < 0.001 mm
	Coarse <4.75 to 2.0 mm	Medium <2.0 to 0.425 mm	Fine <0.425 to 0.075 mm			
1.0	0.6	2.1	4.8	25.4	66.1	NT

Note: Colloids content not tested

December 9, 2011

REVIEWED BY: Farouk Fourar, EIT



PARTICLE SIZE ANALYSIS ASTM D422

J.R. Cousin Consultants Ltd.
91A Scurfield Blvd.
Winnipeg, Manitoba
R3Y 1G4

PROJECT: South Whiteshell Truck Haul Lagoon

Attention: Brett McCormac

PROJECT NO.: JRC-1112

SAMPLED BY: Client

DATE RECEIVED: November 10, 2011

SAMPLE ID: TH1 at 3.9-5.3 m

TESTED BY: Sothea Bun

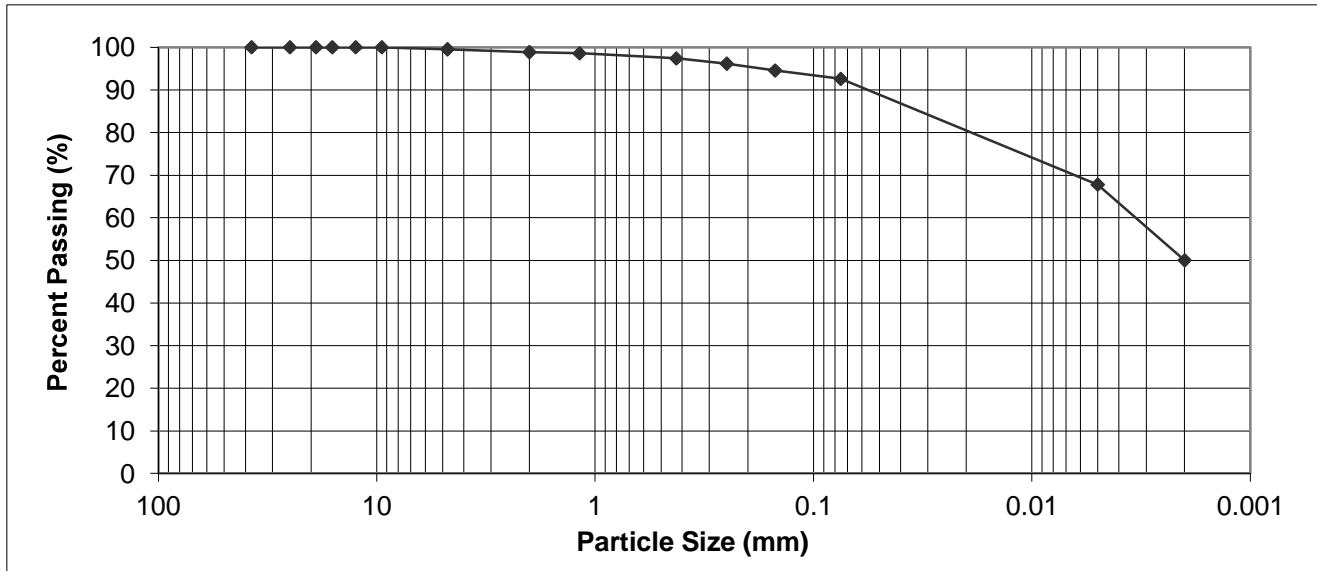

PARTICLE SIZE	PERCENT PASSING	PARTICLE SIZE	PERCENT PASSING
37.50 mm	100.0	1.18 mm	98.6
25.00 mm	100.0	0.425 mm	97.4
19.00 mm	100.0	0.250 mm	96.1
16.00 mm	100.0	0.150 mm	94.6
12.50 mm	100.0	0.075 mm	92.6
9.50 mm	100.0	0.005 mm	67.8
4.75 mm	99.5	0.002 mm	50.0
2.00 mm	98.8	0.001 mm	NT

Gravel, % 75 to 4.75 mm	Sand, %			Silt, % <0.075 to 0.005 mm	Clay, % <0.005 mm	Colloids, % < 0.001 mm
	Coarse <4.75 to 2.0 mm	Medium <2.0 to 0.425 mm	Fine <0.425 to 0.075 mm			
0.5	0.7	1.4	4.8	24.8	67.8	NT

Note: Colloids content not tested

December 9, 2011

REVIEWED BY: Farouk Fourar, EIT



PARTICLE SIZE ANALYSIS ASTM D422

J.R. Cousin Consultants Ltd.
91A Scurfield Blvd.
Winnipeg, Manitoba
R3Y 1G4

PROJECT: South Whiteshell Truck Haul Lagoon

Attention: Brett McCormac

PROJECT NO.: JRC-1112

SAMPLED BY: Client

DATE RECEIVED: November 10, 2011

SAMPLE ID: TH6 at 1.9-5.2 m

TESTED BY: Sothea Bun

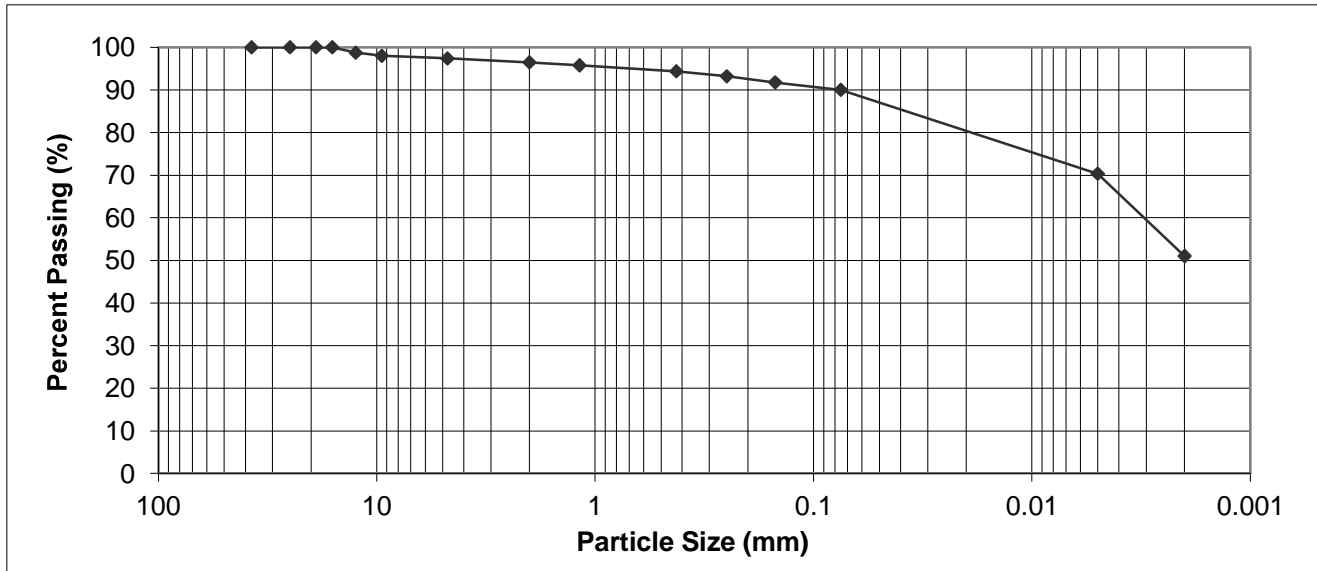

PARTICLE SIZE	PERCENT PASSING	PARTICLE SIZE	PERCENT PASSING
37.50 mm	100.0	1.18 mm	95.8
25.00 mm	100.0	0.425 mm	94.4
19.00 mm	100.0	0.250 mm	93.2
16.00 mm	100.0	0.150 mm	91.8
12.50 mm	98.7	0.075 mm	90.0
9.50 mm	98.0	0.005 mm	70.3
4.75 mm	97.4	0.002 mm	51.0
2.00 mm	96.5	0.001 mm	NT

Gravel, % 75 to 4.75 mm	Sand, %			Silt, % <0.075 to 0.005 mm	Clay, % <0.005 mm	Colloids, % < 0.001 mm
	Coarse <4.75 to 2.0 mm	Medium <2.0 to 0.425 mm	Fine <0.425 to 0.075 mm			
2.6	0.9	2.1	4.4	19.7	70.3	NT

Note: Colloids content not tested

December 9, 2011

REVIEWED BY: Farouk Fourar, EIT



PARTICLE SIZE ANALYSIS ASTM D422

J.R. Cousin Consultants Ltd.
91A Scurfield Blvd.
Winnipeg, Manitoba
R3Y 1G4

PROJECT: South Whiteshell Truck Haul Lagoon

Attention: Brett McCormac

PROJECT NO.: JRC-1112

SAMPLED BY: Client
SAMPLE ID: TH8 at 0.3-1.9 m

DATE RECEIVED: November 10, 2011
TESTED BY: Sothea Bun

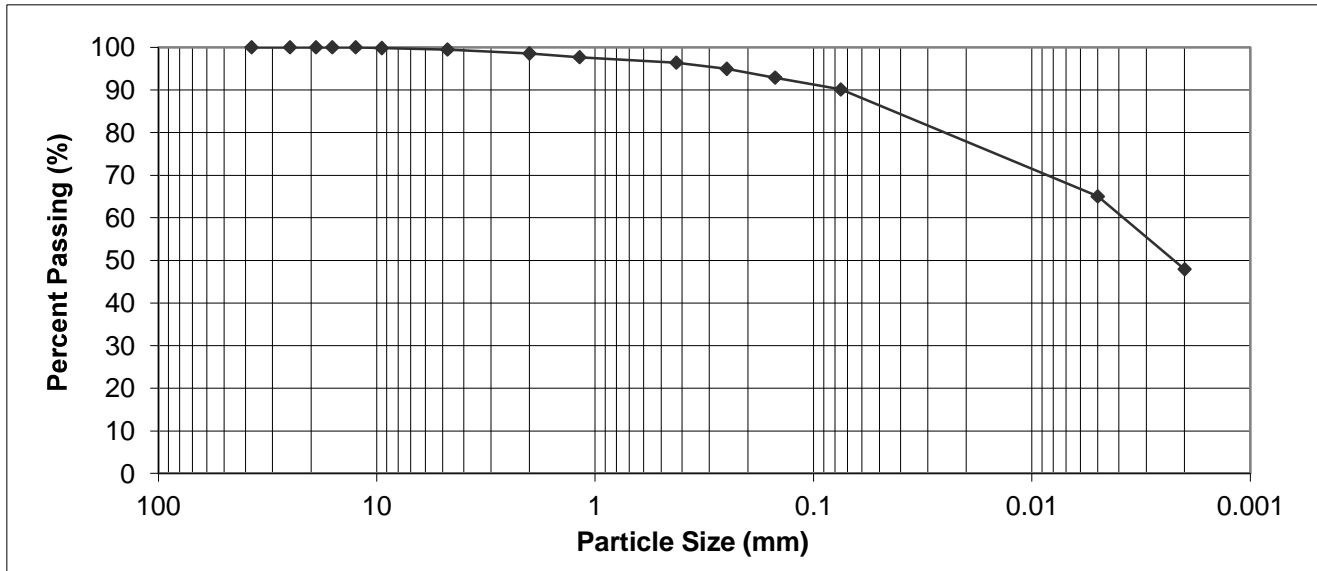

PARTICLE SIZE	PERCENT PASSING	PARTICLE SIZE	PERCENT PASSING
37.50 mm	100.0	1.18 mm	97.7
25.00 mm	100.0	0.425 mm	96.4
19.00 mm	100.0	0.250 mm	94.9
16.00 mm	100.0	0.150 mm	92.9
12.50 mm	100.0	0.075 mm	90.1
9.50 mm	99.8	0.005 mm	65.0
4.75 mm	99.5	0.002 mm	47.9
2.00 mm	98.6	0.001 mm	NT

Gravel, % 75 to 4.75 mm	Sand, %			Silt, % <0.075 to 0.005 mm	Clay, % <0.005 mm	Colloids, % < 0.001 mm
	Coarse <4.75 to 2.0 mm	Medium <2.0 to 0.425 mm	Fine <0.425 to 0.075 mm			
0.5	0.9	2.2	6.3	25.1	65.0	NT

Note: Colloids content not tested

December 9, 2011

REVIEWED BY: Farouk Fourar, EIT



PARTICLE SIZE ANALYSIS ASTM D422

J.R. Cousin Consultants Ltd.
91A Scurfield Blvd.
Winnipeg, Manitoba
R3Y 1G4

PROJECT: South Whiteshell Truck Haul Lagoon

Attention: Brett McCormac

PROJECT NO.: JRC-1112

SAMPLED BY: Client
SAMPLE ID: TH8 at 2.7-5.1 m

DATE RECEIVED: November 10, 2011
TESTED BY: Sothea Bun

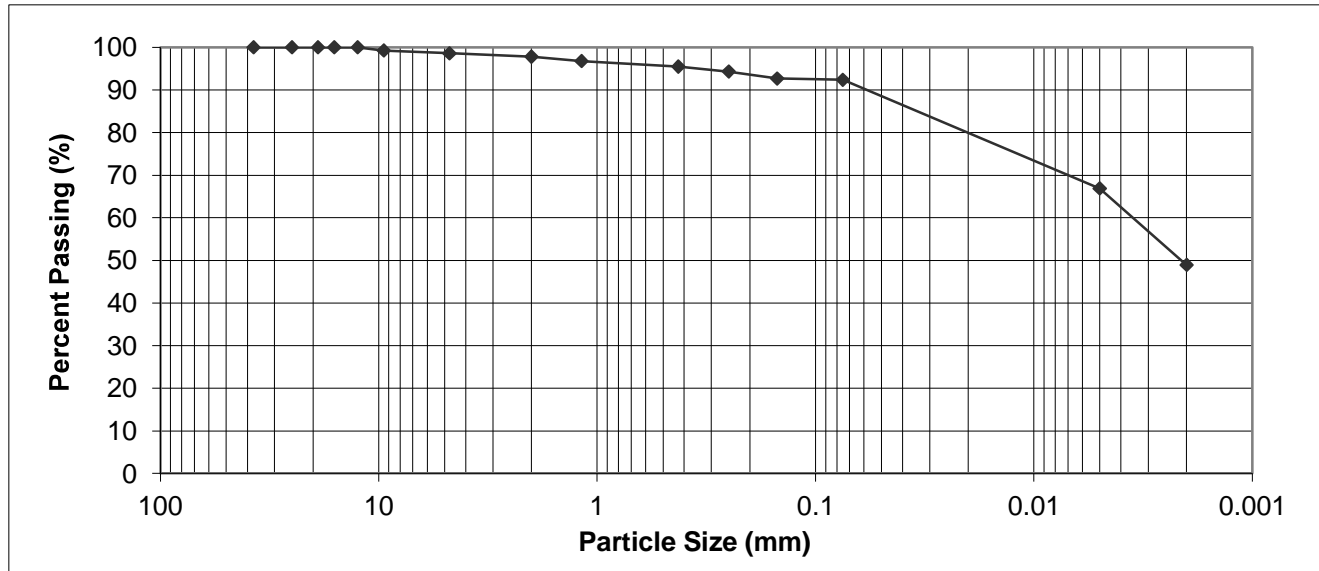

PARTICLE SIZE	PERCENT PASSING	PARTICLE SIZE	PERCENT PASSING
37.50 mm	100.0	1.18 mm	96.8
25.00 mm	100.0	0.425 mm	95.5
19.00 mm	100.0	0.250 mm	94.3
16.00 mm	100.0	0.150 mm	92.7
12.50 mm	100.0	0.075 mm	92.4
9.50 mm	99.2	0.005 mm	66.9
4.75 mm	98.6	0.002 mm	48.9
2.00 mm	97.8	0.001 mm	NT

Gravel, % 75 to 4.75 mm	Sand, %			Silt, % <0.075 to 0.005 mm	Clay, % <0.005 mm	Colloids, % < 0.001 mm
	Coarse <4.75 to 2.0 mm	Medium <2.0 to 0.425 mm	Fine <0.425 to 0.075 mm			
1.4	0.8	2.3	3.1	25.5	66.9	NT

Note: Colloids content not tested

December 9, 2011

REVIEWED BY: Farouk Fourar, EIT

HYDRAULIC CONDUCTIVITY ASTM D5084

J.R.Cousin Consultants Ltd.
91A Scurfield Blvd.
Winnipeg, Manitoba
R3Y 1G4

PROJECT: South Whiteshell Truck Haul Lagoon

Attention: Brett McCormac

SAMPLE I.D.: TH1 at 0.6-2.3 m
SOIL TYPE: brown, firm, moist, medium plasticity clay, silty, trace gravel and sand
DATE TESTED: December 9 to 15, 2011
CONFINING PRESSURE (kPa): 137.9
EFFECTIVE SATURATION STRESS (kPa): 34.5
HYDRAULIC GRADIENT: 21.4
TYPE OF PERMEANT LIQUID: De-aired Water
HYDRAULIC CONDUCTIVITY, "k" (cm/s): 7.5E-09
HYDRAULIC CONDUCTIVITY, "k₂₀" (cm/s): 7.7E-09

	Height (mm)	Diameter (mm)	Wet Mass (g)	Dry Density (g/cm ³)	Water Content (%)	Saturation (%)
Initial Reading	69.4	70.7	550.8	1.646	22.9	96.3
Final Reading	69.0	71.4	556.3	1.605	25.7	101.8

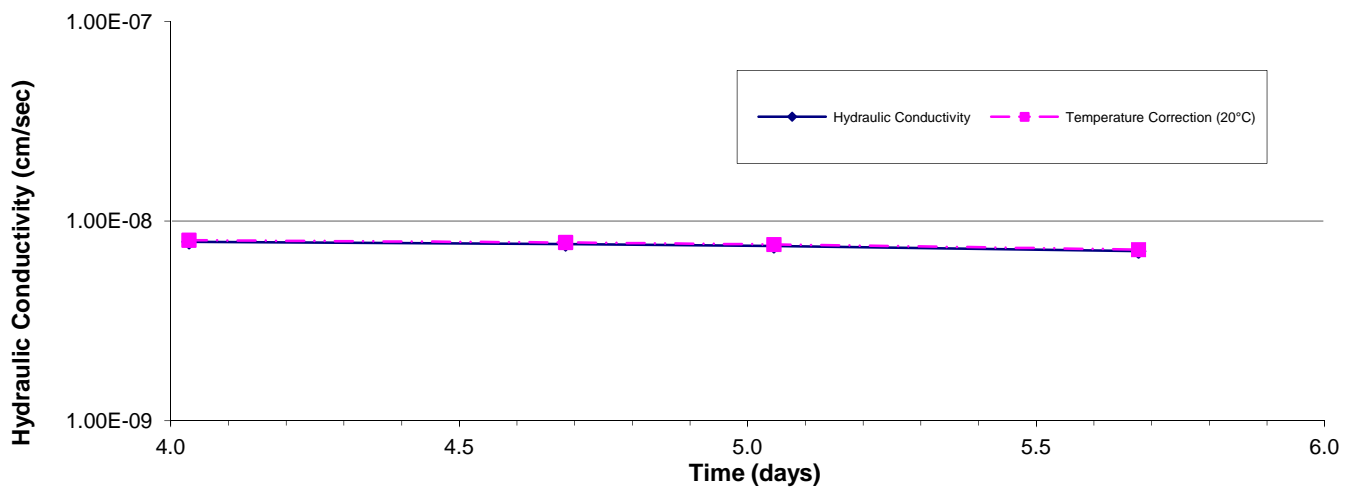

Note: Sample was lab-remoulded prior to testing

December 16, 2011

REVIEWED BY: Aron Piamsalee, B.Sc., EIT

Appendix C

Table 1: Population, Hydraulic and Organic Loading Projections for the South
Whiteshell Truck-Haul Lagoon

Water Stewardship, January 31, 2012 E-mail Correspondence

Manitoba Water Stewardship, Fisheries Branch – February 13, 2012 E-mail
Correspondence

Manitoba Conservation Wildlife and Ecosystem Protection Branch, January 30,
2012 E-mail Correspondence

Manitoba Conservation Historic Resources Branch, February 6, 2012
Memorandum

Table 1: Population, Hydraulic and Organic Loading Projections for the South
Whiteshell Truck-Haul Lagoon

TABLE 1
POPULATION, HYDRAULIC AND ORGANIC LOADING PROJECTIONS FOR THE SOUTH WHITESHELL TRUCK-HAUL LAGOON

PROJECT YEAR	YEAR	Col 3	Col 4	Col 5	Col 6	Col 7	Col 8	Col 9	Col 10	Col 11	Col 12	Col 13	Col 14	Col 15	Col 16	Col 17	Col 18	Col 19	Col 20	Col 21	Col 22	Col 23	Col 24	Col 25	Col 26	Col 27	Col 28	Col 29	Col 30	Col 31	Col 32	Col 33	Col 34	Col 35	Col 36	Col 37				
		POPULATION												POPULATION SUMMARY				ORGANIC LOADING					HYDRAULIC LOADING																	
		FULL TIME COTTAGES* ON HOLDING TANKS** Average Occupancy of 2.5 people/cottage		FULL TIME COTTAGES* ON SEPTIC TANKS** Average Occupancy of 2.5 people/cottage		SEASONAL COTTAGES* ON HOLDING TANKS** Average Occupancy of 4 people/cottage and an Equivalent Occupancy of (45/153)		SEASONAL COTTAGES* ON SEPTIC TANKS** Average Occupancy of 4 people/cottage and an Equivalent Occupancy of (45/153)		SEASONAL EQUIVALENT RESORT, BUSINESS AND NON-PROFIT POPULATIONS on Holding Tanks**		SEASONAL EQUIVALENT RESORT, BUSINESS AND NON-PROFIT POPULATIONS on Septic Tanks**		OFF-SEASON EQUIVALENT RESORT, BUSINESS AND NON-PROFIT POPULATIONS on Holding Tanks**		OFF-SEASON EQUIVALENT RESORT, BUSINESS AND NON-PROFIT POPULATIONS on Septic Tanks**		SEASONAL REMOTE COTTAGES ON SEPTIC TANKS Average Occupancy of 4 people/cottage and an Equivalent Occupancy of (45/153)		FULL TIME REMOTE COTTAGES ON SEPTIC TANKS Average Occupancy of 2.5 people/cottage		REMOTE NON-PROFITS ON SEPTIC TANKS Equivalent Occupancy of 1/3		TOTAL EQUIVALENT POPULATION On Holding Tanks In Season	TOTAL EQUIVALENT POPULATION On Holding Tanks Off Season	TOTAL EQUIVALENT POPULATION On Septic Tanks In Season	TOTAL EQUIVALENT POPULATION On Septic Tanks Off Season	DAILY PER CAPITA BOD	BOD PRODUCTION	DAILY BOD PRODUCTION	DAILY BOD PRODUCTION	DAILY BOD PRODUCTION	SURFACE AREA REQ'D AT 0.75 M DEPTH	DAILY CAPITA WATER USE/EA	Yearly Capita WW Prod (Septic Tanks)	TOTAL SEPTIC TANK WASTEWATER PRODUCTION In Season (153 Days) (Col 23* Col 32/1000)* (153/365)	TOTAL SEPTIC TANK WASTEWATER PRODUCTION Off Season (212 Days) (Col 24* Col 32/1000)* (212/365)	TOTAL DAILY WASTEWATER PRODUCTION FROM HOLDING TANKS In Season Col 21* Col 31/1000	TOTAL DAILY WASTEWATER PRODUCTION FROM HOLDING TANKS Off Season Col 22* Col 31/1000	365 Day WASTEWATER PRODUCTION
		# Cottages	# People	# Cottages	# People	# Cottages	# Equivalent People	# Cottages	# Equivalent People	# Equivalent People	# Equivalent People	# Equivalent People	# Equivalent People	# Equivalent People	# Equivalent People	# Cottages	# Equivalent People	Actual	# Equivalent People	Col 4 + Col 8 + Col 11	Col 4 + Col 13	Col 6 + Col 10 + Col 12 + Col 16 + Col 18 + Col 20	Col 6 + Col 14 + Col 18 + Col 20	(kg BOD ₅ /person/day)	(kg m ⁻³)	(kg)	(kg)	(kg)	(kg)	(m ²)	(L/person/day)	(litres)	(m ³)	(m ³)	(m ³)	(m ³)	(m ³)			
0	2011	14	35	91	228	165	194	1084	1275	21	140	4	28	0	0	0	0	0	0	250	39	1,643	255	0.076	7.0	19.0	17.0	36.1	6,439	150	200	137.7	29.7	37.6	5.9	7,160				
20	2031	105	263	0	0	1249	1469	0	0	161	0	32	0	149	175	5	13	2	0.7	1,893	295	188	13	0.076	7.0	143.9	2.0	145.9	26,045	150	200	15.8	1.5	284.0	44.3	52,852				

**Based on 7.8% full time and 92.2% seasonal
**Based on 86.8% septic tanks and 13.2% holding tanks in 2011 and 100% holding tanks in 2031

Water Stewardship, January 31, 2012 E-mail Correspondence

Brett McCormac

From: Allum, Brad (MWS) [Brad.Allum@gov.mb.ca]
Sent: January 31, 2012 1:54 PM
To: 'Brett McCormac'
Subject: RE: Flood Data for Falcon Lake

Hi Brett,

We do not have a 100 year flood level for Falcon Lake. The highest recorded water surface elevation is about 1068 feet, recorded in the early 1960's.

Brad

From: Brett McCormac [<mailto:bmccormac@jrcc.ca>]
Sent: January-31-12 9:14 AM
To: Allum, Brad (MWS)
Subject: Flood Data for Falcon Lake

Hello Brad,

I was wondering if you have any flood data (1 in 100 year) for Falcon Lake. We are evaluating a lagoon southwest of Falcon Lake in SE ¼ of 19-08-16-E.

Brett McCormac, E.I.T.
Environmental Engineer-in-Training

J.R. Cousin Consultants Ltd.
Phone: (204) 489-0474
Fax: (204) 489-0487
www.jrcc.ca

Manitoba Water Stewardship, Fisheries Branch – February 13, 2012 E-mail
Correspondence

Brett McCormac

From: Janusz, Laureen R (MWS) [Laureen.Janusz@gov.mb.ca]
Sent: February 13, 2012 2:05 PM
To: bmccormac@jrcc.ca
Cc: Leroux, Doug (MWS)
Subject: South Whiteshell Truck Haul Lagoon - Fisheries Boggy River Information request

Hi Brett,

I am so sorry for the delay in responding. Boggy River provides year round habitat for a diverse assemblage of fish species including two species of special concern: northern brook lamprey and carmine shiner. Other species identified in the Fisheries Inventory and Habitat Classification System (FIHCS) are: northern pike, shorthead redhorse, walleye, white sucker, central mudminnow, pearl dace, mimic shiner, finescale dace, fathead minnow, Johnny darter, brook stickleback, rock bass, blackside darter, common shiner, hornyhead chub, spottail shiner, longnose dace and iowa darter. It is also noted in the FIHCS that Boggy River was rated as a waterbody with only slight limitations to fish production.

Our concern with the proposed lagoon would be any potential for the effluent to degrade water quality in Boggy River. Given the effluent should meet or exceed Manitoba Water Quality Standards, Objectives and Guidelines prior to discharge, there is quite a distance the effluent will travel before reaching Boggy River and the route is through areas of bog and wetlands, one would anticipate there should be minimal effects from the effluent.

Laureen Janusz
Fisheries Science and Fish Culture Section
Fisheries Branch
Conservation and Water Stewardship
Phone: 204 945-7789
Cell: 204 793-1154
Email: Laureen.Janusz@gov.mb.ca

From: Brett McCormac [<mailto:bmccormac@jrcc.ca>]
Sent: January-30-12 11:11 AM
To: Janusz, Laureen R (MWS)
Subject: South Whiteshell Truck Haul Lagoon - Fisheries

Hi Laureen,

J.R. Cousin Consultants Ltd. (JRCC) is preparing an Environmental Act Proposal for the South Whiteshell truck haul lagoon to service West Hawk, Falcon Lake and the surrounding area. The lagoon is proposed to be located within the Whiteshell Provincial Park on the SE1/4 or the SW1/4 of 19-08-16-E.

Drainage from the proposed new lagoon will drain through areas of bog and wetlands and the exact discharge route cannot be known. Treated effluent is expected to flow southwest through the Whiteshell Bog with eventual discharge into the Boggy River.

Could you please respond with any comments or concerns you have with the proposed project. Also, could you please provide a list of the fish species that are found in the Boggy River, if available.

Thank you,

Brett McCormac, E.I.T.
Environmental Engineer-in-Training

J.R. Cousin Consultants Ltd.
Phone: (204) 489-0474
Fax: (204) 489-0487
www.jrcc.ca

Manitoba Conservation Wildlife and Ecosystem Protection Branch, January 30,
2012 E-mail Correspondence

Brett McCormac

From: Friesen, Chris (CON) [Chris.Friesen@gov.mb.ca]
Sent: January 30, 2012 1:16 PM
To: 'Brett McCormac'
Subject: RE: South Whiteshell Truck Haul Lagoon - Species at Risk

Brett

Thank you for your information request. I completed a search of the Manitoba Conservation Data Centre's rare species database and found no occurrences at this time for your area of interest.

The information provided in this letter is based on existing data known to the Manitoba Conservation Data Centre at the time of the request. These data are dependent on the research and observations of CDC staff and others who have shared their data, and reflect our current state of knowledge. **An absence of data in any particular geographic area does not necessarily mean that species or ecological communities of concern are not present;** in many areas, comprehensive surveys have never been completed. Therefore, this information should be regarded neither as a final statement on the occurrence of any species of concern, nor as a substitute for on-site surveys for species as part of environmental assessments. Also, because the Manitoba CDC's Biotics database is continually updated and because information requests are evaluated by type of action, any given response is only appropriate for its respective request.

Please contact the Manitoba CDC for an update on this natural heritage information if more than six months pass before it is utilized.

Third party requests for products wholly or partially derived from Biotics must be approved by the Manitoba CDC before information is released. Once approved, the primary user will identify the Manitoba CDC as data contributors on any map or publication using Biotics data, as follows as: Data developed by the Manitoba Conservation Data Centre; Wildlife and Ecosystem Protection Branch, Manitoba Conservation.

We would be interested in receiving a copy of the results of any field surveys that you may undertake, to update our database with the most current knowledge of the area.

If you have any questions or require further information please contact me directly at (204) 945- 7747.

Chris Friesen
Biodiversity Information Manager
Manitoba Conservation Data Centre
204-945-7747
chris.friesen@gov.mb.ca
<http://www.gov.mb.ca/conservation/cdc/>

From: Brett McCormac [<mailto:bmccormac@jrcc.ca>]
Sent: January-30-12 10:45 AM
To: Friesen, Chris (CON); Firlotte, Nicole (CON)
Subject: South Whiteshell Truck Haul Lagoon - Species at Risk

Hi,

J.R. Cousin Consultants Ltd. (JRCC) is preparing an Environmental Act Proposal for the South Whiteshell truck haul lagoon to service West Hawk, Falcon Lake and the surrounding area. The lagoon is proposed to be located within the Whiteshell Provincial Park on the SE1/4 or the SW1/4 of 19-08-16-E.

Could you please confirm there are no 'species at risk' known to exist on the property.

Thank you,

Brett McCormac, E.I.T.
Environmental Engineer-in-Training

J.R. Cousin Consultants Ltd.

Phone: (204) 489-0474

Fax: (204) 489-0487

www.jrcc.ca

Manitoba Conservation Historic Resources Branch, February 6, 2012
Memorandum

DATE: February 6th, 2012

To: Brett McCormac
Environmental Engineer-in-Training
J.R. Cousin Consultants Ltd.

From: Jenny Payment
Impact Assessment Archaeologist
Historic Resources Branch
Main Floor 213 Notre Dame Ave
Wpg, MB R3B 1N3
Phone #: (204) 945-4768

Subject: South Whiteshell Truck Haul Lagoon

HRB FILE: AAS-11-3769

Further to your memo regarding the above mentioned development project, I have examined the location in conjunction with Historic Resources Branch records for areas of potential concern. The Historic Resources Branch has **no concerns** with the proposed project.

If at any time heritage resources are encountered in association with this project during any development, the Historic Resources Branch may require that a heritage resource management strategy be implemented by the developer to mitigate the effects of development on any heritage resources.

If you have any questions or comments, please feel free to contact me (Jenny Payment), by phone (see above), or by email: Jen.Payment@gov.mb.ca.

Jenny Payment

Appendix D

Title Page

Plan 1: Proposed Lagoon Layout with Test Hole Locations and Topographic Contour Lines

Plan 2: Proposed Lagoon Discharge Route

Plan 3: Proposed Lagoon Layout

Plan 4: Perimeter Dike, Intercell Dike, Valve, Valve Marker, Sign, Rip Rap, Ditch and Access Road Details

Plan 5: Spillway, Truck Turnaround, Silt Fence, Fence, Gate and Lock Details

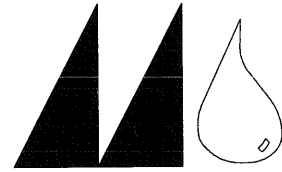

THE MANITOBA
WATER SERVICES BOARD

SOUTH WHITESHELL PROVINCIAL PARK

TRUCK-HAUL LAGOON

ENVIRONMENTAL ACT PROPOSAL

PRELIMINARY
NOT FOR CONSTRUCTION

REDUCED DRAWING
50% SCALE

PLAN INDEX

LAGOON

- PLAN 1. PROPOSED LAGOON LAYOUT WITH TEST HOLE LOCATIONS AND TOPOGRAPHIC CONTOUR LINES
- PLAN 2. PROPOSED LAGOON DISCHARGE ROUTE
- PLAN 3. PROPOSED LAGOON LAYOUT
- PLAN 4. PERIMETER DIKE, INTERCELL DIKE, VALVE, VALVE MARKER, SIGN, RIP RAP, DITCH AND ACCESS ROAD DETAILS
- PLAN 5. SPILLWAY, TRUCK TURNAROUND, SILT FENCE, FENCE, GATE AND LOCK DETAILS



J. R. Cousin Consultants Ltd.
Consulting Engineers and Project Managers

91A Scurfield Blvd.
ph: (204) 489-0474
email: info@jrcc.ca

Winnipeg, MB R3Y 1G4
fax: (204) 489-0487
website: www.jrcc.ca

Engineering Excellence since 1981



PRELIMINARY
NOT FOR CONSTRUCTION

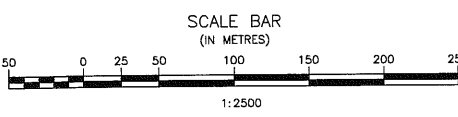

No.	REVISIONS	DATE	INITIALS

B.M. ELEV.

LOCATIONS OF UNDERGROUND STRUCTURES/UTILITIES AS SHOWN ARE BASED ON AVAILABLE INFORMATION BUT NO GUARANTEE IS GIVEN OR IMPLIED THAT ALL EXISTING UNDERGROUND STRUCTURES/UTILITIES ARE SHOWN OR THAT THE GIVEN LOCATIONS ARE EXACT. CONFIRMATION OF EXISTENCE AND EXACT LOCATION OF ALL UNDERGROUND STRUCTURES/UTILITIES MUST BE OBTAINED FROM THE APPROPRIATE AUTHORITY/OWNER, BY THE CONTRACTOR, BEFORE PROCEEDING WITH CONSTRUCTION.

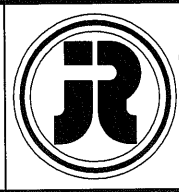
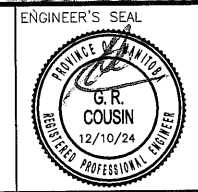
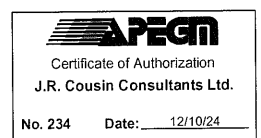

J. R. Cousin Consultants Ltd.
Consulting Engineers and Project Managers

91A Scurfield Blvd. Winnipeg, MB R3Y 1G4
ph: (204) 489-0474 fax: (204) 489-0487
email: info@jrcc.ca website: www.jrcc.ca

Engineering Excellence since 1981

CODE:	S-633.01	PROJECT:	SOUTH WHITESHELL PROVINCIAL PARK TRUCKHAUL LAGOON FEASIBILITY STUDY
DESIGNED BY:	JC	TITLE:	PROPOSED LAGOON LAYOUT WITH TEST HOLE LOCATIONS AND TOPOGRAPHIC CONTOUR LINES
DRAWN BY:	BM	SCALE:	1:2500
REVIEWED BY:	JC	DATE:	12/10/05
		PLAN:	1
		SHEET:	1 of 5

Oct 24, 2012 1:18pm F:\000\033 South Whiteshell Provincial Park\ASD1\Truckhaul Lagoon Feasibility Study\04 - Damaged\img\MAP11.dwg

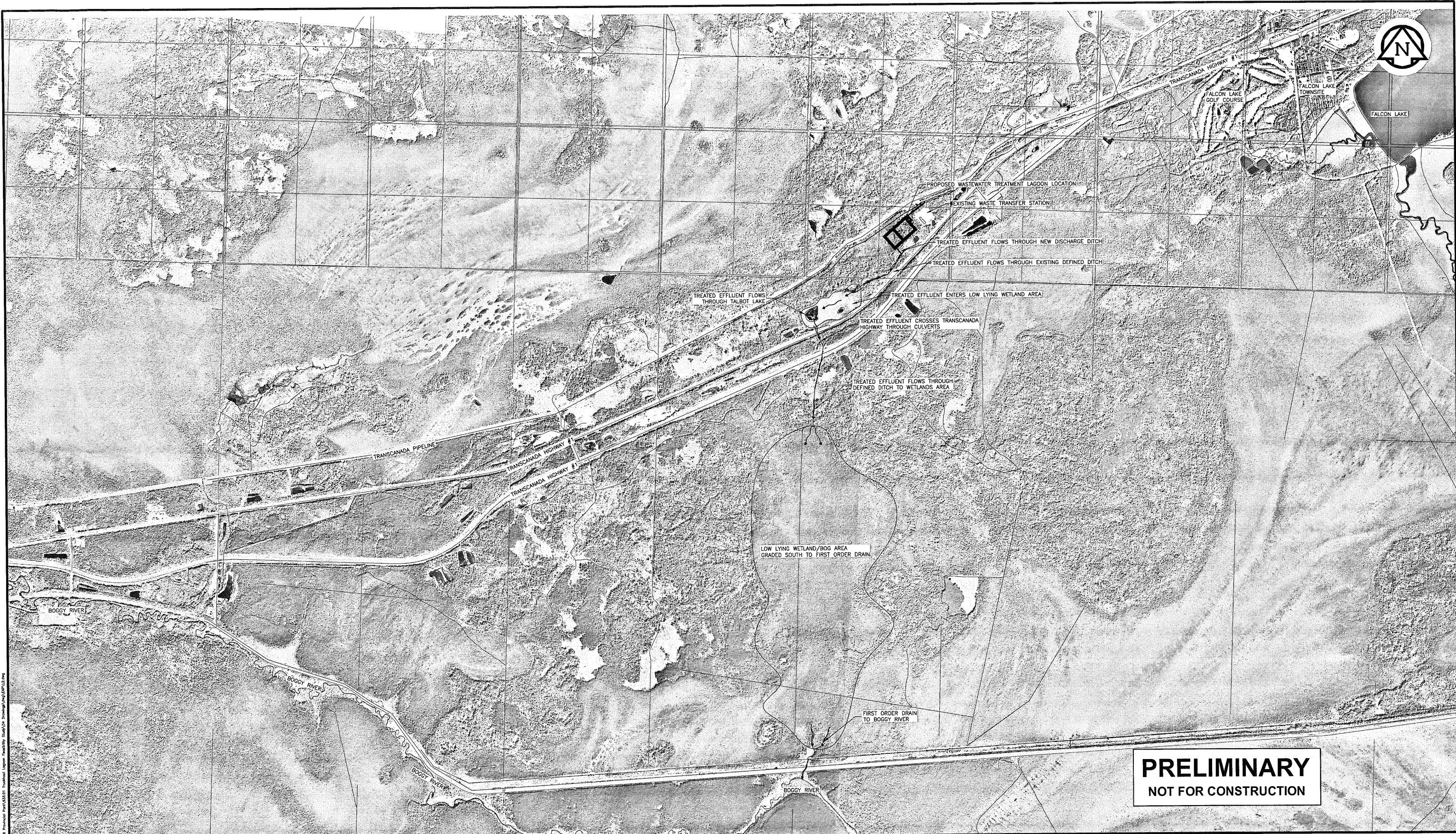

PRELIMINARY
NOT FOR CONSTRUCTION

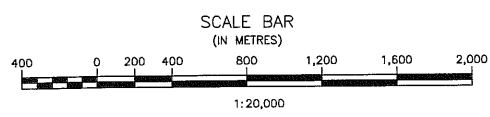

No.	REVISIONS	DATE	INITIALS

B.M. ELEV.

LOCATIONS OF UNDERGROUND STRUCTURES/UTILITIES AS SHOWN ARE BASED ON AVAILABLE INFORMATION BUT NO GUARANTEE IS GIVEN OR IMPLIED THAT ALL EXISTING UNDERGROUND STRUCTURES/UTILITIES ARE SHOWN OR THAT THE GIVEN LOCATIONS ARE EXACT. CONFIRMATION OF EXISTENCE AND EXACT LOCATION OF ALL UNDERGROUND STRUCTURES/UTILITIES MUST BE OBTAINED FROM THE APPROPRIATE AUTHORITY/OWNER, BY THE CONTRACTOR, BEFORE PROCEEDING WITH CONSTRUCTION.

PEGM
Certificate of Authorization
J.R. Cousin Consultants Ltd.
No. 234 Date: 12/10/24

ENGINEER'S SEAL
PROVINCE OF MANITOBA
G. R. COUSIN
12/10/24
REGISTERED PROFESSIONAL ENGINEER

J. R. Cousin Consultants Ltd.
Consulting Engineers and Project Managers
91A Scurlfield Blvd. Winnipeg, MB R3Y 1G4
ph: (204) 489-0474 fax: (204) 489-0487
email: info@jrcc.ca website: www.jrcc.ca
Engineering Excellence since 1981

CODE: S-633.01	PROJECT: SOUTH WHITESHELL PROVINCIAL PARK TRUCKHAUL LAGOON FEASIBILITY STUDY
DESIGNED BY: JC	TITLE: PROPOSED LAGOON DISCHARGE ROUTE
DRAWN BY: BM	SCALE: 1:20,000
REVIEWED BY: JC	DATE: 12/10/05
	PLAN: 2
	SHEET: 2 of 5

Oct 24, 2012 - 11:00am T:\000\033 South Whiteshell Provincial Park\AS01 Technical\Report Feasibility Study\01 Drawings\Map\04\05.dwg

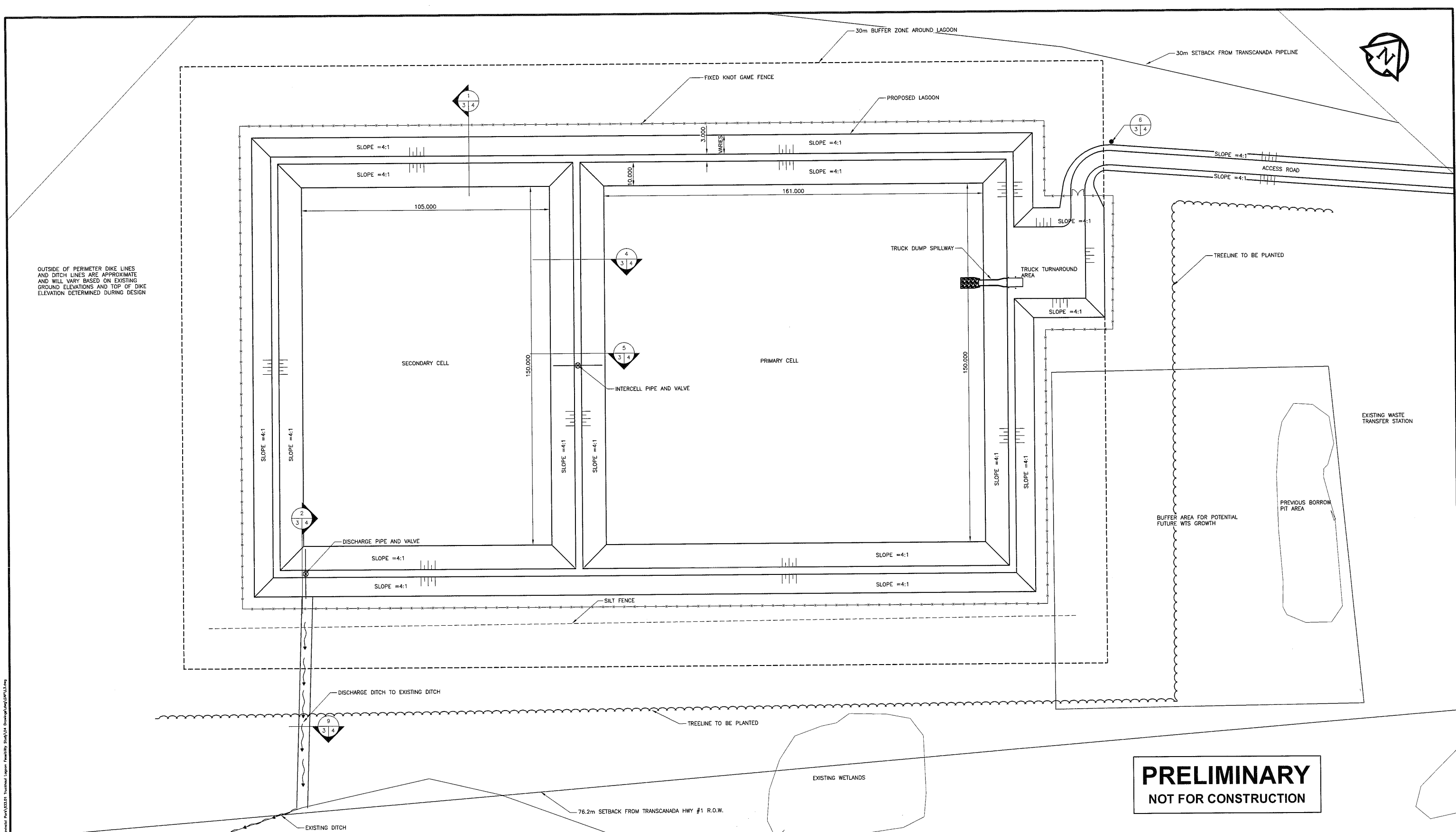

PRELIMINARY
NOT FOR CONSTRUCTION

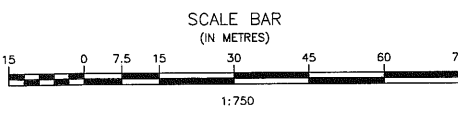

No.	REVISIONS	DATE	INITIALS

B.M. ELEV.

LOCATIONS OF UNDERGROUND STRUCTURES/UTILITIES AS SHOWN ARE BASED ON AVAILABLE INFORMATION BUT NO GUARANTEE IS GIVEN OR IMPLIED THAT ALL EXISTING UNDERGROUND STRUCTURES/UTILITIES ARE SHOWN OR THAT THE GIVEN LOCATIONS ARE EXACT. CONFIRMATION OF EXISTENCE AND EXACT LOCATION OF ALL UNDERGROUND STRUCTURES/UTILITIES MUST BE OBTAINED FROM THE APPROPRIATE AUTHORITY/OWNER, BY THE CONTRACTOR, BEFORE PROCEEDING WITH CONSTRUCTION.

APECM
Certificate of Authorization
J.R. Cousin Consultants Ltd.
No. 234 Date: 12/10/24

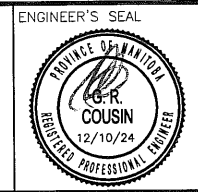

J. R. Cousin Consultants Ltd.
Consulting Engineers and Project Managers
91A Scurfield Blvd. Winnipeg, MB R3Y 1G4
ph: (204) 489-0474 fax: (204) 489-0487
email: info@jrcc.ca website: www.jrcc.ca
Engineering Excellence since 1981

CODE: S-633.01	PROJECT: SOUTH WHITESHELL PROVINCIAL PARK TRUCKHAUL LAGOON FEASIBILITY STUDY
DESIGNED BY: JC	TITLE: PROPOSED LAGOON LAYOUT
DRAWN BY: BM	SCALE: 1:750
REVIEWED BY: JC	DATE: 12/10/05
PLAN: 3	SHEET: 3 of 5

04/24/2012 11:11am F:\000\033 South Whiteshell Provincial Park\033\01 Treatment Support Feasibility Study\04 DWG\Proposed Lagoon Layout.dwg

LEGEND:

- EXCAVATED AND COMPACTED MEDIUM PLASTIC CLAY TYPE SOIL
- EXCAVATED AND COMPACTED MIXTURE OF SOILS
- INSITU MEDIUM PLASTIC CLAY TYPE SOIL
- RIP RAP
- TOPSOIL
- EXCAVATED AND COMPACTED MEDIUM PLASTIC CLAY TYPE SOIL

LEVEL 1 - PRE-CONSTRUCTION EXISTING GROUND ELEVATION
 LEVEL 2 - ELEVATION FOLLOWING TOPSOIL REMOVAL
 LEVEL 3 - FINISHED CELL BOTTOM ELEVATION
 LEVEL 4 - BOTTOM OF HORIZONTAL LINER AND CUTOFF WALL

COVER DETAIL
SCALE = 1:10

LEGEND:

- INSITU SOIL
- EXCAVATED AND COMPACTED SOILS SUITABLE FOR DIKE CONSTRUCTION

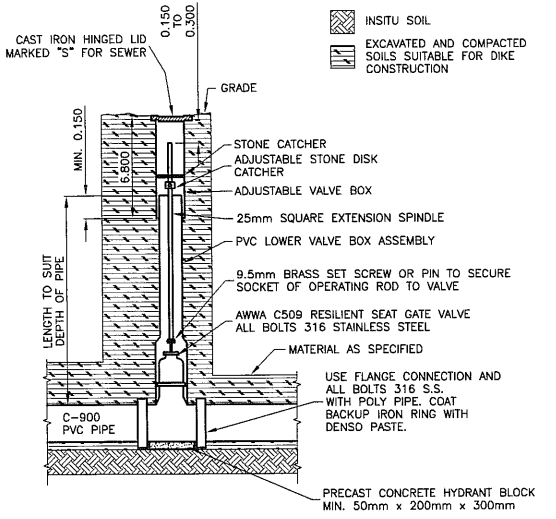

3 TYPICAL VALVE DETAIL
SCALE = 1:25

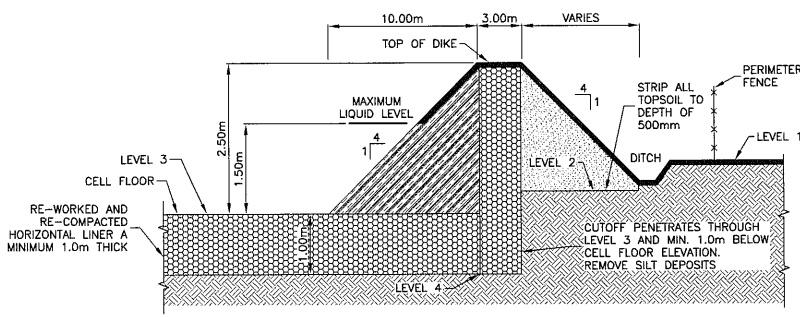

1 PERIMETER DIKE
HOR = 1:250
VER = 1:50

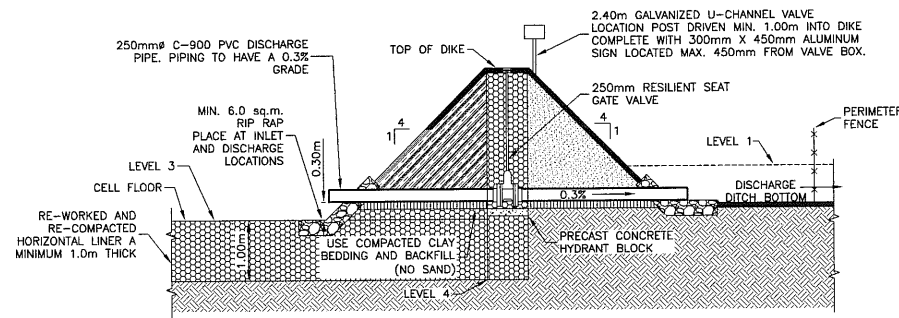

2 PERIMETER DIKE AT DISCHARGE PIPE
HOR = 1:250
VER = 1:50

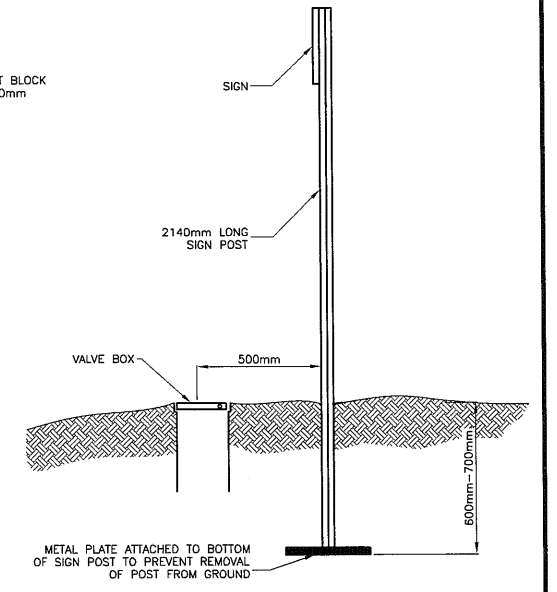

NOTES:
 - MINIMUM SIGN SIZE: 300mm X 450mm
 - MINIMUM POST LENGTH: 2140mm
 - CROSSING MARKERS TO BE SET IN 200mmØ X 1.0m CONCRETE AS PER SPECIFICATIONS

7 VALVE MARKER DETAIL
SCALE = 1:15

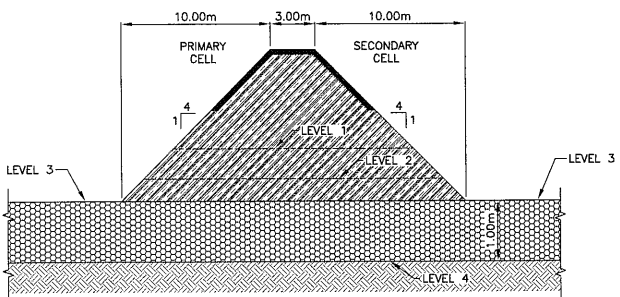

4 INTERCELL DIKE
HOR = 1:250
VER = 1:50

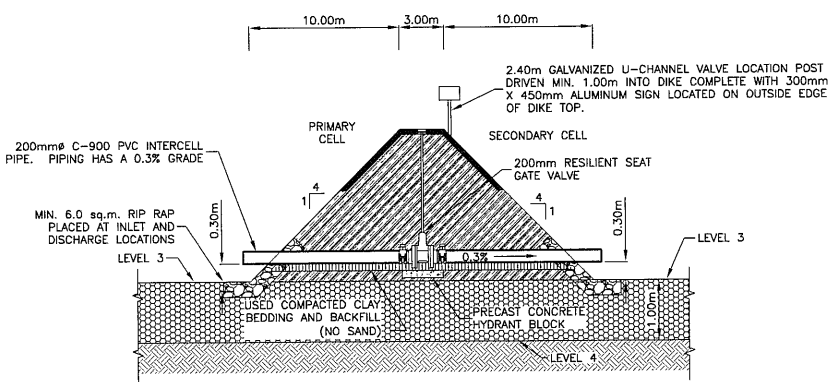

5 INTERCELL DIKE AT INTERCELL PIPE
HOR = 1:250
VER = 1:50

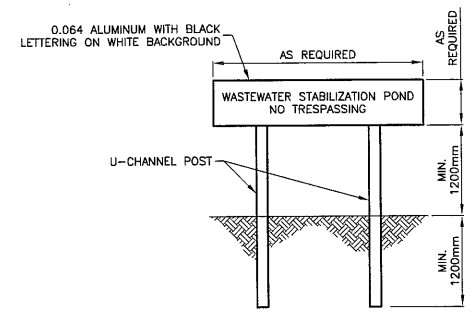

6 LAGOON SITE MARKER DETAIL
SCALE = 1:50

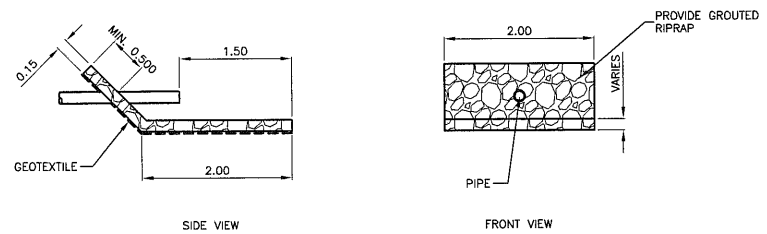

NOTE:
 -RIPRAP MATERIAL SHALL BE WELL GRADED 125mm TO 150mm HARD, DENSE, ROUNDED & DURABLE FIELD STONE.

8 RIPRAP DETAIL
SCALE = 1:50

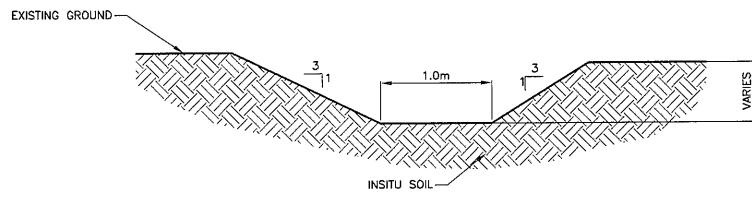

9 TYPICAL DISCHARGE DITCH DETAIL
SCALE = NTS

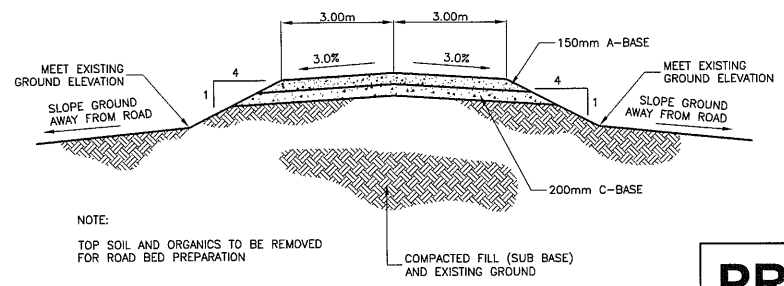

NOTE:
 TOP SOIL AND ORGANICS TO BE REMOVED FOR ROAD BED PREPARATION

10 TYPICAL ACCESS ROAD CROSS-SECTION
Horizontal Scale = 1:100
Vertical Scale = 1:50

PRELIMINARY
NOT FOR CONSTRUCTION

No.	REVISIONS	DATE	INITIALS	B.M. ELEV.

LOCATIONS OF UNDERGROUND STRUCTURES/UTILITIES AS SHOWN ARE BASED ON AVAILABLE INFORMATION BUT NO GUARANTEE IS GIVEN OR IMPLIED THAT ALL EXISTING UNDERGROUND STRUCTURES/UTILITIES ARE SHOWN OR THAT THE GIVEN LOCATIONS ARE EXACT. CONFIRMATION OF EXISTENCE AND EXACT LOCATION OF ALL UNDERGROUND STRUCTURES/UTILITIES MUST BE OBTAINED FROM THE APPROPRIATE AUTHORITY/OWNER, BY THE CONTRACTOR, BEFORE PROCEEDING WITH CONSTRUCTION.

APECM
 Certificate of Authorization
J.R. Cousin Consultants Ltd.
 No. 234 Date: 12/10/24

ENGINEER'S SEAL
J.R. COUSIN
 REGISTERED PROFESSIONAL ENGINEER



J. R. Cousin Consultants Ltd.
 Consulting Engineers and Project Managers
 91A Scurlfield Blvd. Winnipeg, MB R3Y 1G4
 ph: (204) 489-0474 fax: (204) 489-0487
 email: info@jrcc.ca website: www.jrcc.ca

CODE: S-633.01	PROJECT: SOUTH WHITESHELL PROVINCIAL PARK TRUCKHAUL LAGOON FEASIBILITY STUDY
DESIGNED BY: JC	TITLE: PERIMETER DIKE, INTERCELL DIKE, VALVE, VALVE MARKER, SIGN, RIP RAP, DITCH AND ACCESS ROAD DETAILS
DRAWN BY: BM	SCALE: AS NOTED
REVIEWED BY: JC	DATE: 12/10/05
PLAN: 4	SHEET: 4 of 5

04_24_2012 - 11:30am F:\000\033 South Whiteshell Provincial Park\03307 Truckhaul Lagoon Feasibility Study\04 Drawings\DWG\DWG.dwg

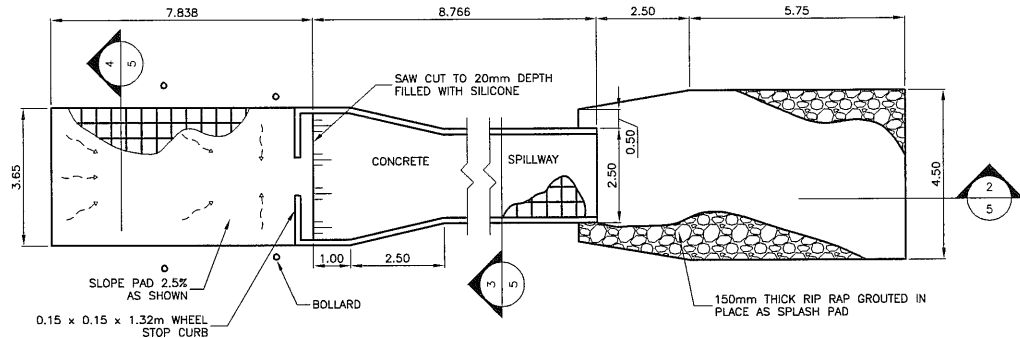

1 SPILLWAY PLAN VIEW
Scale = 1:100

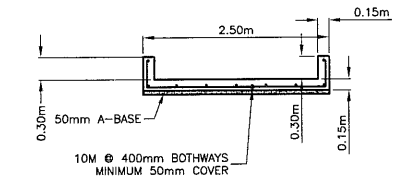

3 CONCRETE SPILLWAY SECTION
Scale = 1:50

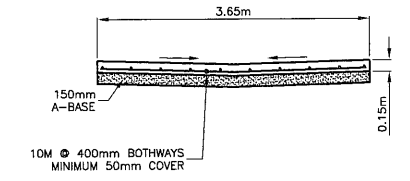

4 CONCRETE PAD SECTION
Scale = 1:50

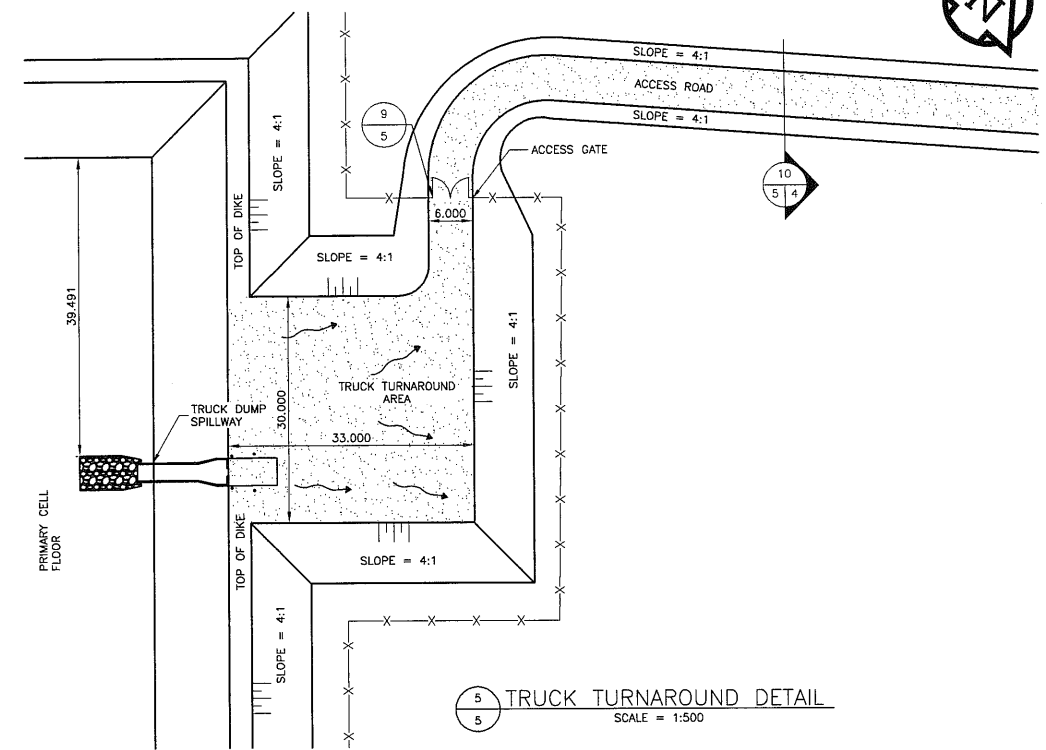

5 TRUCK TURNAROUND DETAIL
SCALE = 1:500

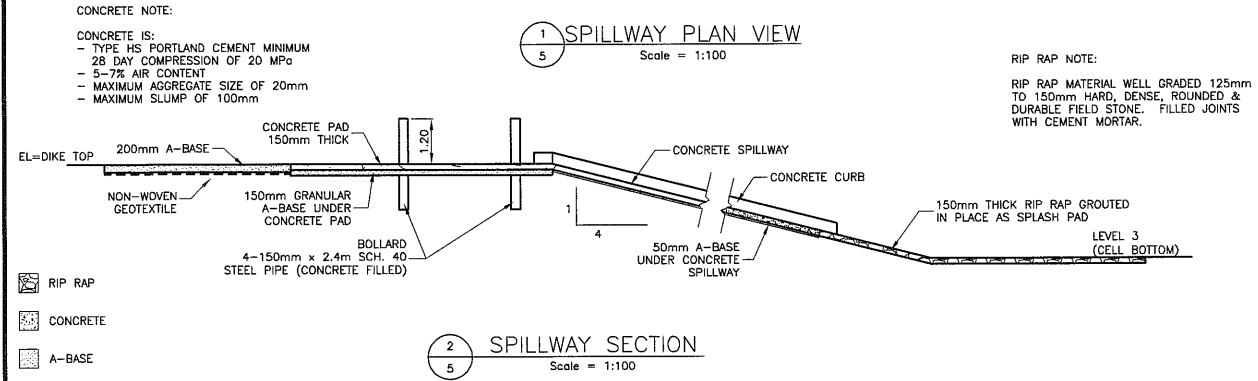

2 SPILLWAY SECTION
Scale = 1:100

CONCRETE NOTE:
CONCRETE IS:
- TYPE HS PORTLAND CEMENT MINIMUM 28 DAY COMPRESSION OF 20 MPa
- 5-7% AIR CONTENT
- MAXIMUM AGGREGATE SIZE OF 20mm
- MAXIMUM SLUMP OF 100mm

RIP RAP NOTE:
RIP RAP MATERIAL WELL GRADED 125mm TO 150mm HARD, DENSE, ROUNDED & DURABLE FIELD STONE. FILLED JOINTS WITH CEMENT MORTAR.

RIP RAP
CONCRETE
A-BASE

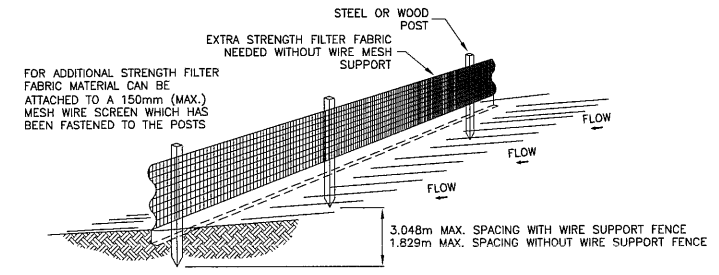

- NOTES:
1. THE HEIGHT OF A SILT FENCE SHALL NOT EXCEED 914mm.
 2. THE FILTER FABRIC SHALL BE PURCHASED IN A CONTINUOUS ROLL CUT TO THE LENGTH OF THE BARRIER TO AVOID THE USE OF JOINTS.
 3. POSTS SHALL BE SPACED A MAXIMUM OF 3.048m APART AT THE BARRIER LOCATION AND DRIVEN SECURELY INTO THE GROUND A MINIMUM OF 300mm. WHEN EXTRA STRENGTH FABRIC IS USED WITHOUT THE WIRE SUPPORT FENCE, POST SPACING SHALL NOT EXCEED 1.829m.
 4. A TRENCH SHALL BE EXCAVATED APPROXIMATELY 100mm WIDE AND 100mm DEEP ALONG THE LINE OF POSTS AND UPSLOPE FROM THE BARRIER.
 5. WHEN STANDARD STRENGTH FILTER FABRIC IS USED, A WIRE MESH SUPPORT FENCE SHALL BE FASTENED SECURELY TO THE UPSLOPE SIDE OF THE POSTS USING HEAVY DUTY WIRE STAPLES AT LEAST 25mm LONG, TIE WIRES, OR HOG RINGS. THE WIRE SHALL EXTEND INTO THE TRENCH A MINIMUM OF 50mm AND SHALL NOT EXTEND MORE THAN 914mm ABOVE THE ORIGINAL GROUND SURFACE.
 6. THE STANDARD STRENGTH FILTER FABRIC SHALL BE STAPLED OR WIRED TO THE FENCE, AND 200mm OF THE FABRIC SHALL BE EXTENDED INTO THE TRENCH. THE FABRIC SHALL NOT EXTEND MORE THAN 914mm ABOVE THE ORIGINAL GROUND SURFACE.
 7. THE TRENCH SHALL BE BACKFILLED AND THE SOIL COMPACTED OVER THE FILTER FABRIC.
 8. SILT FENCING TO BE POLYPROPYLENE SYNTHETIC FIBRE WITH ULTRAVIOLET STABILIZERS. AMOCO 1198 OR APPROVED EQUAL.
 9. WOOD POSTS TO BE 38mm X 89mm (2" X 4"), POINTED AT ONE END AND FABRICATED.
 10. INSTALL ALL SUPPORTING POSTS ON THE DOWN SLOPE SIDE OF THE FENCING.
 11. MAINTAIN SILT FENCE THROUGHOUT CONSTRUCTION AND UNTIL REVEGETATION OCCURS.

6 SILT FENCE DETAIL
SCALE = NTS

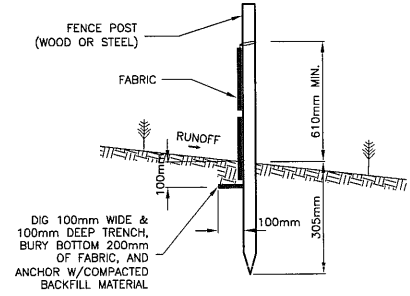

7 SILT FENCE SECTION
SCALE = NTS

8 ATTACHING TWO SILT FENCES
SCALE = NTS

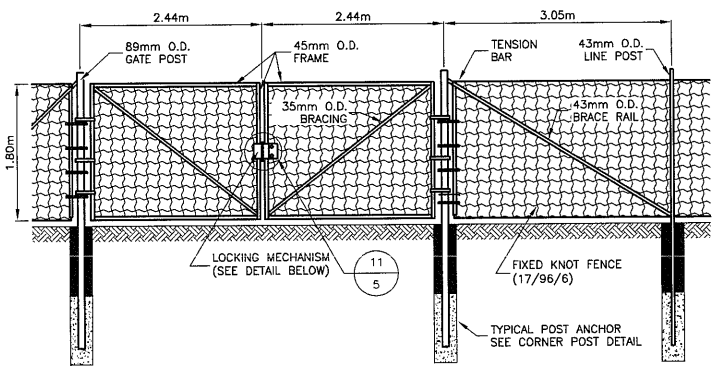

9 GATE DETAIL
SCALE = 1:50

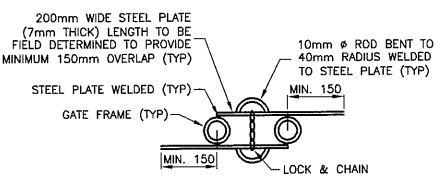

11 LOCK DETAIL
SCALE = 1:10

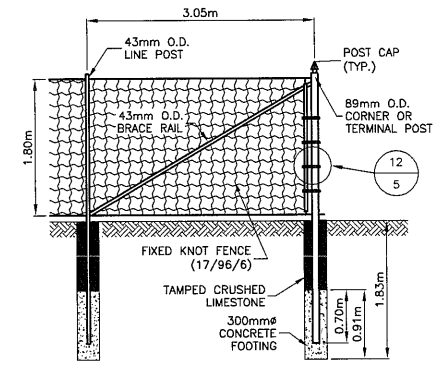

10 CORNER POST
SCALE = 1:50

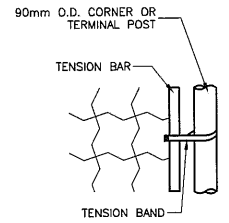

12 TENSION BAR
SCALE = 1:15

PRELIMINARY
NOT FOR CONSTRUCTION

No.	REVISIONS	DATE	INITIALS	B.M. ELEV.

APEGM
Certificate of Authorization
J.R. Cousin Consultants Ltd.
No. 234 Date: 12/10/24

ENGINEER'S SEAL
J.R. COUSIN
REGISTERED PROFESSIONAL ENGINEER
12/10/24



J. R. Cousin Consultants Ltd.
Consulting Engineers and Project Managers
91A Scurlfield Blvd. Winnipeg, MB R3Y 1G4
ph: (204) 489-0474 fax: (204) 489-0487
email: info@jrcc.ca website: www.jrcc.ca
Engineering Excellence since 1981

CODE: S-633.01	PROJECT: SOUTH WHITESHELL PROVINCIAL PARK TRUCKHAUL LAGOON FEASIBILITY STUDY
DESIGNED BY: JC	TITLE: SPILLWAY, TRUCK TRUNAROUND, SILT FENCE, FENCE, GATE AND LOCK DETAILS
DRAWN BY: BM	SCALE: AS NOTED
REVIEWED BY: JC	DATE: 12/10/05
	PLAN: 5
	SHEET: 5 of 5