

P&R #8.194 JRCC  
W-210.25

**RURAL MUNICIPALITY OF WOODLANDS**  
**Environment Act Proposal**  
**for**  
**Woodlands Wastewater Treatment Lagoon**  
**Upgrade**

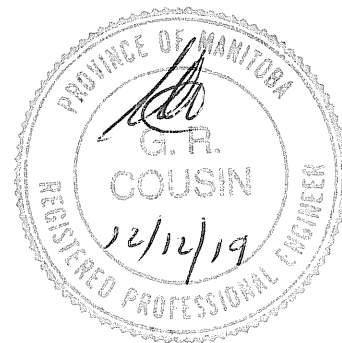
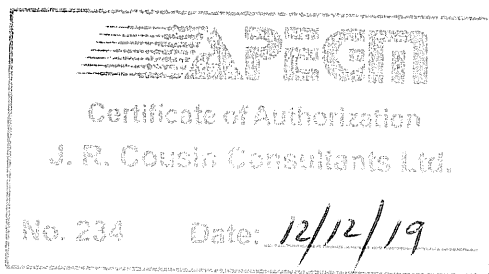

**Prepared by:** J. R. Cousin Consultants Ltd.  
91 A Scurfield Blvd.  
Winnipeg, Manitoba  
R3Y 1G4 Ph. (204) 489-0474

December 2012

## **ACKNOWLEDGMENTS**

To prepare this report various sources of information were investigated and researched. J. R. Cousin Consultants Ltd. (JRCC) wishes to thank the RM of Woodlands and Manitoba Conservation who contributed to the data and content of this study. In addition, we wish to commend the RM of Woodlands for their fortitude in addressing the need for a long-term solution to wastewater treatment for the Community of Woodlands.

## **REMARKS**

J. R. Cousin Consultants Ltd. has conducted this environment act proposal in accordance with generally accepted professional engineering principles and practices for the purpose of identifying conditions that may have an environmental impact on the site. The findings and recommendations reached in this report are based on information made available to JRCC during the investigation and conditions at the time of the site investigation. Conclusions derived in this report are intended to reduce, but not wholly eliminate the uncertainty regarding potential environmental concerns on the site, and recognizes reasonable limitations with regards to time, accuracy, work scope and cost. It is possible that environmental conditions may change from the date of this report. If conditions appear different from those encountered and expressed in this report, JRCC should be informed so that mitigation recommendations can be reviewed and adjusted as required. Historical data and information obtained from personal communication used in this report, are assumed to be correct, however JRCC has not conducted further investigations into the accuracy of this data. JRCC has produced this report for the use of the client, and takes no responsibility for any third party decisions or actions based on information contained in this report.

© Copyright J. R. Cousin Consultants Ltd., 2012

Information contained herein is confidential and may not be released to a third party without express permission of J. R. Cousin Consultants Ltd.

## TABLE OF CONTENTS

Section	Page of Section
<b>ENVIRONMENT ACT PROPOSAL FORM</b>	
<b>1.0 INTRODUCTION AND BACKGROUND .....</b>	<b>1</b>
1.1 Introduction .....	1
1.2 Contact Information .....	1
1.3 Background Information .....	1
1.4 Description of Previous Studies .....	2
<b>2.0 DESCRIPTION OF THE DEVELOPMENT .....</b>	<b>1</b>
2.1 Land Title/Location .....	1
2.2 Owner of Land and Mineral Rights .....	1
2.3 Existing Land Use .....	1
2.4 Land Use Designation/Zoning Designation .....	2
2.5 Description of Development.....	2
2.5.1 Project Schedule .....	2
2.5.2 Basis for Proposed Lagoon Expansion Site Selection.....	2
2.5.3 Lagoon Drainage Route.....	3
2.5.3.1 Fish Species Information .....	4
2.5.3.2 Water Quality Information.....	4
2.5.4 Access Road .....	5
2.5.5 Population Contributing Effluent .....	5
2.5.5.1 Community of Woodlands .....	5
2.5.5.2 Mobile Home Park .....	5
2.5.5.3 School .....	5
2.5.5.4 Rural Residents .....	6
2.5.5.5 Population Projections to Design Year 26 and 44 .....	6
2.5.5.6 Population Summary Table.....	6
2.5.6 Wastewater Production.....	7
2.5.6.1 Organic Loading .....	7
2.5.6.2 Hydraulic Loading .....	8
2.5.7 Lagoon Sizing Requirements .....	8
2.5.7.1 Primary Cell .....	8
2.5.7.2 Storage Cells .....	9
2.5.8 Topography and Geotechnical Review .....	10
2.5.8.1 Past Geotechnical Investigations.....	10
2.5.8.2 Current Geotechnical Investigation.....	11
2.5.8.3 Topography .....	13
2.5.9 Lagoon Regulatory Requirements.....	13
2.5.9.1 Province of Manitoba Design Objectives .....	13
2.5.9.2 Nutrient Management Plan .....	14
2.5.10 Summarized Selected Design Criteria.....	16
2.5.11 Lagoon Layout .....	18

<b>Section</b>	<b>Page of Section</b>
2.5.12 Lagoon Construction Detail .....	18
2.5.12.1 General, Conceptual Liner Design and Construction Techniques .....	18
2.5.12.2 Construction Details.....	20
2.5.13 Decommissioning.....	20
2.5.14 Lagoon Maintenance .....	21
<b>3.0 POTENTIAL ENVIRONMENTAL IMPACTS.....</b>	<b>1</b>
3.1 Releases to Air, Water, Land.....	1
3.1.1 Air.....	1
3.1.2 Water .....	1
3.1.3 Land.....	2
3.2 Wildlife.....	2
3.3 Fisheries .....	3
3.4 Forestry.....	3
3.5 Vegetation .....	3
3.6 Noise Impacts.....	3
3.7 Health and Safety .....	3
3.8 Heritage Resources.....	3
3.9 Socio-Economic Implications .....	4
3.10 Aesthetics .....	4
<b>4.0 MANAGEMENT PRACTICE .....</b>	<b>1</b>
4.1 Mitigation of Impacts to Air.....	1
4.2 Mitigation of Impacts to Water .....	1
4.2.1 Surface Water.....	1
4.2.2 Groundwater.....	3
4.3 Mitigation of Impacts to Land.....	3
4.4 Mitigation of Noise Impacts.....	3
4.5 Mitigation of Impacts to Health and Safety .....	3
4.6 Mitigation of Impacts to Heritage Resources.....	4
<b>5.0 RESIDUAL AND CUMULATIVE EFFECTS .....</b>	<b>1</b>
<b>6.0 MONITORING AND FOLLOW-UP .....</b>	<b>1</b>
<b>7.0 FUNDING AND APPROVALS.....</b>	<b>1</b>
<b>8.0 PUBLIC CONSULTATION.....</b>	<b>1</b>
<b>9.0 CONCLUSION .....</b>	<b>1</b>

**Appendix A**

Land Titles Transactions (Instrument Number 2744813)

Land Title (Number 1989566/1)

Crown Lands & Property Agency - Lands Branch, December 4, 2012 Email Correspondence

## **Appendix B**

Table 1: Community of Woodlands Population, Hydraulic, and Organic Loading Projections

Manitoba Conservation and Water Stewardship Fisheries Branch, November 23, 2012 Email Correspondence

Manitoba Conservation Wildlife and Ecosystem Protection Branch, November 29, 2012 Email Correspondence

Manitoba Historic Resources Branch, December 11, 2012 Memorandum

## **Appendix C**

Test Hole Logs

National Testing Laboratories Soils Analysis Results

Driller's Well Logs

## **Appendix D**

Title Page

Plan L1: Proposed Lagoon Expansion Location Plan with Setbacks

Plan L2: Proposed Lagoon Expansion Layout with Test Hole Locations

Plan L3: Lagoon Discharge Route

Plan L4: Perimeter Dike and Transition Area

Plan L5: Lagoon Section West to East

Plan L6: Lagoon Section North to South

Plan L7: Valve, Valve Marker, Sign, Rip Rap, Ditch and Silt Fence Details

Plan L8: Spillway, Truck Turnaround, Fence, Gate and Lock Details

# Environment Act Proposal Form

Name of the development: RM of Woodlands Wastewater Treatment Lagoon Upgrade	
Type of development per Classes of Development Regulation (Manitoba Regulation 164/88): Wastewater Treatment Lagoon - Class 2 Development	
Legal name of the proponent of the development: R.M. of Woodlands	Mailing address: RM of Woodlands Box 10 Woodlands, MB., R0C 3H0
Location (street address, city, town, municipality, legal description) of the development: SE 23-14-2 WPM	
Name of proponent contact person for purposes of the environmental assessment: Mr. Jerry Cousin	
Phone: (204) 489-0474 Fax: (204) 489-0487	Mailing address: J.R. Cousin Consultants Ltd. 91 A Scurfield Blvd. Winnipeg, MB, R3Y 1G4
Email address: jcousin@jrcc.ca	
Webpage address: www.jrcc.ca	
Date: <i>Dec 19/2012</i>	Signature of proponent, or corporate principal of corporate proponent:  Printed name: Jerry Cousin

A complete **Environment Act Proposal (EAP)** consists of the following components:

- **Cover letter**
- **Environment Act Proposal Form**
- **Reports/plans supporting the EAP** (see "Information Bulletin - Environment Act Proposal Report Guidelines" for required information and number of copies)
- **Application fee** (Cheque, payable to Minister of Finance, for the appropriate fee)

**Submit the complete EAP to:**

Director  
Environmental Assessment and Licensing Branch  
Manitoba Conservation  
Suite 160, 123 Main Street  
Winnipeg, Manitoba R3C 1A5

**For more information:**

Phone: (204) 945-7100  
Fax: (204) 945-5229  
Toll Free: 1-800-282-8069, ext. 7100  
<http://www.gov.mb.ca/conservation/eal>

Per Environment Act Fees Regulation (Manitoba Regulation 168/96):	
Class 1 Developments .....	\$500
Class 2 Developments .....	\$5,000
Class 3 Developments:	
Transportation and Transmission Lines.....	\$5,000
Water Developments .....	\$50,000
Energy and Mining.....	\$100,000

## **1.0 INTRODUCTION AND BACKGROUND**

The development described herein is for upgrading the existing Woodlands Wastewater Treatment Lagoon in the RM of Woodlands, Manitoba.

### **1.1 Introduction**

The RM of Woodlands is proposing to upgrade the existing wastewater treatment lagoon for the Community of Woodlands through expansion. A lagoon expansion is required to accommodate the future proposed growth in the community. An Environment Act Licence is required from Manitoba Conservation for the construction and operation of the upgraded lagoon. J. R. Cousin Consultants Ltd. (JRCC) was retained for the related engineering services.

### **1.2 Contact Information**

Mr. Jerry Cousin, P.Eng.  
J. R. Cousin Consultants Ltd.  
91A Scurfield Blvd.  
Winnipeg, Manitoba  
R3Y 1G4  
Phone (204) 489-0474, Fax (204) 489-0487

Ms. Lynn Kauppila  
Chief Administrative Officer  
RM of Woodlands  
Woodlands, Manitoba  
R0C 3H0

### **1.3 Background Information**

The Community of Woodlands is located approximately 45 km northwest of Winnipeg, Manitoba along PTH #6. The existing lagoon is located in SE ¼ 23-14-2 WPM. The in-town residents, school students/staff and mobile home residents contribute to the lagoon loading, via a piped wastewater collection system. The surrounding rural residents use septic tanks and contribute to the lagoon loading via septic truck hauling.

The Woodlands lagoon was constructed in the early 1990's, with the construction of a primary cell and a secondary cell of re-worked clay soils. The lagoon is currently being operated under Environmental Licence No. 1563, issued in 1992. Based on a recent expansion within the community, the wastewater treatment lagoon is in need of upgrading, therefore a new environmental licence would be required.

## 1.4 Description of Previous Studies

Various sources of information for the Woodlands lagoon were reviewed to obtain background information on the site. A geotechnical investigation was completed by JRCC in 1990 at the current site of the Woodlands lagoon, as part of the lagoon siting study. Four test holes were completed at the lagoon site to a maximum depth of 4.6 m. The soils consisted of surficial topsoil (0 m - 0.3 m), followed by a layer of silty, sandy clay (0.3 m - 1.2 m), followed by silty clay (1.2 m – 4.6 m). Information from previous studies by others indicates the soil stratigraphy in the location of the lagoon consists of clay underlain by glacial till with a few pockets of sand and gravel over carbonate bedrock.

The Woodlands lagoon EAP prepared by JRCC in 1991 was reviewed to determine environmental conditions and concerns at the time of the original lagoon construction. This EAP identified the lagoon as having a 20 year design life, with a design population of 469 people and a hydraulic storage capacity for 200 days. No significant environmental or health and safety concerns were anticipated at the time of the lagoon construction.

The “Record Drawings” of the Woodlands lagoon construction (by JRCC, 1991) were reviewed to determine the method of lagoon construction, and to assess the current lagoon sizing.

The *Feasibility Study for the RM of Woodlands Wastewater Treatment Lagoon Upgrading* by JRCC, October 2012 was utilized to establish a conceptual design for the lagoon expansion. Various options for expansion were discussed, a geotechnical and topographical investigation of the site was conducted and cost estimates were provided.



## **2.0 DESCRIPTION OF THE DEVELOPMENT**

For each heading there is an information request from the Environment Act Proposal Form. These requests are repeated herein in italics followed by the pertaining response.

### **2.1 Land Title/Location**

*Certificate of Title showing the owner(s) and legal description of the land upon which the development will be constructed; or, in the case of highways, rail lines, electrical transmission lines, or pipelines, a map or maps at a scale no less than 1:50,000 showing the location of the proposed development:*

The existing lagoon is located in legal plan no. 29104 WLTO in SE ¼ 23-14-2 WPM. The proposed lagoon expansion to the east will be partially in legal plan no. 29104 WLTO and partially to the east, still within SE ¼ 23-14-2 WPM. A copy of the Land Titles Transaction (Winnipeg – 1888254) for the land on which the existing lagoon was constructed is attached in Appendix A, along with the Certificate of Title (No. 1989566/1) for the land which the RM of Woodlands intends on purchasing for the proposed lagoon expansion.

### **2.2 Owner of Land and Mineral Rights**

*Owner of land upon which the development is intended to be constructed, and of mineral rights beneath the land, if different from surface owner:*

The Crown Lands & Property Agency was contacted regarding the proposed development location. According to the Crown Lands & Property Agency, the mines and minerals and sand and gravel at the existing and proposed lagoon site are privately owned with the surface titles. (see email correspondence from the Crown Lands & Property Agency, dated December 4, 2012 in Appendix A). The Municipality currently owns the existing lagoon site and is in the process of purchasing the land required for expansion.

### **2.3 Existing Land Use**

*Existing land use on the site and on land adjoining it, as well as changes that will be made in such land use for the purposes of the development:*

The proposed lagoon expansion site is the land directly east of the existing lagoon cells, and is currently being used for agricultural purposes. The surrounding lands adjacent to the site are all agricultural fields with a municipal road bordering the site to the south, while the town is located approximately 1.7 km to the northwest of the existing lagoon (see Plan 1 in Appendix D).

Soil would be excavated in the area of the proposed lagoon expansion for construction of the lagoon dikes and drainage ditches. The existing access road would continue to be utilized, which connects to Railway Ave. in the Community of Woodlands.

## 2.4 Land Use Designation/Zoning Designation

*Land use designation for the site and adjoining land as identified in a development plan adopted under The Planning Act or The City of Winnipeg Act, and the zoning designation as identified in a zoning by-law, if applicable:*

The lagoon expansion site is zoned as Agricultural General, based on zoning designations in the RM of Woodlands.

## 2.5 Description of Development

*Description of proposed development and schedule for stages of the development, including proposed dates for planning, design, construction, commissioning, operation, and decommissioning and/or termination of operation (if known), identifying major components and activities of the development as applicable (e.g. access road, airstrip, processing facility, waste disposal area, etc.).*

### 2.5.1 Project Schedule

Lagoon design is proposed to begin upon receipt of an environmental licence. Lagoon construction works are proposed to begin in the summer of 2013, dependent upon approval of funding. Commissioning and operation of the lagoon is proposed to begin upon completion of construction and after approval for use is obtained from Manitoba Conservation. No date for decommissioning has been set for the lagoon.

### 2.5.2 Basis for Proposed Lagoon Expansion Site Selection

The location for lagoon expansion was chosen based on discussions with the project team, proximity to the existing community (as discussed below) and proximity to the existing RM property boundaries.

Manitoba Conservation's guidelines for the location of a wastewater treatment lagoon (Design Objectives for Standard Sewage Lagoons, Province of Manitoba, Environmental Management, July 1985) are outlined in the following table. A description of the proposed site in relation to each of the guidelines is also provided in the table.

**Table A: Location of Proposed Lagoon Upgrade Sites in Relation to Manitoba Conservation Guidelines**

Manitoba Conservation Guideline	Proposed Relation to Site
Lagoons must be located a minimum of 460 m from any community centre.	The proposed lagoon expansion site is located approximately 1.7 km from the Community of Woodlands town site.

<b>Manitoba Conservation Guideline</b>	<b>Proposed Relation to Site</b>
Lagoons must be located a minimum of 300 m from any residence. (The distance is to be measured from the centreline of the nearest dike).	The proposed lagoon expansion site is located approximately 680 m from the nearest resident.
Consideration should be given to sites in which prevailing winds are in the direction of uninhabited areas.	The prevailing winds are typically from the north and west. The proposed lagoon expansion site is located southeast of the community.
Sites with an unobstructed wind sweep across the lagoon are preferred.	The surrounding land is open agricultural land with no nearby windbreaks.
Areas that are habitually flooded shall be avoided.	The lagoon is situated approximately 22 km from the Assiniboine River and flooding is not expected in the area. The top of dikes of the proposed lagoon expansion cell would be constructed at approximately 0.5 m higher than the top of dikes of the existing lagoon. There have been no reports of flooding around the existing lagoon cells.
Areas of porous soils and fissured rock formations should be critically evaluated to avoid creation of health hazards or other undesirable conditions.	A liner will be utilized in the lagoon expansion cell construction according to Provincial guidelines, thus reducing the possibility of groundwater contamination.

The lagoon expansion area is located beyond all setback distances required by Manitoba Conservation, therefore there are no expected concerns for the location of the expansion cell. Plan 1 in Appendix D, shows the minimum setback distance requirements for the upgraded lagoon to the local residents and community.

### **2.5.3 Lagoon Drainage Route**

The Woodlands lagoon effluent discharge is currently to the south, towards East Branch Sturgeon Creek (3<sup>rd</sup> Order Drain), via the lagoon perimeter ditch and the Municipal Road ditch. East Sturgeon Creek eventually merges into Sturgeon Creek (4<sup>th</sup> Order Drain) which empties into the Assiniboine River. The total length of the drainage route is approximately 45 km prior to reaching the Assiniboine River (see Plan 3 in Appendix D). The design of the lagoon expansion will continue to utilize this drainage path for lagoon effluent discharge. The converted Storage Cell #2 will include an independent discharge

valve to the west of the lagoon cell, which will empty into the perimeter ditch and flow south into the existing discharge route.

### 2.5.3.1 Fish Species Information

The following fish species have been identified in East Branch Sturgeon Creek according to the Fisheries Inventory Habitat and Classification System (FIHCS): fathead minnows and brook stickleback. The following fish species have been identified in Sturgeon Creek according to FIHCS: Yellow perch, black bullheads, black crappie, blacknose dace, blacknose shiner, bluntnose minnow, brown bullhead, carp, central mudminnow, channel catfish, creek chub, emerald shiner, fathead minnow, flathead chub, freshwater drum, golden redhorse, golden shiner, goldeye, northern pike, walleye, white sucker, brook stickleback, common shiner, Johnny darter, log perch, longnose dace, mooneye, quillback, river shiner, rock bass, sauger, shorthead redhorse, silver chub, silver lamprey, silver redhorse, slimy sculpin, sand shiner, stonecat, tadpole madtom, trout perch and spottail shiner. Sturgeon Creek is a fished recreationally and provides spawning, rearing and foraging habitat (see November 23, 2012 email correspondence from Manitoba Conservation and Water Stewardship – Fisheries Branch).

### 2.5.3.2 Water Quality Information

Manitoba Conservation and Water Stewardship were contacted for water quality data in Sturgeon Creek. Summarized water quality data from selected parameters are provided below. Samples were retrieved from the nearest monitoring station to the lagoon site (No. MB05MJS052), which is located at Sturgeon Creek and PTH #323. The samples were recorded between June and August of 2000 and May of 2012.

**Table B: Average Water Quality in the Sturgeon Creek**

Parameter	Average Concentration	Unit
Ammonia Dissolved	0.02	mg/L
Coliforms Fecal	223	CFU/100ML
Nitrogen Dissolved NO <sub>3</sub> & NO <sub>2</sub>	0.01	mg/L
Nitrogen Total Kjeldahl (TKN)	1.5	mg/L
Biochemical Oxygen Demand	1.0	mg/L
Oxygen Dissolved	2.2	mg/L
Phosphorus Total (P)	0.09	mg/L
Total Dissolved Solids (TDS)	440	mg/L @ 105C
Total Suspended Solids (TSS)	<5.00*	mg/L

\*Parameters below the detectable limit were assumed to be at the detectable limit for the purposes of averaging.

Based on the average concentrations shown in Table 2.2, Sturgeon Creek has naturally low nutrient levels (phosphorus and nitrogen).

#### **2.5.4 Access Road**

The upgraded lagoon site would continue to be accessed by an all weather municipal road bordering the site to the south. This is an existing road which can be used to access the Community of Woodlands. An extension to the existing truck turnaround area will be constructed, to provide access to the new spillway in the primary cell.

#### **2.5.5 Population Contributing Effluent**

Population data was obtained from the RM of Woodlands for the service area utilizing the Woodlands lagoon. This includes residents within the Community of Woodlands, the Woodlands Mobile Home Park, the Woodlands Elementary School and rural residents in the surrounding RM.

##### **2.5.5.1 Community of Woodlands**

From discussions with the RM, the community has 99 buildings currently connected to the sewer system and it was estimated that the average number of people per household in the community is 4. This would result in a current population of 396 people in the Community of Woodlands. Based on the proposed development in the area, it was estimated that an additional 50 residential lots would be constructed over the next 20 years, which would relate to a growth rate of approximately 2.1% per year. Therefore the village would have a year 20 population of 596 people.

##### **2.5.5.2 Mobile Home Park**

There are currently 14 mobile homes in the mobile home park with an estimated average population of 2.5 people per home. This would result in a total population of 35 people in the mobile home park. The RM has indicated that there is very limited potential for expansion, therefore it was assumed that the mobile home park would have a growth rate of 0.5% over 20 years. Therefore the total year 20 population for the mobile home park would be 38 people.

##### **2.5.5.3 School**

The Woodlands Elementary School was contacted for information on the contributing population from bussed in students, which would contribute additional loading to the lagoon. There are 125 total students at the school, with approximately 85% of the students bussed in, i.e. 106 people. The population of bussed in students would have an assumed occupancy of 1/3 the population, based on the amount of time spent at school, and would therefore

represent an equivalent population of 35 full time residents with a 0.0% growth rate.

#### 2.5.5.4 Rural Residents

Additional wastewater loading from other sources would include a small population from the surrounding rural areas. From discussions with the RM, approximately 100 residences (400 people, based on 4 people per household) would be considered for truck hauling to the lagoon from the surrounding rural community. Septic tanks with pump outs every year were assumed for these rural residents. This rural population is not expected to grow in the next 20 years, therefore a growth rate of 0.0% will be utilized.

#### 2.5.5.5 Population Projections to Design Year 26 and 44

Typically a lagoon upgrade will be sized for a 20 year period, however as described in Section 2.5.6 below, the upgraded lagoon is proposed to be sized for design year 26 hydraulic loadings and design year 44 organic loadings. Therefore, projected populations of these design years have also been included in the summary table below and in the attached Table 1.

#### 2.5.5.6 Population Summary Table

Contributing Population	Current Population	Year 20 Population	Year 26 Population	Year 44 Population
Community of Woodlands	396	596	674	973
Woodlands Mobile Home Park	35	38	40	43
Woodlands School "Bussed in" Students (equivalent population)	35	35	35	35
Rural Residents in Surrounding RM	400	400	400	400

Table 1, attached in Appendix B, shows the current and projected year 20, year 26 and year 44 service populations, along with the projected wastewater loadings.

**Summary:** The total projected year 20 equivalent population utilized for design purposes in the lagoon upgrading is 669 people (piped population) and 400 people (truck hauled population). The total projected year 26 equivalent population utilized for design

purposes in the lagoon upgrading for hydraulic loading is 749 people (piped population) and 400 people (truck haul population). The total projected year 44 equivalent population utilized for design purposes in the lagoon upgrading for organic loading is 1,051 people (piped population) and 400 people (truck haul population).

## **2.5.6 Wastewater Production**

### **2.5.6.1 Organic Loading**

The organic loading calculation is based upon the organics in typical residential wastewater and septage. A typical value of 0.076 kg BOD<sub>5</sub>/person/day was utilized to estimate the organic loading from the residents and school population within the community, through the piped collection system. The organic loading from septage considers concentrations of both septage “sludge” and septage effluent, found in truck hauled septage. For the Woodlands lagoon, the truck hauled septage impacts the peak BOD loading per day, which needs to be considered in lagoon sizing.

The current daily organic loading from piped sources in the community is approximately 35.4 kg BOD<sub>5</sub>/day (i.e. 466 people x 0.076 kg BOD<sub>5</sub>/person/day). These daily loadings are expected to increase to 50.8 kg BOD<sub>5</sub>/day (i.e. 669 people x 0.076 kg BOD<sub>5</sub>/person/day) in year 20, due to the increase in residential population.

The truck hauled septage from rural septic tanks, is considered for a peak daily BOD loading, as this affects the odours generated at the lagoon during disposal. The truck hauled septage to the lagoon should be limited to one truck load (13,500 L) per day by the RM. At a typical strength for septage sludge of 0.007 kg BOD<sub>5</sub>/L, and a typical strength of septage effluent of 0.000264 kg BOD<sub>5</sub>/L, the organic loading for one truck load of septage would be 20.1 kg BOD<sub>5</sub>/day. Due to the inclusion of one truck load of septage per day to account for peak organic loading, a safety factor has been built into the lagoon design, since each of the rural septic tanks will not necessarily be pumped out every year, and therefore, there will not likely be one truckload of septage hauled to the lagoon each day.

Therefore, the total current organic loading to the lagoon would be approximately 55.5 kg BOD<sub>5</sub>/day (20.1 kg BOD<sub>5</sub>/day + 35.4 kg BOD<sub>5</sub>/day) and the total projected year 20 organic loading to the lagoon would be approximately 70.9 kg BOD<sub>5</sub>/day (20.1 kg BOD<sub>5</sub>/day + 50.8 kg BOD<sub>5</sub>/day). As discussed below in section 2.5.7.1, the primary cell is being sized for a daily organic loading of 100.1 kg BOD<sub>5</sub>/day in design year 44. Table 1 in Appendix

B shows the current and projected year 20, year 26 and year 44 organic loadings to the lagoon.

### **2.5.6.2 Hydraulic Loading**

The hydraulic loading to the wastewater treatment lagoon is comprised of three waste streams: water usage, infiltration and truck hauled septage. The wastewater conveyed by the wastewater collection system includes both water usage and infiltration. The per capita wastewater production identified for the community was 258 L/person/day, based off of average lift station pumping records. The current Manitoba Regulations require a lagoon to have sufficient storage for a 230 day period over the winter months.

The volume of wastewater generated from the rural residents truck hauled septage, is based off a typical septic tank volume and a pump out once every year, which was reported from local septic haulers. Truck hauling septage to the lagoon is not permitted between October 15 and June 1 (230 days). The per capita wastewater production for septic tank users was estimated to be 200 L/person/year.

The total hydraulic loading to the lagoon from all sources would be 173 m<sup>3</sup>/day in design year 20. The total hydraulic capacity of the lagoon would need to be 39,880 m<sup>3</sup> over the required 230 day storage period. As discussed in section 2.5.7.2 below, the lagoon cells were sized for a hydraulic storage capacity of 44,563 m<sup>3</sup>, which is sufficient to design year 26. Table 1 in Appendix B shows the current and projected year 20 and year 26 hydraulic loadings to the lagoon.

## **2.5.7 Lagoon Sizing Requirements**

The upgraded lagoon would consist of one new primary cell and two storage cells, each with 4:1 inner and outer side slopes. The operating depths, freeboard and discharge inverts are described below.

The lagoon will be sized to handle the year 20 organic and hydraulic loadings from the community and rural populations, as discussed above.

### **2.5.7.1 Primary Cell**

A facultative lagoon operates at various organic efficiencies throughout the year with the commonly accepted organic treatment rate being 56 kg BOD<sub>5</sub>/ha/day, at a height of 0.75 m in the lagoon primary cell. At this treatment rate, the minimum required surface area at a height of 0.75 m from the floor in the primary cell would be approximately 12,661 m<sup>2</sup> (i.e. 70.9/56 x 10,000), considering the year 20 projected organic loading rate of approximately 70.9 kg BOD<sub>5</sub>/day.



However, in designing the new primary cell, consideration was also given to the overall hydraulic storage requirements of the existing lagoon cells (storage cells #1 and #2). From this review, it was determined that an oversized primary cell would provide the required year 20 hydraulic storage capacity for the lagoon, without the added cost of constructing of an additional storage cell. By oversizing the primary cell for 20 year hydraulic capacity, the organic capacity of the primary cell would be increased to design year 44, assuming one truck load of septage per day. The surface area of the proposed primary cell at a height of 0.75 m from the cell floor would be 17,867 m<sup>2</sup>, and could accept a daily organic load of 100.6 kg BOD<sub>5</sub>/day.

The primary cell flat bottom area would be 213 m x 76 m and designed with a maximum operating level of 1.5 m and a freeboard of 1.0 m, as per Manitoba Conservation requirements.

#### **2.5.7.2 Storage Cells**

The storage capacity of a facultative lagoon is calculated by the combined volume of the “top half” of the primary cell (liquid storage from 0.75 m depth to 1.5 m depth) and the volume of the storage cell from the discharge pipe invert elevation to the maximum liquid level. The required hydraulic storage requirement during the 230 day period from November 1 to June 14, for year 20 hydraulic loadings would be approximately 39,880 m<sup>3</sup>. The hydraulic storage capacity of storage cells #1 and #2 would be approximately 30,407 m<sup>3</sup>, while the remaining hydraulic capacity (9,473 m<sup>3</sup>) would come from the top half of the primary cell.

The existing lagoon cells (proposed storage cells) were originally constructed with a total depth of 2.25 m from the cell floor to top of dike and an operating depth of 1.5 m. Through discussions with the design team it was recommended that the existing dikes be raised in the proposed storage cells to increase the operating depth to 1.7 m. This would be accomplished by raising the existing top of dikes by 0.45 m, to a total height of 2.7 m above the cell floor. This option of raising the existing dikes was discussed and confirmed as being viable with Manitoba Conservation Licencing Branch. As the proposed new primary cell would have a top of dike elevation approximately 1.0 m above the existing lagoon cells (due to the location of suitable liner material and excavation quantities, as discussed in section 2.5.12.1 below), raising the existing top of dikes and operating depth in the storage cells would reduce the elevation differences between the lagoon cells. The proposed cut-off wall and dikes of the primary cell will tie into the existing lagoon dikes, creating an elevation difference between the primary and storage cells. Therefore, raising the existing dikes will reduce the elevation difference between the two cells, which

will simplify lagoon maintenance and operation for the RM. The lagoon would have a total hydraulic storage capacity of 44,563 m<sup>3</sup>, and would increase the hydraulic capacity of the lagoon to design year 26.

The proposed operating depth of the storage cells would be 1.7 m, with the discharge pipes located at 0.15 m above the cell floor elevation in storage cell #1 and 0.3 m above the cell floor elevation in storage cell #2. The discharge pipe in storage cell #1 is existing, while the discharge pipe in storage cell #2 is proposed. By raising the existing dikes, the freeboard in the storage cells will be raised to 1.0 m.

Typical operation of the storage cell in a facultative lagoon will allow for two discharges per year at peak design loading. During operation of the lagoon at peak design loading, the intercell valve would be opened after fall discharge of the lagoon and allowed to fill up from winter and spring loadings. Prior to June 15, the intercell valve would be closed and the storage cell effluent would be tested for the discharge criteria. If the test results are acceptable, the storage cell volume from the discharge pipe invert elevation to the maximum operating level would be discharged starting on June 15<sup>th</sup>. Once the storage cell is fully discharged, the intercell valve could be opened and the lagoon cells would be allowed to equalize. The intercell valve would remain open and both lagoon cells would be allowed to fill up from summer hydraulic loadings. The intercell valve would again be closed and the storage cell effluent would be tested for the discharge criteria. If test results are acceptable, the storage cells could be discharged while the primary cell would accept hydraulic loadings to the lagoon during the discharge period. This final discharge would occur prior to the end of the discharge period, before October 31<sup>st</sup>. This discharge procedure would be repeated each year.

The existing lagoon cells (proposed storage cell #1 and #2) would have a flat bottom area of approximately 122 m x 90 m, and 71 m x 90 m respectively. These cells will be designed and operated with a freeboard of 1 m above the maximum operating level, as per Manitoba Conservation requirements.

## **2.5.8 Topography and Geotechnical Review**

### **2.5.8.1 Past Geotechnical Investigations**

#### *GW Driller's Well Logs*

Two well log reports in the vicinity of 23-14-2 WPM were available from Manitoba Water Stewardship. These reports indicated that the subsoils in the area consist of surficial gravel fill, followed by clay, which extends 3 m to 6 m below the surface, followed by boulders, till and limestone to the bottom of the

boreholes (approximately 53 m below the surface). Groundwater was reported at depths ranging from 2.7 m to 22 m below the surface.

### *Canada-Manitoba Soil Survey*

Reconnaissance Soils Survey data of the area indicated that the soils consist of Lakeland fine sandy loams in the vicinity of the existing lagoon. These are classified as shallow soils on fine sandy lacustrine deposits. Detailed soil survey information was not available for the project area.

## **2.5.8.2 Current Geotechnical Investigation**

An on-site geotechnical and topographic investigation was completed by JRCC on June 14, 2012 to determine the suitability of the site for the proposed lagoon expansion.

### *Test Holes*

Six test holes were excavated during the geotechnical investigation to a maximum depth of 5.5 m. The test holes were excavated on all sides of the existing lagoon to determine whether the soils were suitable for use as an in-situ clay liner, and whether soils could be used for potential borrow material. Test hole locations are shown on Plan 2 of Appendix D.

### *Soil Profile*

From the six test holes excavated around the existing lagoon cells, the soil profile was fairly consistent between test holes to the east and north. The test holes to the west (TH5 and TH6) varied considerably. The soils to the west of existing lagoon cells appeared to have been altered through previous construction earthwork, likely during the original lagoon construction.

The native soil profile to the east and north of the existing lagoon cells consisted of organic topsoil (0.3 m thick), followed by a layer of low plastic silty clay (approximately 0.4 m thick). Below the silty clay was a layer of fine grain sand (approximately 0.4 m thick), followed by a layer of high plastic clay till (approximately 1.4 m thick), and finally a sandy clay till down to the bottom of the test holes.

Details of the soil profile in each test hole can be found in the test hole logs, attached in Appendix C.

### *Groundwater and Bedrock*

Groundwater was encountered in some of the test holes (TH1, TH4 and TH5) at depths ranging from 0.6 m to 3.6 m below ground surface. Sloughing of test

holes was also encountered in the test holes with water infiltration. Groundwater in the test holes depends on high static groundwater conditions and on seasonal conditions, i.e. snowmelt and rainy seasons. Other assumptions relating to the groundwater elevation cannot be made at this time, as water levels will normally fluctuate seasonally.

Bedrock was not encountered in any of the test holes, however rocks were encountered throughout the soil profile in all of the test holes on the north and east sides. Details of the groundwater depth and sloughing depth for each test hole can be found in the attached test hole logs, in Appendix C.

### *Laboratory Analysis*

Two bagged soil samples were submitted to National Testing Laboratories Ltd. (NTL) for analysis. The analysis included measurements of the Atterberg Limits, Particle Size Analysis, Moisture Content and Visual Soil Classification. One Shelby tube sample was also submitted for analysis of hydraulic conductivity of in-situ soil material. The samples were analyzed to determine whether the soils observed at the site would be suitable for the construction of a cell liner in accordance with the Provincial regulations for permeability.

JRCC requested that the laboratory provide a professional assessment, based on the analysis and the testing, as to whether the soil samples could achieve a permeability of  $1 \times 10^{-7}$  cm/sec or less in their in-situ and re-compacted states. A summary of the laboratory results are as follows:

The laboratory results of the bagged samples indicated that the soils consisted of low plastic sandy clay to high plastic clay. From past experience the lab indicated that homogeneous soils with a plasticity index greater than 25 and clay content greater than 50% will typically have a hydraulic conductivity of  $1 \times 10^{-7}$  cm/sec or less. The high plastic clay sample submitted had a plasticity index of 42 and a clay content of 70%. It is therefore expected that the high plastic clay soil would achieve a permeability of less than  $1 \times 10^{-7}$  cm/sec, with or without being re-worked, which would be suitable for construction of a soil liner. However, these results are dependent on the soils being homogeneous with no preferential flow paths, such as fissuring. The sample of low plastic sandy clay soil submitted had a plasticity index of 17 and a clay content of 35%, therefore would likely not achieve a permeability of less than  $1 \times 10^{-7}$  cm/sec.

The laboratory results of the Shelby tube sample indicated that the in-situ soil had a hydraulic conductivity of  $9.2 \times 10^{-9}$  cm/sec. This sample was extracted from the high plastic clay layer described above.

Details of National Testing Laboratories test results and analysis, dated July 23, 2012 have been included in Appendix C.

### ***Discussion***

Manitoba Conservation guidelines require a standard wastewater lagoon clay liner to be a minimum of 1.0 m in thickness and have a maximum hydraulic conductivity (i.e. the potential rate of fluid movement through the soil) of  $1 \times 10^{-7}$  cm/sec or less. This low rate is to protect the underlying groundwater from lagoon seepage.

Based on the results of the onsite investigation and laboratory analysis, there is a layer of high plastic soils throughout the lagoon expansion area which would be suitable for use in-situ as a lagoon liner. This layer of high plastic clay varies from 1.3 m to 1.5 m in thickness throughout the expansion area, which is reasonable to utilize in liner construction. This soil layer would be suitable for a horizontal liner assuming it is homogeneous throughout, with no preferential flow paths. If however, a pocket or seam of unsuitable material was discovered during construction, this unsuitable soil would be removed and replaced with re-compacted suitable clay soil.

### **2.5.8.3 Topography**

The topography surrounding the existing Woodlands lagoon was obtained through a GPS survey of the expansion area during the site investigation. From the topographical investigation, the site is relatively flat with a maximum elevation difference of 0.84 m across the site, with a gentle slope to the south. The average elevation across the expansion area to the east is 251.92 m (ASL). The only surface water observed was in the perimeter ditches surrounding the lagoon, while the remainder of the site was dry.

## **2.5.9 Lagoon Regulatory Requirements**

### **2.5.9.1 Province of Manitoba Design Objectives**

The Province of Manitoba Design Objectives for Standard Sewage Lagoons, were used as a guideline in the layout and design of the lagoon expansion.

### ***Organic Loading***

Although a facultative lagoon operates at various organic efficiencies throughout the year, an average organic treatment capacity of 56 kg BOD<sub>5</sub>/ha/day at a depth of 0.75 m in the primary cell has been utilized for design purposes.

### ***Hydraulic Loading***

According to current guidelines a facultative lagoon cannot be discharged between November 1 and June 15 (230 day winter storage period). Therefore, the lagoon must have the storage capacity for this time period based upon half the volume of the primary cell and the secondary cell volume from the invert of the discharge pipe to the maximum liquid level.

### ***Lagoon Liner***

Sewage lagoons are to be designed and constructed such that the interior surface of the proposed lagoon is underlain by soil with a thickness of at least one metre and having a hydraulic conductivity of  $1 \times 10^{-7}$  cm/sec or less. In the absence of soils with a hydraulic conductivity of  $1 \times 10^{-7}$  cm/sec or less, the interior surfaces of a lagoon could be lined with a synthetic liner.

### ***Effluent Quality Requirements***

Any new or expanding wastewater treatment lagoons are required to meet the Manitoba Water Quality Standards, Objectives and Guidelines - Tier 1 Water Quality Standards at a minimum, for discharged effluent. The effluent standards specific to the Woodlands lagoon would be:

- 200 fecal coliforms/100 ml or 200 E. coli/100 ml
- 25 mg/L BOD
- 25 mg/L TSS
- 1 mg/L Total Phosphorus or demonstrated nutrient reduction strategy.

#### **2.5.9.2 Nutrient Management Plan**

New nutrient reduction guidelines were released in the *Manitoba Water Quality Standards, Objectives, and Guidelines, November 28, 2011*. As outlined in Section 2.5.9.1 above, the regulations include province wide standards for phosphorus reduction. Under the new nutrient standards, a 1.0 mg/L phosphorus limit immediately applies for all new, expanding or modified wastewater treatment facilities. The exception being small wastewater treatment facilities that serve a population of less than 2,000 equivalent people, which have the option of implementing a nutrient reduction strategy instead of the 1.0 mg/L phosphorus limit. Nutrient reduction strategies include, but are not limited to, effluent irrigation, trickle discharge or constructed wetlands.

The *Lake Winnipeg Stewardship Board - Report to the Minister of Water Stewardship, December 2006* recommended several strategies for nutrient management with particular emphasis on phosphorus reduction. Based upon these strategies, the following options were considered for nutrient

management at the Woodlands wastewater treatment lagoon.

### ***Phosphorus Reduction by Filtration***

Sewage treatment plant technology, such as chemical addition and filtration systems could be utilized to reduce the phosphorus concentration in the lagoon. The effluent could be pumped through a filtration system prior to discharge. A chemical flocculent such as alum would have to be added to the wastewater prior to filtration. Backwash containing the phosphorus would be sent back to the primary cell where it settles out into sludge. The sludge will accumulate in the lagoon for approximately 20 - 25 years before requiring removal.

This level of treatment is costly as equipment and housing is required as well as annual operating costs and chemical costs. An electrical power source is also required, such as a hydro line to the lagoon. It is therefore not a feasible option for the Woodlands lagoon due to the higher capital cost and operating and maintenance costs.

### ***Phosphorus Reduction by Surface Chemical Treatment***

This option involves application of chemicals such as alum to wastewater in the secondary cell to reduce the level of phosphorus in the treated effluent, if prior to discharge the phosphorus concentration in the wastewater is found to be greater than 1.0 mg/L. The alum is broadcast onto the surface of the storage cells utilizing a gas driven pump and spray system from the top of the dike, or from a boat on the surface of the cells. The alum produces a chemical reaction with the phosphorus causing a pin floc. The pin floc of phosphorus and the turbidity settle to the bottom. The effluent can then be discharged from the secondary cell with a reduced level of phosphorus. This option requires higher operation and maintenance costs and was not the preferred option for the Woodlands lagoon.

### ***Constructed Wetlands***

Constructed wetlands are used to polish treated effluent from a lagoon, and have the potential to provide nutrient reduction. However, they can require large land areas for construction, have increased odour potential, can favour mosquito breeding (due to vegetation type, very shallow effluent and minimal wind action) and add cost to the project. In addition, the use of constructed/engineered wetlands requires further investigation regarding their effectiveness under climatic conditions in Manitoba. Due to the uncertain effectiveness of the system and the increased cost, the use of constructed/engineered wetlands for the Woodlands lagoon was not considered feasible.



### *Trickle Discharge*

Slower discharge is expected to increase opportunity for nutrients to be taken up by growing plants along the discharge route, which is a means of reducing phosphorus concentration in the treated effluent. The proposed drainage route is to the south, towards East Branch Sturgeon Creek (3<sup>rd</sup> Order Drain), via the lagoon perimeter ditch and the Municipal road ditch. East Sturgeon Creek eventually merges into Sturgeon Creek (4<sup>th</sup> Order Drain) which empties into the Assiniboine River. The total length of the drainage route is approximately 45 km prior to reaching the Assiniboine River. The maximum discharge volume from the lagoon will be approximately 30,407 m<sup>3</sup> (the total available volume in the storage cells). If the entire volume was discharged over a 6 week period, the discharge rate would be approximately 8.4 L/sec. Based on the trickle discharge rate from the lagoon and the length of drainage route, it is expected that natural uptake of nutrients by the plants and soils will occur.

### *Public Awareness*

In conjunction with nutrient reduction methods through treatment, preventative measures can also be taken to reduce nutrients in the wastewater influent. As the majority of the influent to the Woodlands lagoon would be residential in nature, the RM is encouraged to inform residents and schools in the community of nutrient reducing strategies, such as using non-phosphate based soap and cleaning products for domestic use. This would reduce the amount of phosphorus being released into the lagoon and reduce the requirements for treatment.

### *Recommended Option*

As the population being serviced by the Woodlands lagoon is less than 2,000 people, a nutrient reduction strategy would be recommended, as opposed to a phosphorus limit of 1.0 mg/L prior to discharge. Therefore, the recommendation for the Woodlands lagoon would be to utilize a trickle discharge from the storage cells (as described above). This option would require the least amount of operation and would be the most cost effective. In addition, the RM of Woodlands will be encouraged to notify residents in the community about the importance of nutrient source reduction in their homes.

## **2.5.10 Summarized Selected Design Criteria**

The following selected criteria would be used for design purposes:

- A total equivalent design population of 749 people being serviced from the piped collection system in the community in design year 26, for hydraulic loading capacity



- A total equivalent design population of 1,051 people being serviced from the piped collection system in the community in design year 44, for organic loading capacity
- A total equivalent design population of 400 people on septic tanks in the surrounding rural areas
- Primary cell with surface area of 17,867 m<sup>2</sup> at 0.75 m height from the floor, providing a daily organic treatment capacity of 100.1 kg BOD<sub>5</sub>/day
- A maximum of one truck load of septage per day
- A total hydraulic storage capacity in the storage cells above the invert elevation of 30,407 m<sup>3</sup>
- A total hydraulic storage capacity in the lagoon of 44,563 m<sup>3</sup>
- A storage period of 230 days
- A height of 2.5 m from the cell floor to the top of dike in the primary cell
- A height of 2.7 m from the cell floor to the top of dike in the storage cells
- The existing discharge pipe invert is 0.15 m above the cell floor elevation in storage cell #1
- The discharge pipe invert is proposed to be 0.3 m above the cell floor elevation in storage cell #2
- Discharge from the lagoon is expected to follow existing ditching route south towards East Branch Sturgeon Creek (3<sup>rd</sup> Order Drain)
- The horizontal liner will be constructed with a minimum 1.0 m thick in-situ clay liner
- A 3.0 m wide vertical cut-off wall constructed with re-worked clay soils will extend a minimum of 1.0 m into the horizontal clay liner and extend to the top of dike elevation
- The horizontal liner below the interior slopes of the primary cell will be constructed with re-worked clay soils
- A 4:1 slope will be used for the inner and outside dikes of the primary cell
- A truck turnaround and a spillway for trucked effluent would be provided in the new primary cell
- The existing forcemain piping will be extended to the new primary cell and the valve to the existing primary cell will be closed
- The existing spillway will be decommissioned by partially removing and restricting access

- A 1.5 m high barbed wire fence with lockable gate would be installed around the perimeter of the new primary cell
- Rip rap will be installed around the ends of the intercell and discharge piping
- A perimeter ditch will be constructed around the new primary cell
- Site markers, warning signs, and valve markers will be installed.

### **2.5.11 Lagoon Layout**

The lagoon would consist of a new primary cell constructed to the east and converting the existing primary cell into storage cell #2. The proposed lagoon layout is shown on Plan 2 in Appendix D.

### **2.5.12 Lagoon Construction Detail**

#### **2.5.12.1 General, Conceptual Liner Design and Construction Techniques**

Conceptual plans (Plans L1 to L8) for the lagoon expansion are provided in Appendix D.

The new primary cell would be excavated and the dikes constructed with excavated and compacted soil. The inner and outer dike slopes would be constructed at 4:1. In-situ clay soils will be used for the horizontal lagoon liner. Based on information obtained during the site investigation, the in-situ horizontal liner will not be located at the same elevation across the entire primary cell (see Plans L5 and L6 in Appendix D). Due to the natural slope of the in-situ clay material, this liner will be located approximately 0.3 m below the cell floor elevation at the location of TH2 (see Plans L5 and L6), and approximately 1.0 m below the cell floor elevation at the location of TH1 (see Plan L6). A more definitive location of the in-situ liner material throughout the expansion area will be determined during the construction works.

A 3.0 m wide vertical cut-off wall would be extended a minimum of 1.0 m below the horizontal liner, and constructed of re-worked clay soils from the site excavation. The horizontal lagoon liner beneath the inner slopes of the primary cell would consist of 1.0 m thick re-compacted and re-worked clay soils. While the in-situ horizontal liner is expected to meet the minimum permeability requirements, re-working this portion of the cell liner will ensure excavating the inner slopes of the lagoon cells, is not necessary if any unsuitable material is discovered during excavation and construction. The primary cell would have a proposed height of 2.5 m from the cell floor to the top of dike.

Due to the elevation of the suitable in-situ clay soil in the lagoon expansion area, the top of dikes of the primary cell will have an elevation approximately 1.0 m higher than the existing lagoon cells (proposed storage cells #1 and #2). Constructing the primary cell in this manner will allow for utilization of the suitable in-situ clay layer at the site and will not require an excessive amount of excavation to match the elevation of the existing cell floors. If the proposed primary cell floor were to be excavated to match the existing cell floor elevation, a portion of the in-situ clay liner material at the site would need to be removed and re-worked to form the horizontal liner, which would raise the project cost significantly.

It is proposed that the top of dikes of the existing lagoon cells (proposed storage cells) will be raised by 0.45 m, with compacted clay soils. The existing top of dikes would be excavated to a depth of approximately 0.6 m to expose the existing lagoon liner along the interior slopes (see Plan L4). This liner would be extended to the new top of dike elevation along the interior slopes, as the top of dike is reconstructed. Raising the dikes of the storage cells will allow for greater, cost effective hydraulic storage. Raising the dikes will also simplify maintenance and operation of the lagoon by the RM staff, due to the reduced elevation differences between the primary and storage cells. There will still be an elevation difference of 0.55 m between the primary and storage cells, with the primary cell being higher. The storage cells are proposed to have a total height of 2.7 m from the cell floor to the top of dike. Intercell and discharge pipes would be installed with rip rap around the pipe ends to prevent erosion. Existing valve boxes in the lagoon dikes would be raised to match the top of dike elevation.

The interior dike slopes would be constructed with compacted clay soils at the proposed lagoon upgrade site to ensure the liner is constructed and extended to the proper elevation. The outer dikes would be constructed with a compacted mixture of available soil on site. A perimeter ditch around the new primary cell would be constructed and connected to the existing perimeter ditch. The outer slope and perimeter drainage system would prevent surface drainage from entering into the lagoon and prevent ponding of surface water around the perimeter of the lagoon.

The specifications should state that the outer dikes, interior dikes from the high water mark to the top of dike, top of dikes and ditch embankments are to be seeded with a grass such as brome, to prevent soil erosion. The proposed barbed wire fence would be installed along the perimeter of the primary cell, outside of the lagoon dikes, and would connect to the existing lagoon barbed wire fence.

### 2.5.12.2 Construction Details

All topsoil would be removed to a minimum depth of 0.3 m from the cell construction area including the lagoon cell floor area. The cell floor surface of the newly constructed primary cell is to be scarified to a minimum depth of 0.15 m and compacted to a minimum Standard Proctor Density of 98%.

Construction of the lagoon cell liner (cell bottom and cut-off walls) should be in accordance with the following specifications:

1. The horizontal liner of the primary cell shall be constructed of in-situ clay soil material.
2. The cut-off wall of the primary cell and interior slope extensions of the storage cells shall be constructed of re-worked clay soil material.
3. The liner shall be a minimum of one metre in thickness.
4. The liner shall have a hydraulic conductivity of  $1 \times 10^{-7}$  cm/sec or less at all locations.

Embankment and liner material, should be compacted with a minimum of eight passes of a sheepsfoot roller on a 150 mm compacted lift. The cell bottom will be graded to a tolerance of  $\pm 50$  mm.

The lagoon construction specifications should indicate that the sheepsfoot roller shall have a minimum foot pressure of no less than 1,700 kPa (250 psi). The drum diameter of the sheepsfoot roller should not be less than 1,200 mm. Each roller should be equipped with cleaning fingers designed to prevent the accumulation of material between the tamping feet. The foot pressure would be calculated by taking the total mass of the roller and dividing it by the greater of: the area of the maximum number of tamping feet in one row parallel to the axis of the roller, or by 5 percent of the total foot area. The roller feet should be at least 200 mm long and should have a minimum area of at least 4,500 mm<sup>2</sup>.

A limited range of moisture content should be permitted. The material shall not be so wet nor so dry that compaction equipment cannot compact the fill into a homogeneous mass. Material too wet shall be dried or wasted as directed by the Engineer and material too dry shall be wetted as directed by the Engineer. All constructed earthen lagoon components shall be graded to a tolerance of  $\pm 50$  mm.

### 2.5.13 Decommissioning

The existing lagoon spillway would be decommissioned to prevent future truck haul dumping into the lagoon storage cells. Through raising the existing lagoon cell dikes, the bollards and a portion of the spillway on top of the dike will be removed and replaced

with compacted clay soil material. The spillway on the interior slope will be abandoned in place and posts with a chain and signage will be installed across the remaining spillway on the outside of the dike to prevent future truck hauled dumping. The forcemain to the lagoon would be diverted into the new primary cell and the existing forcemain inlet at the existing lagoon cell would be abandoned in place.

#### **2.5.14 Lagoon Maintenance**

Maintenance of the expanded lagoon will include:

- Maintaining the fencing, gate and lock
- Ensuring the gate is locked at all times and only the local septic haulers and RM Public Works department have access to the site
- Maintaining the intercell and discharge piping and valves
- Maintaining grass cover on dikes to a height of no more than 0.3 m in height
- Maintain a program to prevent and remove burrowing animals
- Maintain truck turnaround area
- Clearing of snow from the lagoon approach and truck turnaround.

## 3.0 POTENTIAL ENVIRONMENTAL IMPACTS

*The biophysical and socioeconomic environment as related to the development, and potential impacts of the development on the environment.*

### 3.1 Releases to Air, Water, Land

#### 3.1.1 Air

In general, nuisance odours occur in facultative lagoons that are improperly sized and organically overloaded. Odours are also generated under anaerobic conditions. During the summer the lagoon would be aerobic at the surface, facultative at the centre and anaerobic at the bottom. Minimal to no treatment would occur in the winter due to the ice cover on the surface; the treatment process would predominantly be anaerobic during winter. Therefore, the lagoon may generate some odours for a short time each spring during the thawing or turn-over period when water temperature inversion causes turbulence in the lagoon cells and gases produced from the anaerobic treatment process are brought to the surface. Prevailing winds in the area can carry odours if the area is exposed and wind breaks are not utilized around the lagoon cells.

There is also a potential for greenhouse gas emissions during construction works from heavy equipment and transport vehicles. Impacts from dust generation are not expected as the construction area will meet the minimal setback distances from residences.

Environmental management practices to mitigate the above potential impacts to the air are provided in Section 4.1 of this report.

#### 3.1.2 Water

Pollutants that may be released into surface and ground water during the operation of the lagoon include coliforms, organic wastes, suspended solids, and other materials that are typically disposed of into the sewer system in the Community of Woodlands. Pollutants in the wastewater produced by the community are expected to be residential in nature.

Pollutants that have a potential to be released into the surface or ground water during the lagoon upgrade construction activities, include petroleum hydrocarbons (PHCs) from heavy equipment and sediments from soil erosion.

##### *Surface Water*

Surface water may be impacted if the wastewater is not sufficiently treated and subsequently discharged from the lagoon. Effluent discharged from the lagoon would eventually reach Sturgeon Creek and the Assiniboine River. There is also potential to impact surface water via sedimentation from soil erosion in the discharge stream during the construction works.

The discharge from the lagoon should not cause or contribute to flooding in or along the drainage route. The lagoon would not be discharged during flood conditions. There is no potential to impact the navigation of surface waters as a result of the lagoon project, as the proposed drainage route is not in the immediate vicinity of a navigable body of water.

### *Groundwater*

There is a potential for groundwater impacts if wastewater leaks/seeps through the lagoon liner or forcemain pipe and into the groundwater below. There is also a potential for groundwater impacts from equipment leaks or fuel spills during construction.

Environmental management practices to mitigate the above potential impacts to water are provided in Section 4.2 of this report.

### **3.1.3 Land**

The land would be significantly altered by construction of the lagoon dikes and perimeter ditching. Fencing would be installed around the perimeter of the new lagoon cell.

Pollutants that may be released to the land are predominantly petroleum hydrocarbons (PHCs), which could be released during construction activities. Equipment leaks, or re-fuelling incidences, could result in an impact to the land as a result of construction activities.

Disturbed areas can be impacted through soil erosion if not covered or re-vegetated. Environmental management practices to mitigate the above potential impacts to the land are provided in Section 4.3 of this report.

## **3.2 Wildlife**

The proposed lagoon site is located in the “Lake Manitoba Plan” Ecoregion of Canada. Characteristic wildlife includes white-tailed deer, coyote, rabbit and ground squirrel. Bird species include waterfowl.

The Manitoba Conservation Data Centre was contacted regarding the proposed lagoon project and indicated that there were no occurrences of rare species at the proposed lagoon expansion site in their database. Refer to the Manitoba Conservation Wildlife and Ecosystem Branch, November 29, 2012 email correspondence, attached in Appendix B.

Impacts to wildlife and wildlife habitat are not expected, as the lagoon expansion is to be located on agricultural land which is regularly disturbed by farming activities.

### **3.3 Fisheries**

Impacts to fish along the discharge route are unlikely as the lagoon effluent would be discharged after fish spawning has normally occurred and only when the treated effluent meets current Manitoba Conservation water quality guidelines for surface discharge.

### **3.4 Forestry**

There are no potential impacts to forestry as the area of lagoon expansion has been previously cleared due to agriculture and no forestry areas would be impacted.

### **3.5 Vegetation**

Characteristic vegetation in the Lake Manitoba Plain ecoregion is classified as being a transitional area between areas of boreal forest to the north and aspen parkland to the southwest. It is a mix of trembling aspen/oak groves and rough fescue grasslands.

Manitoba Conservation Wildlife and Ecosystem Protection Branch was contacted regarding occurrences of rare or endangered vegetative species in their database at the proposed lagoon expansion site. There were no occurrences of rare species identified at the development site. Refer to Manitoba Conservation Wildlife and Ecosystem Protection Branch email correspondence dated November 29, 2012, attached in Appendix B.

No significant impacts to vegetation in the development area are anticipated, as the site is currently agricultural land which is disturbed regularly through farming activities.

### **3.6 Noise Impacts**

There is a potential for noise impacts in the immediate area due to the heavy equipment utilized during construction. Mitigation measures described in Section 4.4 below will be in place during the construction works. Other than maintenance vehicles (for lagoon effluent sampling or mowing grass) or septic hauling trucks, the operation of the lagoon itself, will not have a potential for noise impacts.

### **3.7 Health and Safety**

There is a potential for impacts to the health and safety of workers and the public during the construction works. Mitigation measures described in Section 4.5 below will be in place during the construction works.

### **3.8 Heritage Resources**

The Manitoba Historic Resources Branch was contacted regarding the proposed site. The Historic Resources Branch indicated that the potential to impact significant heritage resources is low and that they have no concerns with the project. Refer to the Manitoba Historic Resources Branch December 11, 2012 memorandum, in Appendix B.



The RM of Woodlands has also reviewed the site location and has no concerns for the proposed development site in regards to heritage or historic resources. While impacts to historic or heritage resources are not expected at the site, there is a potential for an unexpected discovery when excavating an area which has not previously been excavated. Mitigation measures described in Section 4.6 below will be in place during the construction works.

### **3.9 Socio-Economic Implications**

The lagoon expansion is not expected to have adverse socio-economic impacts. In fact, construction related economic activity is likely to have a positive economic impact on the community. In addition the community would have increased wastewater capacity upon completion of the project, which will encourage future growth in the community.

### **3.10 Aesthetics**

The lagoon expansion is not expected to have adverse impacts on the general aesthetics of the area, as the lagoon construction would occur adjacent to the existing lagoon cells.

## **4.0 MANAGEMENT PRACTICE**

*Proposed environmental management practices to be employed to prevent or mitigate adverse implications from the impacts identified above.*

### **4.1 Mitigation of Impacts to Air**

To reduce the potential for odour nuisance in the community, the primary cell will be sized for the projected year 20 organic loadings, from the surrounding population. This also takes into consideration the maximum allowable organic loading rate of 56 kg BOD<sub>5</sub>/ha into the lagoon primary cell, which affects the odours generated from a wastewater treatment lagoon peak organic loading, which occurs during septic truck dumping. Therefore, nuisance odours as a result of organic over-loading are not expected.

Although the lagoon would likely generate some odours for a short time each spring, during the thawing or turn-over period, prevailing (i.e. northwesterly) winds should not cause odours to drift toward the community, which is northwest of the lagoon. Furthermore, the proposed lagoon upgrade would be located a minimum of 300 metres from the nearest resident and 460 metres from the Community of Woodlands, as required by Manitoba Conservation.

Emissions from construction equipment and transport vehicles will be controlled through regular maintenance, and will meet all provincial and local standards. Dust suppression methods (i.e. water spraying) will be utilized at the construction site if dry conditions create excessive dust through construction activities and transport, which becomes a nuisance to nearby residents. Due to the setback distance, it is unlikely that dust will have any impact on the community or to nearby residents.

### **4.2 Mitigation of Impacts to Water**

#### **4.2.1 Surface Water**

Impacts to surface water from discharge of lagoon effluent are not expected, as the lagoon effluent would not be discharged unless Tier I Manitoba Water Quality Standards, Objectives and Guidelines are met, as follows:

1. The organic content of the effluent, as indicated by the five day biochemical oxygen demand would not be greater than 25 mg/L
2. The total suspended solids would not be greater than 25 mg/L
3. The fecal coliform content of the effluent, as indicated by the MPN index would not be greater than 200 per 100 ml of sample, or *Escherichia coli* content not greater than 200 per 100 ml of sample.
4. The total phosphorus content of the effluent would not exceed 1 mg/L or have a demonstrated nutrient reduction strategy.

Impacts to surface water due to discharge of the lagoon are not expected, as treatment will occur in the lagoon cells and measures such as a trickle discharge can be utilized to further reduce nutrient loading to surface waters.

Erosion from excess material stockpiles would be prevented by the use of silt fencing at drainage locations and by either covering the soil stockpiles or seeding with grass. Clean rock (free of fine materials) from an appropriate land-based source would be utilized to eliminate occurrence of erosion at the lagoon discharge outlet. Silt fencing would be installed in the perimeter ditching during construction and should remain in place until grass growth is established. Perimeter ditch slopes would be seeded with grass to control erosion and sediment entry into the discharge route. Disturbance of the soils adjacent to the perimeter ditches and discharge route would be minimized during construction.

To minimize impacts from construction equipment on surface waters, the construction specifications should outline to the contractor the requirements for handling and storage of fuels and hazardous materials during construction, as per Federal and Provincial regulations. The specification should state wording similar to the following:

- Diesel or gasoline should be stored in double walled tanks or have containment dikes around fuel containers for volumes greater than 68.2 L (15 gallons) or in compliance with provincial regulations
- Clean up material should be available at the site, consisting of a minimum of 25 kg of suitable commercial sorbent, 30 m<sup>2</sup> of 6 mil PVC, and an empty fuel barrel for spill collection and disposal
- Fuel storage and hazardous material areas established for project construction should be located a minimum of 100 m from a waterbody, and comply with provincial regulations
- Waste hazardous materials from construction activities and equipment must be properly collected and disposed of in compliance with provincial regulations
- In the event of spills or leaks of fuels and hazardous materials, the contractor or operator should notify the project engineer and Provincial Authorities.

Hazardous material handling and storage are to follow all Provincial and Federal regulations including WHMIS and spill containment requirements.

The specifications should state that when working near water with construction equipment:

- Construction equipment is to be properly maintained to prevent leaks and spills of fuels, lubricants, hydraulic fluids or coolants
- There can be no re-fueling or servicing of construction equipment within 100 m of a water body.

There would be no impacts to navigation as a result of the lagoon project, as the discharge route is not a navigable body of water. If flooding occurs along the drainage route, the RM must not discharge the lagoon. The discharge should not cause or contribute to flooding in or along the drainage route.

#### **4.2.2 Groundwater**

Seepage of effluent from the lagoon is unlikely to affect groundwater as the new lagoon primary cell and storage cell extensions would utilize a clay liner, having a hydraulic conductivity of  $1 \times 10^{-7}$  cm/sec or less, as required by Manitoba Conservation guidelines.

The re-directed portion of forcemain will be pressure tested prior to commissioning and maintained by the RM of Woodlands during operation to prevent underground wastewater leaks.

Mitigation of potential impacts to groundwater during the lagoon construction activities from fuel handling, equipment leaks or fuel spills, would follow the same procedures as described in Section 4.2.1 above.

### **4.3 Mitigation of Impacts to Land**

As the lagoon would utilize a clay liner, seepage to the surrounding land is expected to be negligible. To minimize the potential for the release of Petroleum Hydrocarbon (PHC) pollutants into the soil, the mitigation measures described in Section 4.2.1 above outlining fuel-handling procedures should be followed.

To minimize the potential for slope erosion, the outside slopes of the dikes would be constructed with a 4:1 slope and the dike tops, outside slopes and soil stockpiles would be seeded with grass. The discharge outlet location would be covered with rip-rap to eliminate soil erosion into the ditch during discharge events.

### **4.4 Mitigation of Noise Impacts**

To minimize the potential for noise impacts, construction equipment and transport vehicles should have mufflers working properly, and construction activities should be limited to daylight hours only.

### **4.5 Mitigation of Impacts to Health and Safety**

To minimize impacts to health and safety of workers and the public, the construction specifications should state that the Contractor have a safety program in place, in accordance with all Federal and Provincial Health and Safety Regulations. During construction, site access will be limited to the construction crew only. Personal protective equipment will be worn in accordance with the Contractor's safety program.

## **4.6 Mitigation of Impacts to Heritage Resources**

If any significant historic or heritage resources are discovered in the course of excavation or construction, the specifications should identify that works are to temporarily cease and an investigation of the site is to be conducted by the RM, Manitoba Historic Resources Branch and any other authority as may be required.

## **5.0 RESIDUAL AND CUMULATIVE EFFECTS**

*Residual environmental effects remaining after the application of mitigation measures, to the extent possible expressed in quantitative terms relative to baseline conditions*

No negative residual effects are anticipated through the construction and operation of the upgraded wastewater treatment lagoon, due to the mitigation measures described above. Positive residual effects are expected from the properly sized wastewater treatment system, which will allow for expansion of the service area in the future.

## **6.0 MONITORING AND FOLLOW-UP**

*Proposed follow-up activities that will be required at any stage of development (eg. Monitoring, inspection, surveillance, audit, etc.)*

Monitoring of the lagoon operation is to be conducted by a trained lagoon operator, who is to ensure the lagoon is operated under the requirements of the environmental licence. The operator is to ensure liquid levels in the lagoon cells are maintained within the required limits, conduct sampling of lagoon effluent prior to discharge, and is to ensure water quality guidelines as described in the environmental licence are met. The construction contractor is to ensure that grass growth occurs on slopes and disturbed areas, after the construction activities are completed.

## **7.0 FUNDING AND APPROVALS**

*Name and address of any Government Agency or program (federal, provincial or otherwise) from which a grant or loan of capital funds have been requested (where applicable). Other federal, provincial or municipal approvals, licences, permits, authorizations, etc. known to be required for the proposed development, and the status of the project's application or approval.*

Partial funding for this project is being sought through Provincial and Federal sources. No additional approvals, licences or permits are required for the lagoon construction and operation.



## **8.0 PUBLIC CONSULTATION**

*Results of any public consultations undertaken or to be undertaken in conjunction with project planning.*

Public consultation by the RM of Woodlands has not been conducted to date for the residents of Woodlands. Public consultation is being planned by the RM, during future phases of the project. Public comments will be received by Manitoba Conservation through the public registry during the Environmental Act Proposal review period.

## **9.0 CONCLUSION**

Based on the design of the project and the implementation of the mitigation measures identified in Section 4.0 above, no significant negative environmental impacts are anticipated.

The proponent would like to complete the requirements of the Environment Act Proposal as soon as possible so that the lagoon construction can begin by the time specified in Section 2.5.1 above.

J. R. Cousin Consultants Ltd. requests that a draft copy of the licence be forwarded for review prior to the issue of the final licence.

# **APPENDICES**

## **APPENDIX A**

Land Titles Transactions (Instrument Number 2744813)

Land Title (Number 1989566/1)

Crown Lands & Property Agency – Lands Branch, December 4, 2012 Email Correspondence

## **APPENDIX B**

Table 1: Community of Woodlands Population, Hydraulic and Organic Loading Projections

Manitoba Conservation and Water Stewardship Fisheries Branch, November 23, 2012

Email Correspondence

Manitoba Conservation Wildlife and Ecosystem Protection Branch, November 29, 2012

Email Correspondence

Manitoba Historic Resources Branch, December 11, 2012 Memorandum

## **APPENDIX C**

Test Hole Logs

National Testing Laboratories Soils Analysis Results

Driller's Well Logs

## **APPENDIX D**

Title Page

Plan L1: Proposed Lagoon Expansion Location Plan with Setbacks

Plan L2: Proposed Lagoon Expansion Layout with Test Hole Locations

Plan L3: Lagoon Discharge Route

Plan L4: Perimeter Dike and Transition Area

Plan L5: Lagoon Section West to East

Plan L6: Lagoon Section North to South

Plan L7: Valve, Valve Marker, Sign, Rip Rap, Ditch and Silt Fence Details

Plan L8: Spillway, Truck Turnaround, Gate and Lock Details

## **Appendix A**

Land Titles Transactions (Instrument Number 2744813)

Land Title (Number 1989566/1)

Crown Lands & Property Agency – Lands Branch, December 4, 2012  
Email Correspondence

Land Titles Transactions (Instrument Number 2744813)

Land Title (Number 1989566/1)

New CT#: Winnipeg - 1888254

Status: Active

Instrument Type TRANSFER OF LAND  
Vendor HM THE QUEEN (MANITOBA)  
Consolidated? No

Sale Date Jul 17, 2002  
Consideration \$1  
Sworn Value \$10,500

RURAL MUNICIPALITY OF WOODLANDS

IS REGISTERED OWNER SUBJECT TO SUCH ENTRIES RECORDED HEREON IN THE FOLLOWING DESCRIBED LAND:

WORKS PLAN 29104 WLTO  
IN SE 1/4 23-14-2 WPM

Address:  
RURAL MUNICIPALITY OF  
WOODLANDS  
BOX 10  
WOODLANDS MB  
R0C 3H0

From CT: Winnipeg - 1278204 ALL

#206  
Roll 69850  
SEPT 17/02  
CD.

Roll entries for this instrument: 206 - R.M. OF WOODLANDS Roll: 69850 R

Assessment Roll ✓  
Reindex N/A ✓  
To → Bev/Chris Wells ✓  
Computer ✓  
Print ✓  
Type ✓

DATE: 2012/10/11  
TIME: 07:13

**MANITOBA**  
STATUS OF TITLE

TITLE NO: 1989566/1  
PAGE: 1

STATUS OF TITLE..... ACCEPTED  
ORIGINATING OFFICE... WINNIPEG  
REGISTERING OFFICE... WINNIPEG  
REGISTRATION DATE.... 2003/12/23  
COMPLETION DATE..... 2004/01/08

PRODUCED FOR.. RM OF WOODLANDS  
ADDRESS.....

CLIENT FILE... NA  
PRODUCED BY... L.DERRY

**LEGAL DESCRIPTION:**

JOHN RUSSELL LANGRELL AND DOROTHY JANICE LANGRELL  
BOTH OF WOODLANDS, MANITOBA

ARE REGISTERED OWNERS AS JOINT TENANTS, SUBJECT TO SUCH ENTRIES  
RECORDED HEREBY, IN THE FOLLOWING DESCRIBED LAND:

FIRSTLY: SE 1/4 23-14-2 WPM,  
EXC, WORKS, PLAN 29104 WLTO.

SECONDLY: ALL THAT PORTION OF NW 1/4 14-14-2 WPM,  
WHICH LIES TO THE NE OF THE NORTHEASTERN LIMIT OF RIGHT OF WAY OF RLY,  
PLAN 1038 WLTO.

THIRDLY: ALL THAT PORTION OF SW 1/4 14-14-2 WPM,  
WHICH LIES TO NE OF THE NORTHEASTERN LIMIT OF RIGHT OF WAY OF RLY,  
PLAN 1038 WLTO.

**ACTIVE TITLE CHARGE(S):**

235791/1 ACCEPTED CAVEAT REQ'D: 1975/08/05  
FROM/BY: MANITOBA TELEPHONE SYSTEM  
TO:  
CONSIDERATION: NOTES: AFF: 2NDLY AND 3RDLY

2091887/1 ACCEPTED CAVEAT REQ'D: 1996/12/10  
DESCRIPTION: EASEMENT  
FROM/BY: MTS NETCOM INC.  
TO:  
CONSIDERATION: NOTES: AFF: WTN LTS R/W PL 34205

**ADDRESS(ES) FOR SERVICE:**

EFFECT	NAME AND ADDRESS	POSTAL CODE
ACTIVE	JOHN LANGRELL GENERAL DELIVERY WOODLANDS, MB.	ROC 3H0

CERTIFIED TRUE EXTRACT PRODUCED FROM THE LAND TITLES DATA  
STORAGE SYSTEM ON 2012/10/11 OF TITLE NUMBER 1989566/1

DATE: 2012/10/11  
TIME: 07:13

# MANITOBA

## STATUS OF TITLE

TITLE NO: 1989566/1

PAGE: 2

STATUS OF TITLE..... ACCEPTED  
ORIGINATING OFFICE... WINNIPEG  
REGISTERING OFFICE... WINNIPEG  
REGISTRATION DATE.... 2003/12/23  
COMPLETION DATE..... 2004/01/08

PRODUCED FOR.. RM OF WOODLANDS  
ADDRESS.....

CLIENT FILE... NA  
PRODUCED BY... L.DERRY

### ADDRESS(ES) FOR SERVICE:

EFFECT	NAME AND ADDRESS	POSTAL CODE
ACTIVE	DOROTHY LANGRELL GENERAL DELIVERY WOODLANDS, MB.	ROC 3H0

### ORIGINATING INSTRUMENT(S):

REGISTRATION NUMBER	TYPE	REG. DATE	CONSIDERATION	SWORN VALUE
2934259/1	T	2003/12/23	\$1.00	\$232,960.00
PRESENTED BY: GRANTHAM LAW OFFICE				
FROM: RUSSELL JAMES LANGRELL AND JEAN MABEL LANGRELL				
TO: JOHN RUSSELL LANGRELL AND DOROTHY JANICE LANGRELL				

### FROM TITLE NUMBER(S):

1278208/1 ALL

### LAND INDEX:

LOT	QUARTER SECTION	SECTION	TOWNSHIP	RANGE
NOTE:	NW	14	14	2W
	PART NE OF PLAN 1038			
NOTE:	SW	14	14	2W
	PART NE OF PLAN 1038			
NOTE:	SE	23	14	2W
	EXC PLAN 29104			

ACCEPTED THIS 23RD DAY OF DECEMBER, 2003  
BY G.BILODEAU FOR THE DISTRICT REGISTRAR OF  
THE LAND TITLES DISTRICT OF WINNIPEG.

CERTIFIED TRUE EXTRACT PRODUCED FROM THE LAND TITLES DATA  
STORAGE SYSTEM ON 2012/10/11 OF TITLE NUMBER 1989566/1.

\*\*\*\*\* END OF STATUS OF TITLE 1989566/1 \*\*\*\*\*



Crown Lands & Property Agency – Lands Branch,  
November 29, 2012 Email Correspondence

## Oswald Wohlgemut

---

**From:** Little, Karen (CLPA) [Karen.Little@gov.mb.ca]  
**Sent:** Tuesday, December 04, 2012 12:52 PM  
**To:** 'Oswald Wohlgemut'  
**Subject:** RE: Woodlands Lagoon - Mineral Rights - SE 23-14-2 WPM

Good afternoon Oswald, according to our records this date, SE 23-14-2 WPM was originally granted by the Federal Government in 1881 along with the mines & minerals and sand & gravel. The Crown owns no interests.

Based on Certificate of Titles 1888254 and 1989566/1, the mines & minerals and sand & gravel are private owned with these surface titles.

Sincerely,

**Karen Little**

Supervisor of Crown Lands Registry

Crown Lands and Property Agency

308 - 25 Tupper Street North

Portage la Prairie MB R1N 3K1

P (204) 239-3805 F (204) 239-3560

Toll Free 1-866-210-9589

[karen.little@gov.mb.ca](mailto:karen.little@gov.mb.ca)



*An Agency of MB Infrastructure and Transportation*

---

**From:** Oswald Wohlgemut [<mailto:owohlgemut@jrcc.ca>]  
**Sent:** November-26-12 2:46 PM  
**To:** Little, Karen (CLPA)  
**Subject:** Woodlands Lagoon - Mineral Rights

Hello Karen,

J.R. Cousin Consultants Ltd. (JRCC) is preparing an Environment Act Proposal on behalf of the R.M. of Woodlands for a proposed lagoon expansion project. The proposed site for construction is located on Plan 29104 WLTO in SE ¼ 23-14-2 WPM and in the remainder of SE ¼ 23-14-2 WPM. The site is located on land owned by the RM, as well as land which is privately owned. The land at the expansion site is currently being used for agriculture.

I have attached a copy of the land titles transaction and land title for the site. Would you please provide information regarding the ownership of the Mineral Rights.

Thank you,

Oswald Wohlgemut, M.Sc.  
Environmental Scientist

J.R. Cousin Consultants Ltd.  
Phone: (204) 489-0474  
Fax: (204) 489-0487  
[www.jrcc.ca](http://www.jrcc.ca)

## **Appendix B**

Table 1: Community of Woodlands Population, Hydraulic and Organic Loading Projections

Manitoba Conservation and Water Stewardship Fisheries Branch, November 23, 2012  
Email Correspondence

Manitoba Conservation Wildlife and Ecosystem Protection Branch, November 29, 2012  
Email Correspondence

Manitoba Historic Resources Branch, December 11, 2012 Memorandum

Table 1: Community of Woodlands Population, Hydraulic and Organic Loading Projections

**TABLE 1: COMMUNITY OF WOODLANDS - POPULATION, HYDRAULIC AND ORGANIC LOADING PROJECTIONS**

Col 1	Col 2	Col 3	Col 4	Col 5	Col 6	Col 7	Col 8	Col 9	Col 10	Col 11	Col 12	Col 13	Col 14
Calendar Year	Design Year	Population				Hydraulic Loading				Organic Loading			
		Woodlands Population	Mobile Home Population	School Equivalent Population	Rural Population	Daily per Capita Wastewater Production*	Yearly per Capita Wastewater Production	Daily Wastewater Production**	Wastewater Volume For 230 Days	Daily per Capita B.O.D.	B.O.D. PEAK DAILY LOADING	Daily B.O.D. Production	Primary Cell Area Req'd at 0.75 m
		Growth per year	Growth per year	Growth per year	Growth per year	Woodlands, Mobile Home and School	Rural Areas	All Sources (Col 3 + Col 4 + Col 5) x Col 7)+(Col 6 x Col 8/135 days)/1000	All Sources ( Col 9 x 230)	Woodlands, Mobile Home and School	Septage Hauling from Rural Residents	All Sources ((Col 3 + Col 4 + Col 5) x Col 11)+(Col 12)	(@56kgBOD/ha/day)
		2.1%	0.5%	0.0%	0.0%	(litres)	(litres)	(cu. m.)	(cu. m.)	(kg)	kg	(kg)	(sq. m.)
2012	0	396	35	35	400	258	200	121	27,807	0.076	20.1	55.5	9,918
2013	1	404	35	35	400	258	200	123	28,292	0.076	20.1	56.2	10,029
2014	2	413	35	35	400	258	200	125	28,797	0.076	20.1	56.8	10,144
2015	3	421	35	35	400	258	200	127	29,313	0.076	20.1	57.5	10,262
2016	4	430	36	35	400	258	200	130	29,840	0.076	20.1	58.1	10,383
2017	5	439	36	35	400	258	200	132	30,377	0.076	20.1	58.8	10,506
2018	6	448	36	35	400	258	200	134	30,925	0.076	20.1	59.5	10,631
2019	7	457	36	35	400	258	200	137	31,484	0.076	20.1	60.2	10,759
2020	8	466	36	35	400	258	200	139	32,055	0.076	20.1	61.0	10,889
2021	9	476	36	35	400	258	200	142	32,637	0.076	20.1	61.7	11,022
2022	10	486	37	35	400	258	200	144	33,231	0.076	20.1	62.5	11,158
2023	11	496	37	35	400	258	200	147	33,837	0.076	20.1	63.3	11,297
2024	12	506	37	35	400	258	200	150	34,456	0.076	20.1	64.1	11,438
2025	13	517	37	35	400	258	200	153	35,087	0.076	20.1	64.9	11,583
2026	14	527	37	35	400	258	200	155	35,731	0.076	20.1	65.7	11,730
2027	15	538	38	35	400	258	200	158	36,388	0.076	20.1	66.5	11,880
2028	16	549	38	35	400	258	200	161	37,058	0.076	20.1	67.4	12,034
2029	17	561	38	35	400	258	200	164	37,742	0.076	20.1	68.3	12,190
2030	18	572	38	35	400	258	200	167	38,441	0.076	20.1	69.2	12,350
2031	19	584	38	35	400	258	200	170	39,153	0.076	20.1	70.1	12,513
<b>2032</b>	<b>20</b>	<b>596</b>	<b>38</b>	<b>35</b>	<b>400</b>	<b>258</b>	<b>200</b>	<b>173</b>	<b>39,880</b>	<b>0.076</b>	<b>20.1</b>	<b>71.0</b>	<b>12,679</b>
<b>2038</b>	<b>26***</b>	<b>674</b>	<b>40</b>	<b>35</b>	<b>400</b>	<b>258</b>	<b>200</b>	<b>194</b>	<b>44,563</b>	<b>0.076</b>	<b>20.1</b>	<b>77.0</b>	<b>13,750</b>
<b>2056</b>	<b>44****</b>	<b>973</b>	<b>43</b>	<b>35</b>	<b>400</b>					0.076	20.1	<b>100.1</b>	<b>17,867*****</b>

\* Includes infiltration

\*\*Assumes rural residents can only contribute wastewater to the lagoon over 135 days in the summer

\*\*\*Design year based on proposed hydraulic capacity after raising dikes

\*\*\*\*Design year based on proposed organic capacity

\*\*\*\*\*Organic capacity based on increasing the size of the primary cell to accommodate additional hydraulic storage

Manitoba Conservation and Water Stewardship Fisheries Branch,  
November 23, 2012 Email Correspondence

## Oswald Wohlgemut

---

**From:** Janusz, Lauren R (MWS) [Lauren.Janusz@gov.mb.ca]  
**Sent:** Friday, November 23, 2012 11:31 AM  
**To:** 'Oswald Wohlgemut'  
**Cc:** Biggin, Wade (MWS)  
**Subject:** Fish Species - Sturgeon Creek

Hi Oswald,

Sturgeon Creek supports a number of large (various life stages) and small bodied fish species, at least seasonally providing spawning, rearing and foraging habitat. Sturgeon Creek does support a recreational fishery. According to the Fisheries Inventory and Habitat Classification System the following species have been collected in creek:

White sucker, yellow perch, black bullheads, black crappie, blacknose dace, blacknose shiner, bluntnose minnow, brook stickleback, brown bullhead, carp, central mudminnow, channel catfish, common shiner, creek chub, emerald shiner, fathead minnow, flathead chub, freshwater drum, golden redhorse, golden shiner, goldeye, Johnny darter, log perch, longnose dace, mooneye, northern pike, quillback, river shiner, rock bass, sand shiner, sauger, shorthead redhorse, silver chub, silver lamprey, silver redhorse, slimy sculpin, spottail shiner, stonecat, tadpole madtom, trout perch and walleye.

Regarding spawning habitat in Sturgeon Creek, in 1993 a colleague and I sampled the reach below Portage Avenue and found walleye to be utilizing the lower reach of Sturgeon Creek for spawning purposes. Sucker and pike eggs were also evident along this reach. There has also been extensive enhancement work since that evaluation that has provided for fish passage past Old Grant's Mill and included the construction of a number of riffle structures utilized to improve stream habitat and stabilize the creek bed and bank reducing erosion.

For **East Branch Sturgeon Creek**, the FIHCS notes fathead minnows and brook stickleback were collected.

Please note that information from FIHCS comes from a number of sources and as such we cannot guarantee the species listed are 100% accurate. Also the species when entered are not linked to a location so the list includes everything reported to be found in the creeks.

The following is more site specific information regarding fish captures on Sturgeon Creek and an unnamed tributary just north of the perimeter. These are often just captures at one time and season but does demonstrate the extent to which some species are found quite far upstream in Sturgeon Creek. This information was from a couple of Live Fish Handling Permits issued for Sturgeon Creek, I have included the date and what was captured below the relevant figures. There was also a report on Sturgeon Creek done by NS for the Centre Port Canada Way Project, however they focussed on habitat classifications of various reaches and then just utilized existing fish species information from the FIHCS which included information from a 2006 City of Winnipeg Report. From the City of Winnipeg Report the most upstream reach they sampled was at Optimist Park, north of Saskatchewan Ave. I've included the information at the very bottom of the email.



Figure 1. Location of construction site and salvage fishery (conducted June 11 and 14) associated with the unnamed tributary of Sturgeon Creek.



June 11, 2010 at location noted in Figure above:

Northern pike – 13 (FL 72-355 mm)

Central Mudminnow – 6

Brook Stickleback – 5

June 14, 2010 at location noted in Figure above:

Northern Pike – 9 (FL 77-104 mm)

Central Mudminnow – 1

Brook Stickleback - 4



Figure 1. Location of the Sturgeon Creek diversion at structure 3, relative to Provincial Trunk Highway #101.

Nov 30 2010 at location noted in Figure above:

Northern Pike – 12 (FL 160-350 mm)

White Sucker –3 (FL 205-310 mm)

Common Carp – 2 (FL 180-200 mm)

Brook Stickleback – 55

Fathead Minnow – 1055

April 26, 2011 at same location:

Central Mudminnow – 29

Fathead Minnow - >800

White Sucker – 1

Brook Stickleback – 6

## Sturgeon Creek

Site ID: 12

**Location** Optimist Park, north of Saskatchewan Ave.

**Description** An upstream portion of the creek that can become quite narrow and shallow but holds water year round. The banks are no-mow.

---

**Date** 25/04/2005 **Trap Type** Gill Net **Time** 15:00 **Time Spent Fishing** 3:20 **Sampling ID** 74

**Sampling Details** 3" mesh, rain, 3 C, 1m depth, net set downstream of flooded riffles - 5 C

**Common Name Species Name Number Age Class Fish Details**

White Sucker *Catostomus commersoni* 1 Adult male, 40 cm, released

---

**Date** 13/05/2005 **Trap Type** Gill Net **Time** 16:00 **Time Spent Fishing** 3:35 **Sampling ID** 166

**Sampling Details** 3" mesh

**Common Name Species Name Number Age Class Fish Details**

None *None* 0

---

**Date** 17/05/2005 **Trap Type** Minnow Trap **Time** 13:30 **Time Spent Fishing** 97:05 **Sampling ID** 167

**Sampling Details** Both traps removed, Sunny, 18 C, 1 m depth, caught a crayfish

**Common Name Species Name Number Age Class Fish Details**

Brook Stickleback *Culaea inconstans* 2 Adult released

---

**Date** 15/08/2005 **Trap Type** Seine Net **Time** 14:45 **Time Spent Fishing** **Sampling ID** 1124

**Sampling Details** Mostly cloudy, 22 C, Unidentified (sucker) - 4 caught 1 specimen taken, Unidentified (fathead) - 94 caught, specimen taken.

**Common Name Species Name Number Age Class Fish Details**

Brook Stickleback *Culaea inconstans* 81 Adult released

Common Carp *Cyprinus carpio* 2 Juvenile released

White Sucker *Catostomus commersoni* 1 Juvenile 16 cm, released

---

**Date** 22/04/2006 **Trap Type** Gill Net **Time** 14:00 **Time Spent Fishing** 5:30 **Sampling ID** 1675

**Sampling Details** Water Temp 13 C, Sunny, Depth 1 m +

**Common Name Species Name Number Age Class Fish Details**

Northern Pike *Esox lucius* 1 Adult 51 cm, male, released

Northern Pike *Esox lucius* 1 Adult 52 cm, male, released

White Sucker *Catostomus commersoni* 1 Adult 33 cm Fork, 34 cm total, released

White Sucker *Catostomus commersoni* 1 Adult 35 cm Fork, 36 cm total, released

White Sucker *Catostomus commersoni* 1 Adult 31 cm Fork, 33 cm total, released

Any questions on the material provided, please feel free to email or call. Have a great day.

Laureen Janusz

Fisheries Science and Fish Culture Section

Fisheries Branch

Conservation and Water Stewardship  
Phone: 204 945-7789  
Cell: 204 793-1154  
Email: [Laureen.Janusz@gov.mb.ca](mailto:Laureen.Janusz@gov.mb.ca)

---

**From:** Oswald Wohlgemut [mailto:[owohlgemut@jrcc.ca](mailto:owohlgemut@jrcc.ca)]  
**Sent:** November-22-12 4:46 PM  
**To:** Janusz, Laureen R (MWS)  
**Subject:** Fish Species - Sturgeon Creek

Hello Laureen,

J.R. Cousin Consultants Ltd. (JRCC) is preparing an Environment Act Proposal on behalf of the RM of Woodlands for the Woodlands Lagoon expansion project. The expansion will be constructed adjacent to the existing lagoon cells and the existing discharge route will be utilized. The discharge ditch intersects with East Branch Sturgeon Creek at 14-14-2 WPM. East Branch Sturgeon Creek flows south to Sturgeon Creek and eventually into the Assiniboine River.

If you have the data, please provide a list of fish species known to exist in East Branch Sturgeon Creek and Sturgeon Creek, along with any fish spawning information you may have near the project area, as we would like to include this information in the Environment Act Proposal.

Please do not hesitate to contact us if you have any questions.

Thank you,

Oswald Wohlgemut, M.Sc.  
Environmental Scientist

J.R. Cousin Consultants Ltd.  
Phone: (204) 489-0474  
Fax: (204) 489-0487  
[www.jrcc.ca](http://www.jrcc.ca)

\*\*\*

The information contained in this email and any attachments is privileged, confidential and subject to copyright. It is intended solely for the use of the person(s) to whom it is addressed. If you receive this email in error, please notify the sender by return email and permanently delete it from your system. Note: We have taken precautions against viruses, but take no responsibility for loss or damage caused by any virus present.

**Manitoba Conservation Wildlife and Ecosystem Protection Branch**  
**November 29, 2012 Email Correspondence**

## Oswald Wohlgemut

---

**From:** Friesen, Chris (CON) [Chris.Friesen@gov.mb.ca]  
**Sent:** Thursday, November 29, 2012 10:46 AM  
**To:** 'Oswald Wohlgemut'  
**Subject:** RE: Species at Risk - Woodlands

Oswald

Thank you for your information request. I completed a search of the Manitoba Conservation Data Centre's rare species database and found no occurrences at this time for your area of interest.

The information provided in this letter is based on existing data known to the Manitoba Conservation Data Centre at the time of the request. These data are dependent on the research and observations of CDC staff and others who have shared their data, and reflect our current state of knowledge. **An absence of data in any particular geographic area does not necessarily mean that species or ecological communities of concern are not present;** in many areas, comprehensive surveys have never been completed. Therefore, this information should be regarded neither as a final statement on the occurrence of any species of concern, nor as a substitute for on-site surveys for species as part of environmental assessments.

Because the Manitoba CDC's Biotics database is continually updated and because information requests are evaluated by type of action, any given response is only appropriate for its respective request. Please contact the Manitoba CDC for an update on this natural heritage information if more than six months pass before it is utilized.

Third party requests for products wholly or partially derived from Biotics must be approved by the Manitoba CDC before information is released. Once approved, the primary user will identify the Manitoba CDC as data contributors on any map or publication using Biotics data, as follows as: Data developed by the Manitoba Conservation Data Centre; Wildlife and Ecosystem Protection Branch, Manitoba Conservation.

**This letter is for information purposes only - it does not constitute consent or approval of the proposed project or activity, nor does it negate the need for any permits or approvals required by the Province of Manitoba.**

We would be interested in receiving a copy of the results of any field surveys that you may undertake, to update our database with the most current knowledge of the area.

If you have any questions or require further information please contact me directly at (204) 945- 7747.

Chris Friesen  
Biodiversity Information Manager  
Manitoba Conservation Data Centre  
204-945-7747  
[chris.friesen@gov.mb.ca](mailto:chris.friesen@gov.mb.ca)  
<http://www.gov.mb.ca/conservation/cdc/>

---

**From:** Oswald Wohlgemut [<mailto:owohlgemut@jrcc.ca>]  
**Sent:** November-22-12 4:36 PM  
**To:** Friesen, Chris (CON)  
**Subject:** Species at Risk - Woodlands

Hello Chris,

J.R. Cousin Consultants is conducting an Environment Act Proposal on behalf of the RM of Woodlands, Manitoba for the expansion of the existing lagoon. The construction works will occur at SE 23-14-2 WPM. The area proposed for expansion is regularly farmed agricultural land directly to the east of the existing lagoon cells. Works will include dike construction, perimeter ditch construction and fence installation.

Please provide information on any at risk wildlife and plant species that are known to exist in the location outlined above, as well as any registered habitat areas, as we would like to include that information in the Environmental Assessment.

Please let us know if you have any questions.

Thank you,

Oswald Wohlgemut, M.Sc.  
Environmental Scientist

J.R. Cousin Consultants Ltd.  
Phone: (204) 489-0474  
Fax: (204) 489-0487  
[www.jrcc.ca](http://www.jrcc.ca)

\*\*\*

The information contained in this email and any attachments is privileged, confidential and subject to copyright. It is intended solely for the use of the person(s) to whom it is addressed. If you receive this email in error, please notify the sender by return email and permanently delete it from your system. Note: We have taken precautions against viruses, but take no responsibility for loss or damage caused by any virus present.

Manitoba Historic Resources Branch, December 11, 2012 Memorandum



DATE: December 11, 2012

TO: Oswald Wohlgemut  
JR Cousin Consultants Ltd.  
91 A Scurfield Boulevard  
Winnipeg MB

FROM: Gordon Hill  
Impact Assessment  
Archaeologist  
Historic Resources  
Branch  
Main Floor 213 Notre  
Dame Avenue  
Winnipeg MB  
R3B 1N3  
PHONE NO: (204) 945-7730

SUBJECT: HERITAGE RESOURCES

YOUR FILE:

HRB FILE: AAS-12-5270

LAGOON EXPANSION  
SE 23-14-2 WPM  
RM WOODLANDS

In response to your memo regarding the above-noted project, I have examined Branch records for areas of potential concern. The potential to impact significant heritage resources is low, and, therefore, the Historic Resources Branch has no concerns with the project.

If at any time however, significant heritage resources are recorded in association with these lands during development, the Historic Resources Branch may require that an acceptable heritage resource management strategy be implemented by the developer to mitigate the affects of development on the heritage resources.

If you have any questions or require further comments, please contact me at 945-7730.

C. Gordon Hill

## **Appendix C**

Test Hole Logs

















National Testing Laboratories Soils Analysis Results

Driller's Well Logs

## Test Hole Logs

**J. R. Cousin Consultants Ltd.**  
TEST HOLE LOGS

**SYMBOL INDEX**

	GW. : Well graded gravels and gravel sand mixtures, little or no fines
	GP. : Poorly graded gravels, gravel - sand mixtures, little or no fines
	GM. : Silty gravels, gravel-sand-silt mixtures
	GC. : Clayey gravels, gravel-sand-clay mixtures
	SW. : Well graded sands, gravelly sands, little or no fines
	SP. : Poorly graded sands, or gravelly sands, little or no fines
	SM. : Silty sands, sand-silt mixtures
	SC. : Clayey sands, sand-clay mixtures
	ML. : Inorganic silts and very fine sands, rock flour, silty or clayey fine sands, or clayey silts with slight plasticity
	CL. : Inorganic clays of low plasticity, gravelly clays, sandy or silty clays, lean clays
	OL. : Organic silts and organic silty clays of low plasticity
	CI. : Inorganic clays of medium or intermediate plasticity
	MH. : Inorganic silts, fine sandy or silty soils
	CH. : Inorganic clays of high plasticity, fat clays
	OH. : Organic clays of medium to high plasticity, organic silts
	Pt. : Peat, humus, swamp soils with high organic contents
	TOPSOIL

The soil logs are based upon objective data available to us at the time of forming our opinions. The soil logs indicate site specific soil characteristics and must not be generalized over larger areas due to the limited number of test holes as compared to that of an unlimited number of test holes. Every effort is made to evaluate the information by methods generally recognized. The soil logs represent our opinions. J.R. Cousin Consultants Ltd. cannot be responsible for actual site conditions proved to be materially at variance from our analysis or from the data generalization over untested areas.

# J. R. Cousin Consultants Ltd.

## TEST HOLE LOG SHEET

LOCATION : SE 23-14-2 WPM

DATE : June 14, 2012

PROJECT : R.M. of Woodlands Lagoon Feasibility Study

ELEVATION : 251.729m

TEST HOLE # 1

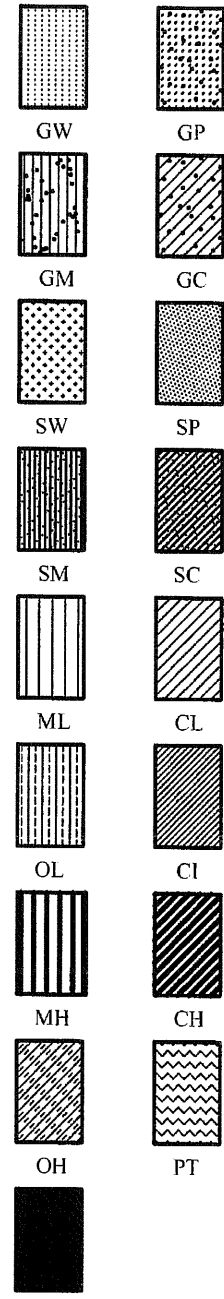
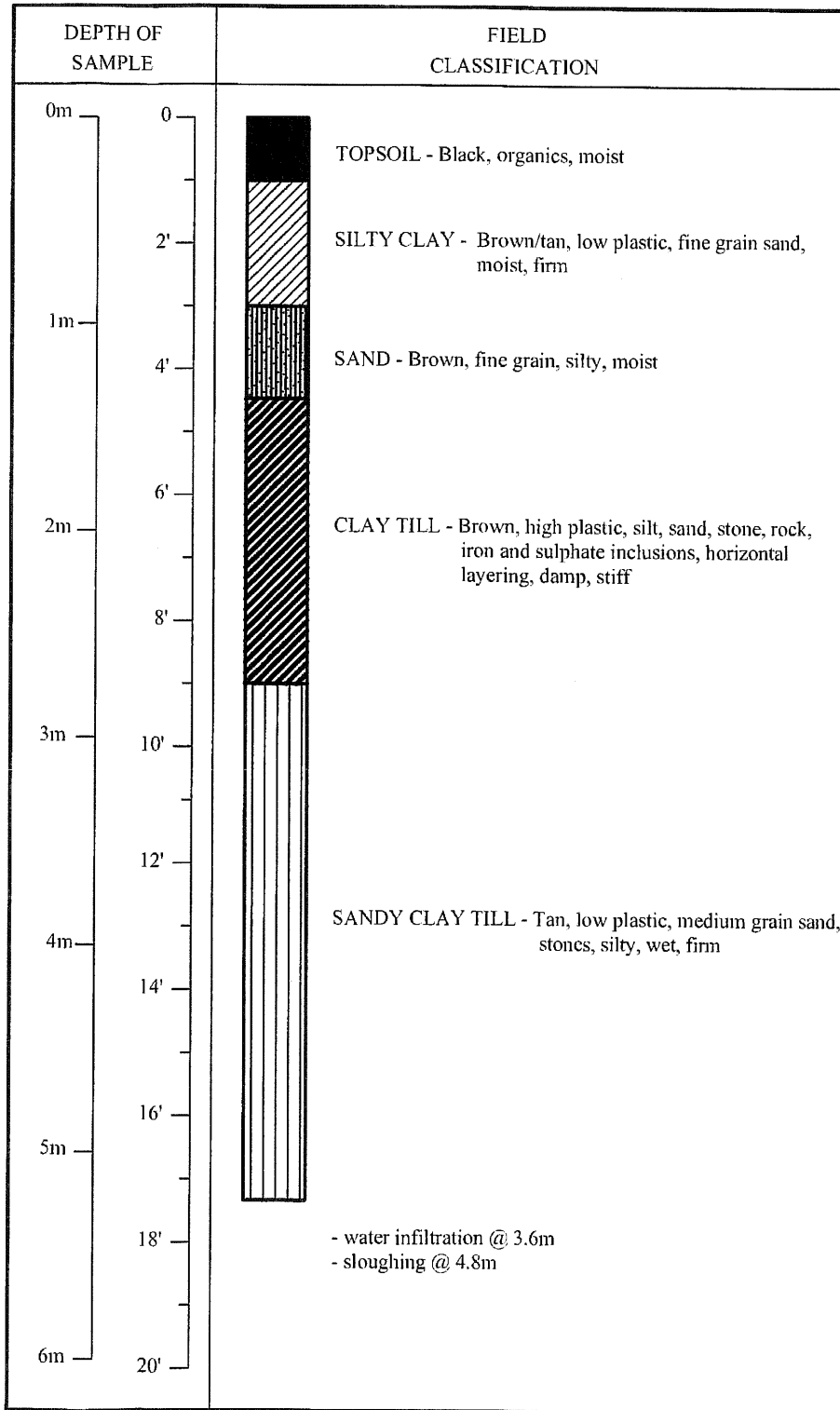

The soil logs are based upon objective data available to us at the time of forming our opinions. The soil logs indicate site specific soil characteristics and must not be generalized over larger areas due to the limited number of test holes as compared to that of an unlimited number of test holes. Every effort is made to evaluate the information by methods generally recognized. The soil represent our opinions. J.R. Cousin Consultants Ltd. cannot be responsible for actual site conditions proved to be materially at variance from our analysis or from the data generalization over untested areas.

# J. R. Cousin Consultants Ltd.

## TEST HOLE LOG SHEET

LOCATION : SE 23-14-2 WPM

DATE : June 14, 2012

PROJECT : R.M. of Woodlands Lagoon Feasibility Study

ELEVATION : 252.087m

TEST HOLE # 2

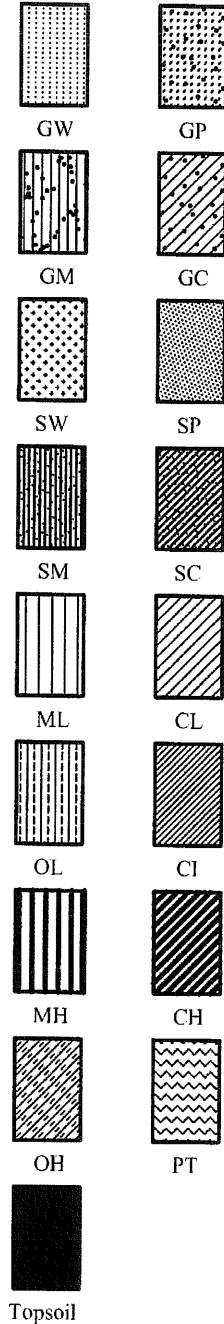
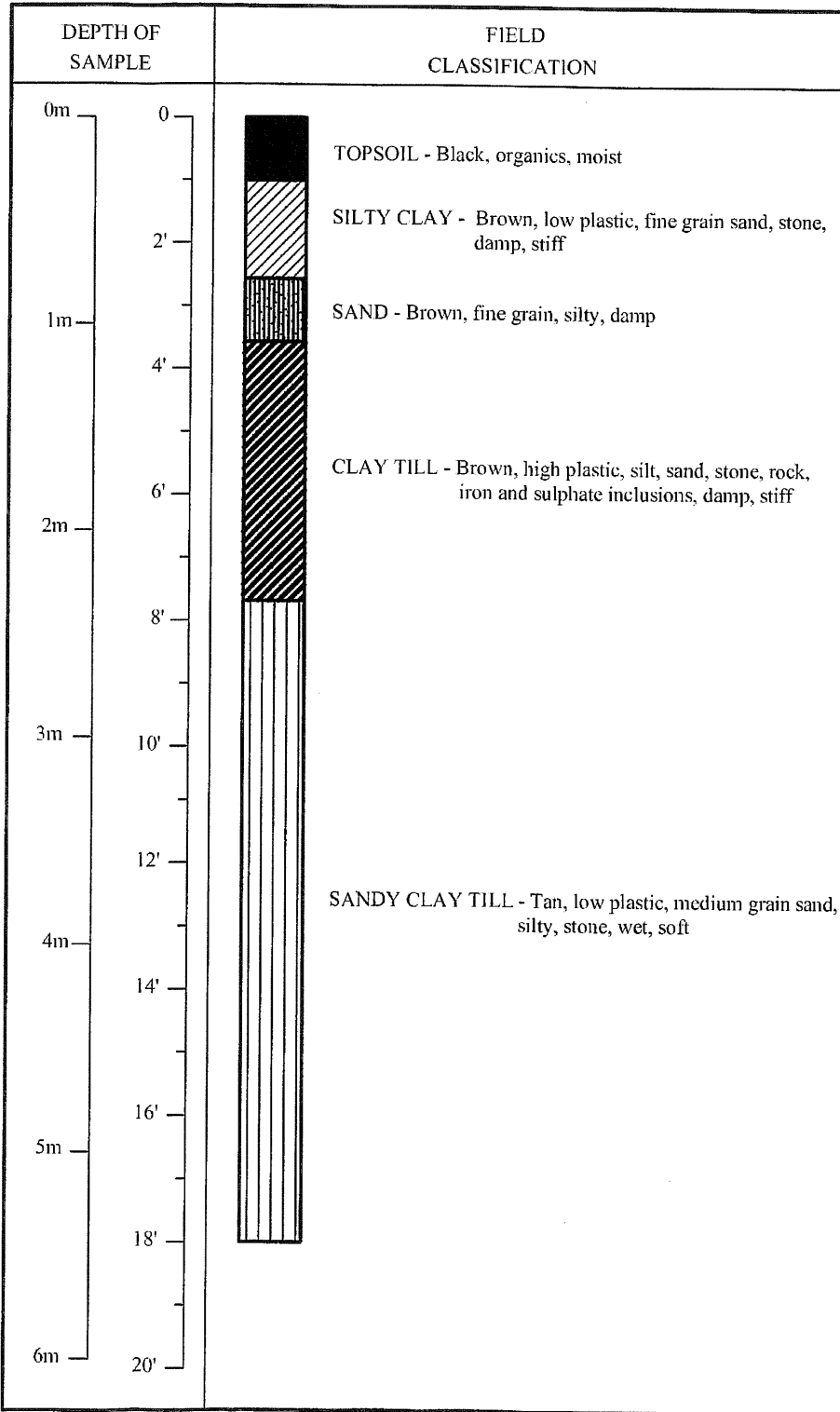

The soil logs are based upon objective data available to us at the time of forming our opinions. The soil logs indicate site specific soil characteristics and must not be generalized over larger areas due to the limited number of test holes as compared to that of an unlimited number of test holes. Every effort is made to evaluate the information by methods generally recognized. The soil represent our opinions. J.R. Cousin Consultants Ltd. cannot be responsible for actual site conditions proved to be materially at variance from our analysis or from the data generalization over untested areas.

# J. R. Cousin Consultants Ltd.

## TEST HOLE LOG SHEET

LOCATION : SE 23-14-2 WPM

DATE : June 14, 2012

PROJECT : R.M. of Woodlands Lagoon Feasibility Study

ELEVATION : 252.299m

TEST HOLE # 3

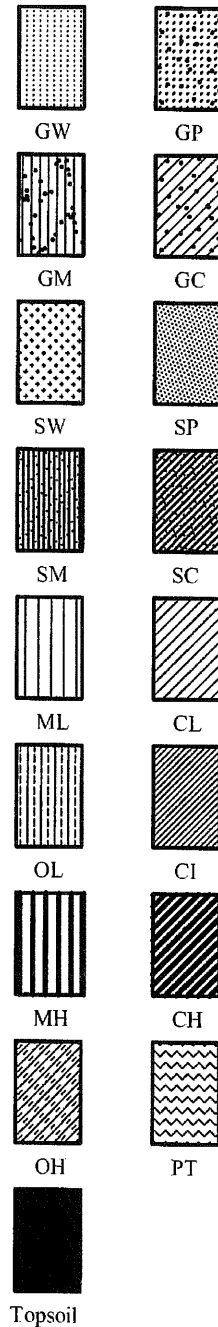
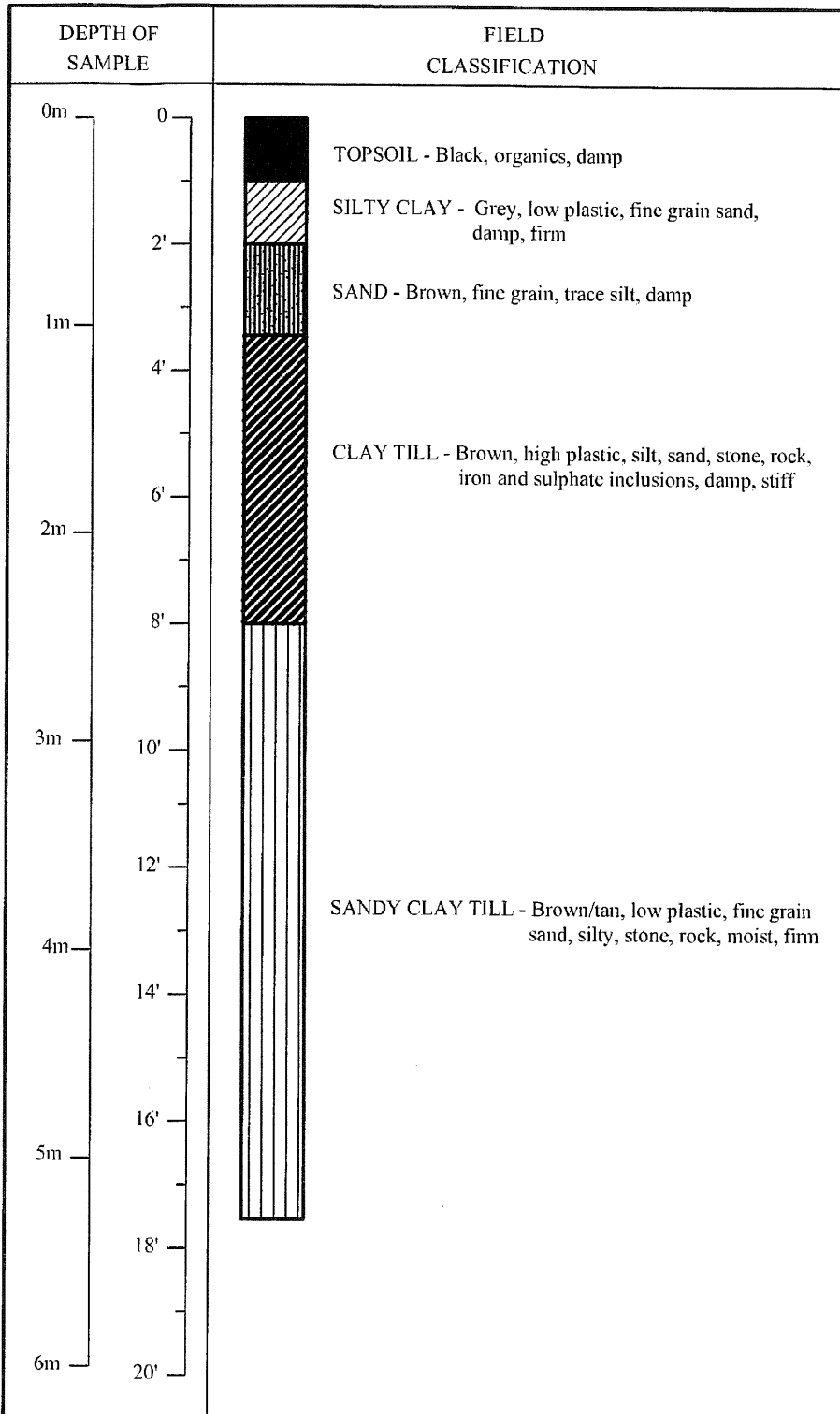

The soil logs are based upon objective data available to us at the time of forming our opinions. The soil logs indicate site specific soil characteristics and must not be generalized over larger areas due to the limited number of test holes as compared to that of a unlimited number of test holes. Every effort is made to evaluate the information by methods generally recognized. The soil represent our opinions. J.R. Cousin Consultants Ltd. cannot be responsible for actual site conditions proved to be materially at variance from our analysis or from the data generalization over untested areas.

# J. R. Cousin Consultants Ltd.

## TEST HOLE LOG SHEET

LOCATION : SE 23-14-2 WPM

DATE : June 14, 2012

PROJECT : R.M. of Woodlands Lagoon Feasibility Study

ELEVATION : 251.827m

TEST HOLE # 4

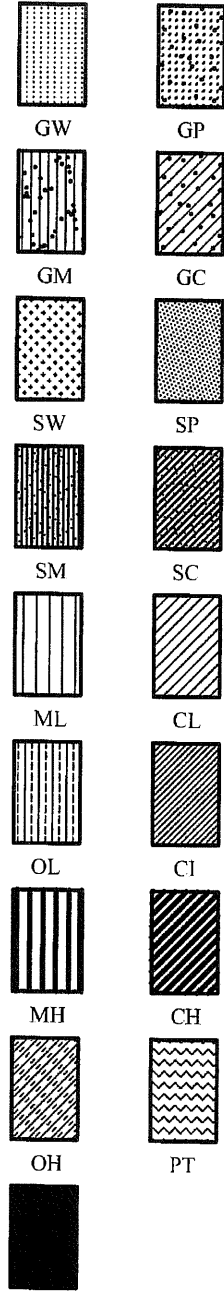
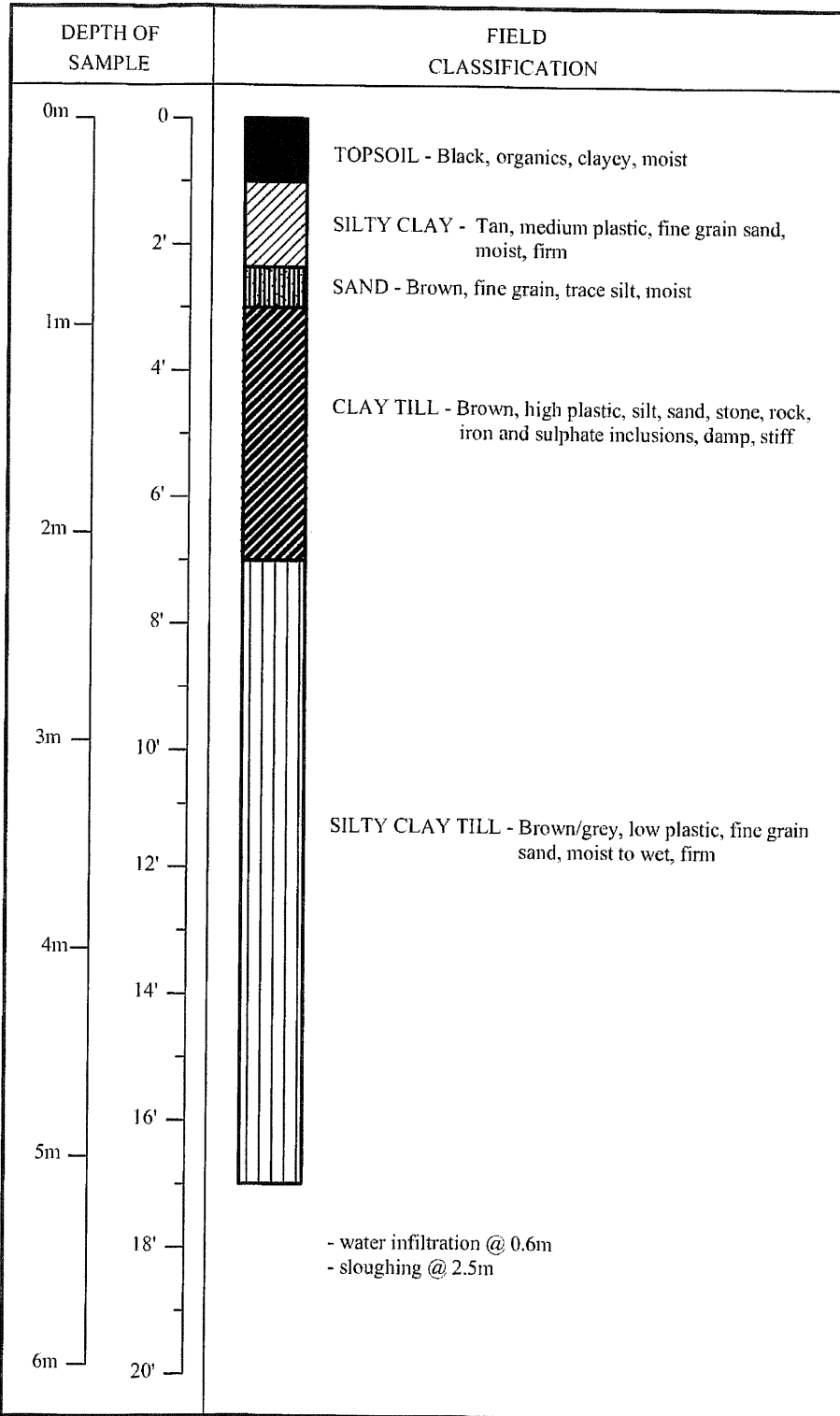

The soil logs are based upon objective data available to us at the time of forming our opinions. The soil logs indicate site specific soil characteristics and must not be generalized over larger areas due to the limited number of test holes as compared to that of an unlimited number of test bores. Every effort is made to evaluate the information by methods generally recognized. The soil represent our opinions. J.R. Cousin Consultants Ltd. cannot be responsible for actual site conditions proved to be materially at variance from our analysis or from the data generalization over untested areas.



# J. R. Cousin Consultants Ltd.

## TEST HOLE LOG SHEET

LOCATION : SE 23-14-2 WPM

DATE : June 14, 2012

ELEVATION : 252.763m

PROJECT : R.M. of Woodlands Lagoon Feasibility Study

TEST HOLE # 5

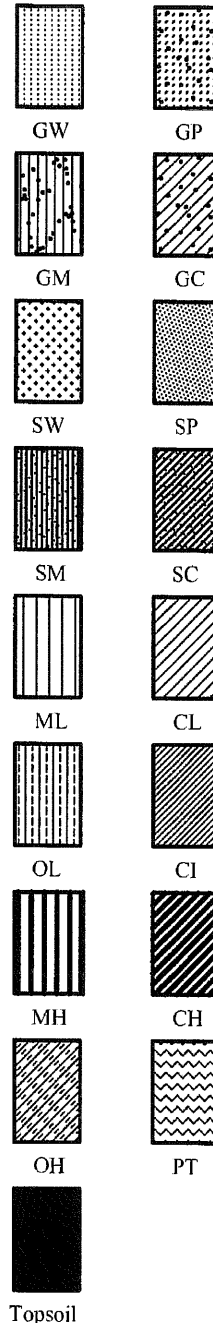
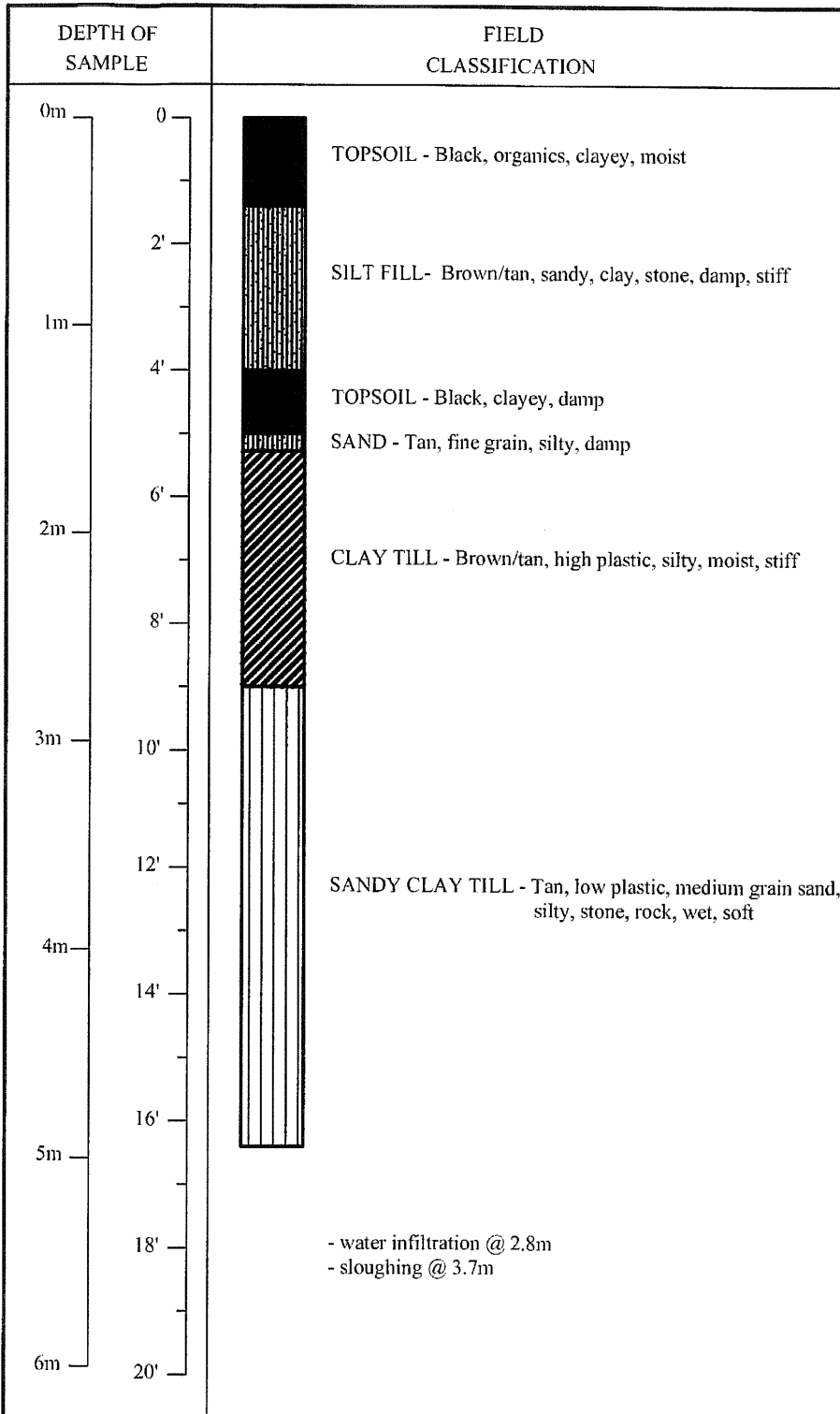

The soil logs are based upon objective data available to us at the time of forming our opinions. The soil logs indicate site specific soil characteristics and must not be generalized over larger areas due to the limited number of test holes as compared to that of a unlimited number of test holes. Every effort is made to evaluate the information by methods generally recognized. The soil represent our opinions. J.R. Cousin Consultants Ltd. cannot be responsible for actual site conditions proved to be materially at variance from our analysis or from the data generalization over untested areas.

# J. R. Cousin Consultants Ltd.

## TEST HOLE LOG SHEET

LOCATION : SE 23-14-2 WPM

DATE : June 14, 2012

PROJECT : R.M. of Woodlands Lagoon Feasibility Study

ELEVATION : 252.668m

TEST HOLE # 6

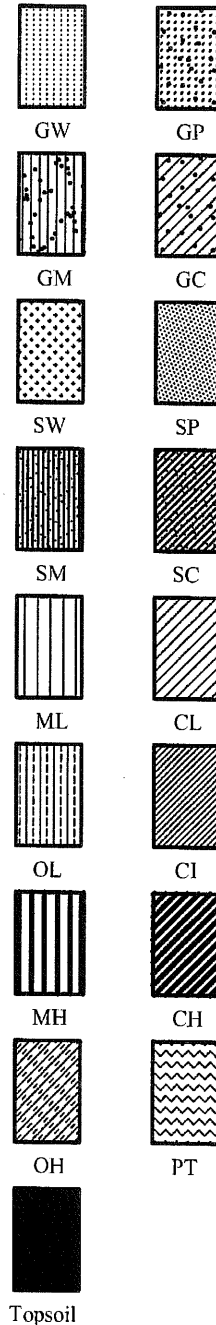
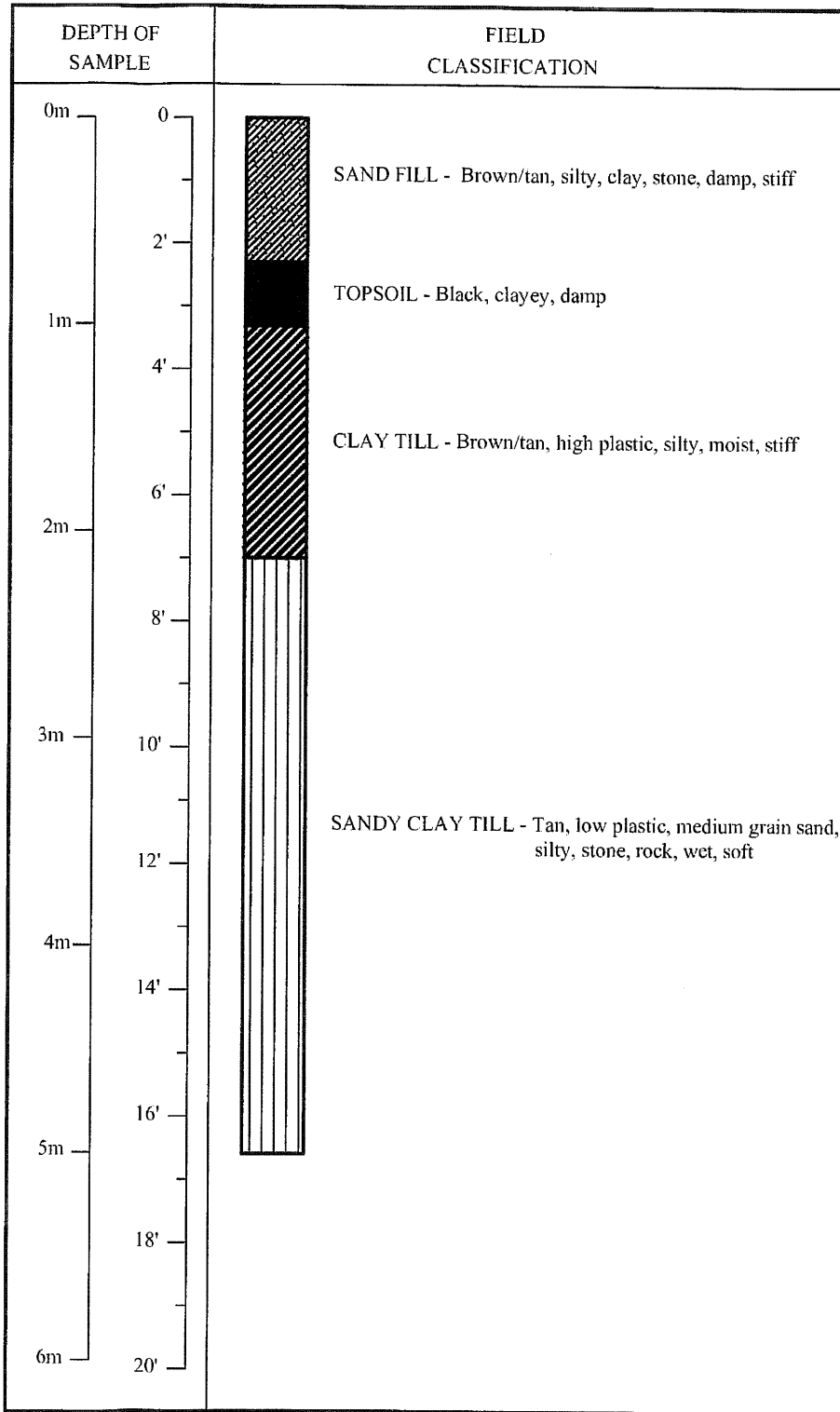

The soil logs are based upon objective data available to us at the time of forming our opinions. The soil logs indicate site specific soil characteristics and must not be generalized over larger areas due to the limited number of test holes as compared to that of a unlimited number of test holes. Every effort is made to evaluate the information by methods generally recognized. The soil represent our opinions. J.R. Cousin Consultants Ltd. cannot be responsible for actual site conditions proved to be materially at variance from our analysis or from the data generalization over untested areas.

## National Testing Laboratories Soils Analysis Results



J.R. Cousin Consultants Ltd.  
91 A Scurfield Blvd.  
Winnipeg, Manitoba  
R3Y 1G4

Attention: Oswald Wohlgemut

July 23, 2012

Project: Woodlands Lagoon  
Expansion

Soil samples were submitted to our laboratory on June 28, 2012. The following tests were conducted on selected soil samples:

- water content (ASTM D2216)
- particle size analysis (ASTM D422)
- liquid limit, plastic limit, and plasticity index (ASTM D4318)
- soil classification (ASTM D2487)
- hydraulic conductivity (ASTM D5084)
- visual classification

The test results for the soil samples are summarized in the following tables and in the attached particle size analysis and hydraulic conductivity reports.

An assessment of the bagged soil samples was conducted to determine whether the soil represented by the bagged samples could be used in-situ as a lagoon liner and would obtain a hydraulic conductivity of less than  $1.0 \times 10^{-7}$  cm/sec without being reworked, and when re-moulded and re-compacted.

Based upon previous testing conducted in our laboratory, homogeneous soil samples with a plasticity index greater than 25 and a clay content greater than 50% will typically have a hydraulic conductivity of  $1.0 \times 10^{-7}$  cm/sec or less. The bagged samples identified as TH3 1.0-2.5 m was considered suitable for use as a lagoon liner. Sample TH3 2.5-5.4 m had a plasticity index of 17 and a clay content of 35.2%, which does not fall within this range. Hydraulic conductivity testing of a representative Shelby tube sample of this material is recommended to determine its suitability for use as a lagoon liner. Our comments regarding the potential use of the material as a lagoon liner are based upon the soil being homogeneous with no preferential flow paths and being properly placed and compacted to maximum density near its optimum moisture content. It should be noted that estimating the hydraulic conductivity of a soil based upon classification test results (plasticity index and particle size analysis) alone might be misleading if the soil contains layers of sand, silt, or organic material.

The hydraulic conductivity results for Shelby tube sample TH3 1.0-2.5 m is less than the specified maximum hydraulic conductivity value of  $1.0 \times 10^{-7}$  cm/s for lagoon liners.

We appreciate the opportunity to assist you in this project. Please call if you have any questions regarding this report.

Farouk Fourar-Laidi, B.Sc., EIT  
Geotechnical Engineering

**TABLE 1  
SUMMARY OF WATER CONTENT, PARTICLE SIZE, ATTERBERG LIMITS, SOIL CLASSIFICATION TEST DATA  
WOODLANDS LAGOON EXPANSION**

Testhole	Depth (m)	Visual Classification	Water Content (%)	Gravel (%) 75 to 4.75 mm	Sand (%)			Silt (%) <0.075 to 0.005 mm	Clay (%) <0.005 mm	Liquid Limit	Plastic Limit	Plasticity Index	Soil Classification ASTM D2487	Potential use as a lagoon liner when re-moulded and re-compacted	Potential use as a lagoon liner without being reworked
					Coarse <4.75 to 2.0 mm	Medium <2.0 to 0.425 mm	Fine <0.425 to 0.075 mm								
TH3	1.0 – 2.5	brown, stiff, moist, high plasticity clay with some silt, trace fine sand and trace fine to coarse gravel	24.9	4.0	0.7	2.2	5.9	16.7	70.5	59	17	42	CH (Fat clay)	Yes	Yes
TH3	2.5 – 5.4	tan, firm, moist, low plasticity silty clay, sandy with trace fine to coarse gravel	14.3	5.6	2.8	8.2	14.5	33.7	35.2	28	11	17	CL (Sandy lean clay)	No	No

**Notes:**

1. Atterberg limits conducted in accordance with ASTM D4318 Method B (one-point liquid limit).
2. The soil samples were air-dried during sample preparation for Atterberg limits and particle size analysis.

**TABLE 2  
SUMMARY OF HYDRAULIC CONDUCTIVITY TEST DATA  
WOODLANDS LAGOON EXPANSION**

Testhole	Depth (m)	Hydraulic Conductivity, "k <sub>20</sub> "
TH3	1.0 – 2.5	9.2 x 10 <sup>-9</sup> cm/s



**THE  
NATIONAL  
TESTING  
LABORATORIES  
LIMITED**  
Established in 1923

# PARTICLE SIZE ANALYSIS ASTM D422

J.R. Cousin Consultants Ltd.  
91 A Scurfield Blvd  
Winnipeg, Manitoba  
R3Y 1G4

PROJECT: Woodlands Lagoon Expansion

Attention: Oswald Wohlgemut

PROJECT NO.: JRC-1209

SAMPLED BY: Client  
SAMPLE ID: TH3 1.0-2.5 m

DATE RECEIVED: June 27, 2012  
TESTED BY: Sothea Bun

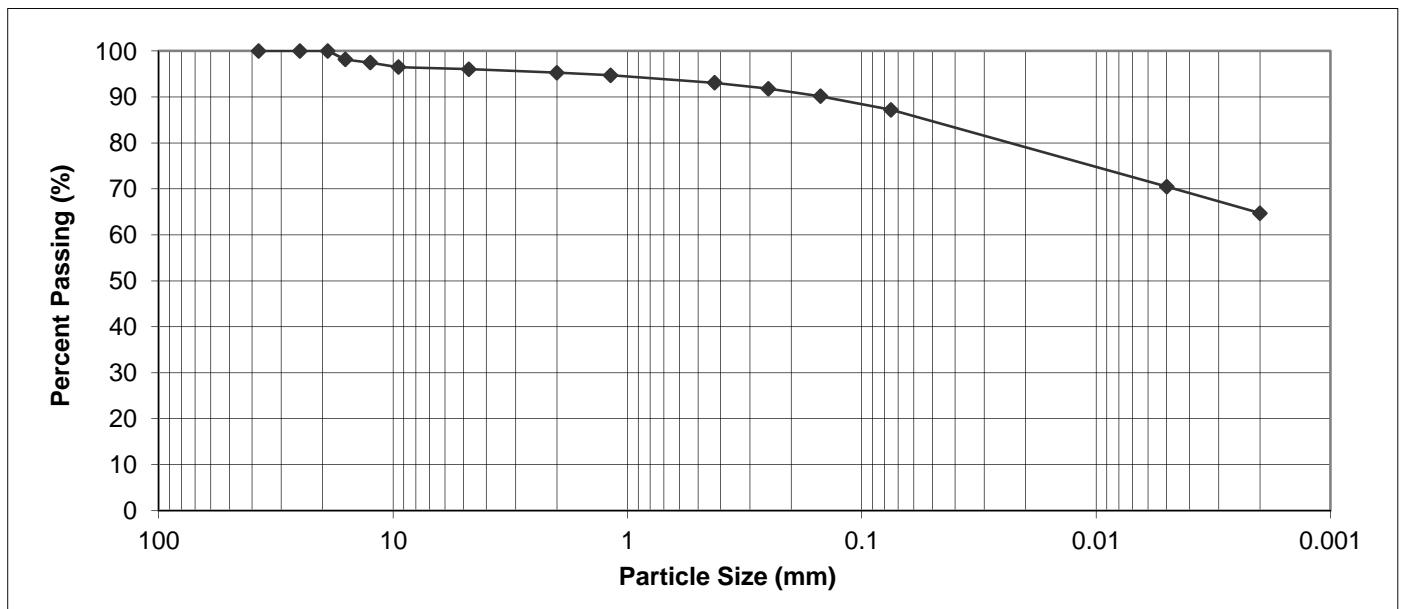

PARTICLE SIZE		PERCENT PASSING	PARTICLE SIZE		PERCENT PASSING	
37.50 mm		100.0	1.18 mm		94.7	
25.00 mm		100.0	0.425 mm		93.1	
19.00 mm		100.0	0.250 mm		91.8	
16.00 mm		98.2	0.150 mm		90.1	
12.50 mm		97.5	0.075 mm		87.2	
9.50 mm		96.5	0.005 mm		70.5	
4.75 mm		96.0	0.002 mm		64.7	
2.00 mm		95.3	0.001 mm		NT*	
Gravel, % 75 to 4.75 mm	Sand, %			Silt, % <0.075 to 0.005 mm	Clay, % <0.005 mm	Colloids, % < 0.001 mm
	Coarse <4.75 to 2.0 mm	Medium <2.0 to 0.425 mm	Fine <0.425 to 0.075 mm			
4.0	0.7	2.2	5.9	16.7	70.5	NT*

NT\* Sample not tested for colloids

July 5, 2012

REVIEWED BY: Farouk Fourar-Laidi, B.Sc., EIT



**THE  
NATIONAL  
TESTING  
LABORATORIES  
LIMITED**  
Established in 1923

# PARTICLE SIZE ANALYSIS ASTM D422

J.R. Cousin Consultants Ltd.  
91 A Scurfield Blvd  
Winnipeg, Manitoba  
R3Y 1G4

PROJECT: Woodlands Lagoon Expansion

Attention: Oswald Wohlgemut

PROJECT NO.: JRC-1209

SAMPLED BY: Client  
SAMPLE ID: TH3 2.5-5.4 m

DATE RECEIVED: June 27, 2012  
TESTED BY: Sothea Bun

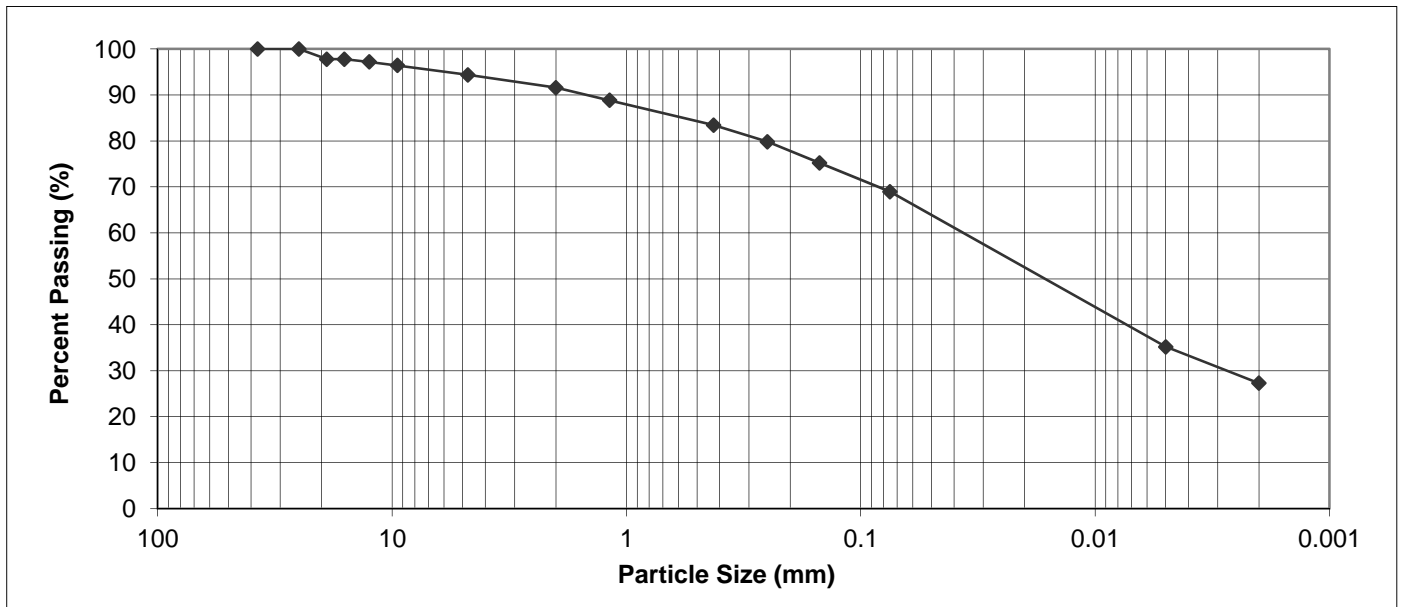

PARTICLE SIZE	PERCENT PASSING	PARTICLE SIZE	PERCENT PASSING
37.50 mm	100.0	1.18 mm	88.8
25.00 mm	100.0	0.425 mm	83.4
19.00 mm	97.8	0.250 mm	79.8
16.00 mm	97.8	0.150 mm	75.2
12.50 mm	97.2	0.075 mm	68.9
9.50 mm	96.4	0.005 mm	35.2
4.75 mm	94.4	0.002 mm	27.3
2.00 mm	91.6	0.001 mm	NT*

Gravel, % 75 to 4.75 mm	Sand, %			Silt, % <0.075 to 0.005 mm	Clay, % <0.005 mm	Colloids, % < 0.001 mm
	Coarse <4.75 to 2.0 mm	Medium <2.0 to 0.425 mm	Fine <0.425 to 0.075 mm			
5.6	2.8	8.2	14.5	33.7	35.2	NT*

NT\* Sample not tested for colloids

July 5, 2012

REVIEWED BY: Farouk Fourar-Laidi, B.Sc., EIT

# HYDRAULIC CONDUCTIVITY ASTM D5084

J. R. Cousin Consultants Ltd.  
91A Scurfield Blvd  
Winnipeg, MB  
R3Y 1G4

PROJECT: Woodlands Lagoon Exapansion

Attention: Oswald Wohlgemut

**SAMPLE I.D.:** TH3 1.0-2.5 m  
**SOIL TYPE:** Brown, stiff, moist, high plasticity clay, some silt, some sand, trace fine to coarse gravel  
**DATE TESTED:** June 29 to July 8, 2012  
**CONFINING PRESSURE (kPa):** 137.9  
**EFFECTIVE SATURATION STRESS (kPa):** 34.5  
**HYDRAULIC GRADIENT:** 19.6  
**TYPE OF PERMEANT LIQUID:** De-aired Water  
**HYDRAULIC CONDUCTIVITY, "k" (cm/s):** 9.9E-09  
**HYDRAULIC CONDUCTIVITY, "k<sub>20</sub>" (cm/s):** 9.2E-09

	Height (mm)	Diameter (mm)	Wet Mass (g)	Dry Density (g/cm <sup>3</sup> )	Water Content (%)	Saturation (%)
<b>Initial Reading</b>	74.6	72.7	608.9	1.549	27.0	97.5
<b>Final Reading</b>	75.6	72.8	622.9	1.521	30.0	104.0

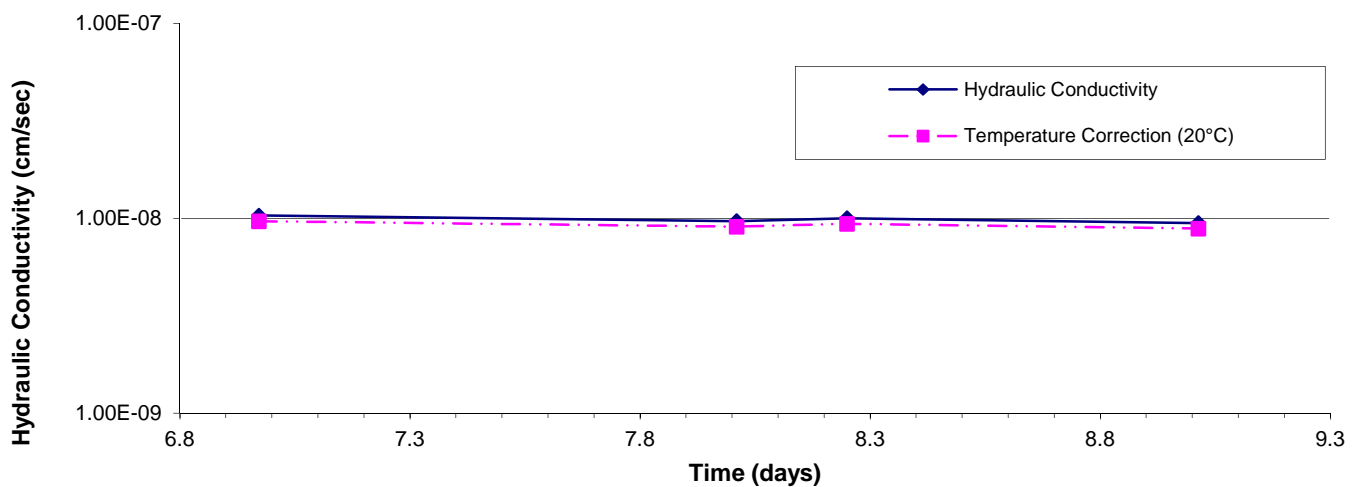

July 10, 2012

REVIEWED BY: Farouk Fourar-Laidi, B.Sc., EIT



## Driller's Well Logs

LOCATION: NW23-14-2W

Well\_PID: 6837  
Owner: E SMITH  
Driller: SONIC DRILLING CO. LTD  
Well Name:  
Well Use: PRODUCTION  
Water Use: Domestic  
UTMX: 597229.263  
UTMY: 5562625.65  
Accuracy XY: UNKNOWN  
UTMZ:  
Accuracy Z:  
Date Completed: 1965 Sep 01

WELL LOG

From (ft.)	To (ft.)	Log
0	4.0	GRAVEL
4.0	18.0	CLAY; HARD
18.0	49.0	CLAY AND BOULDERS
49.0	95.9	CLAY AND BOULDERS WITH GRAVEL STRINGERS
95.9	149.9	LIMESTONE
149.9	161.9	LIMESTONE FISSURES

WELL CONSTRUCTION

From (ft.)	To (ft.)	Casing Type	Inside Dia. (in)	Outside Dia. (in)	Slot Size (in)	Type	Material
0	97.9	casing	5.00				
97.9	161.9	open hole					

Top of Casing: ft. below ground

PUMPING TEST

Date:  
Pumping Rate: ?? Imp. gallons/minute  
Water level before pumping: 71.0 ft. below ground  
Pumping level at end of test: ?? ft. below ground  
Test duration: ??? hours, ?? minutes  
Water temperature: ?? degrees F

---

LOCATION: SW23-14-2W

Well\_PID: 116615  
Owner: BRUCE & DAVID LANGRELL  
Driller: Selkirk Drillers  
Well Name:  
Well Use: PRODUCTION

Water Use:       Livestock  
UTMX:        597244.513  
UTMY:        5561818.99  
Accuracy XY:  
UTMZ:  
Accuracy Z:  
Date Completed: 1999 Jun 28

WELL LOG

From (ft.)	To (ft.)	Log
0	3.0	GRAVEL FILL
3.0	10.0	GREY CLAY
10.0	20.0	SOFT AND SANDY TILL
20.0	50.0	TILL AND BOULDERS
50.0	175.0	LIMESTONE

WELL CONSTRUCTION

From (ft.)	To (ft.)	Casing Type	Inside Dia. (in)	Outside Dia. (in)	Slot Size (in)	Type	Material
0	55.0	CASING	5.00	5.50		INSERT	PVC
55.0	175.0	OPEN HOLE	4.80				

Top of Casing: 1.5 ft. above ground

PUMPING TEST

Date:                               1999 Jun 28  
Pumping Rate:                       20.0 Imp. gallons/minute  
Water level before pumping:        9.0 ft. below ground  
Pumping level at end of test:      ?? ft. below ground  
Test duration:                       ??? hours, ?? minutes  
Water temperature:                  ?? degrees F

REMARKS

R.M. OF WOODLANDS. CASING GROUTED

## **Appendix D**

Title Page

Plan L1: Proposed Lagoon Expansion Location Plan with Setbacks

Plan L2: Proposed Lagoon Expansion Layout with Test Hole Locations

Plan L3: Lagoon Discharge Route

Plan L4: Perimeter Dike and Transition Area

Plan L5: Lagoon Section West to East

Plan L6: Lagoon Section North to South

Plan L7: Valve, Valve Marker, Sign, Rip Rap and Ditch Details

Plan L8: Spillway, Truck Turnaround, Silt Fence, Gate and Lock Details

# R.M. OF WOODLANDS

## LAGOON

### ENVIRONMENT ACT PROPOSAL

**PRELIMINARY**  
NOT FOR CONSTRUCTION

#### PLAN INDEX

##### LAGOON

- PLAN L1. PROPOSED LAGOON EXPANSION LOCATION PLAN WITH SETBACKS
- PLAN L2. PROPOSED LAGOON EXPANSION LAYOUT WITH TEST HOLE LOCATIONS
- PLAN L3. LAGOON DRAINAGE ROUTE
- PLAN L4. PERIMETER DIKE AND TRANSITION AREA
- PLAN L5. LAGOON SECTION WEST TO EAST
- PLAN L6. LAGOON SECTION NORTH TO SOUTH
- PLAN L7. VALVE, VALVE MARKER, SIGN, RIP RAP, DITCH AND SILT FENCE DETAILS
- PLAN L8. SPILLWAY, TRUCK TURNAROUND, FENCE, GATE AND LOCK DETAILS

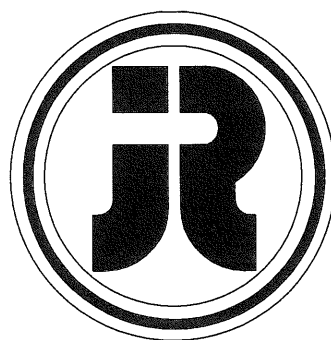

**J. R. Cousin Consultants Ltd.**  
Consulting Engineers and Project Managers

91A Scurfield Blvd.  
ph: (204) 489-0474  
email: [info@jrcc.ca](mailto:info@jrcc.ca)

Winnipeg, MB R3Y 1G4  
fax: (204) 489-0487  
website: [www.jrcc.ca](http://www.jrcc.ca)

*Engineering Excellence since 1981*





**PRELIMINARY**  
NOT FOR CONSTRUCTION

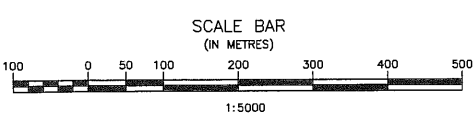

No.	REVISIONS	DATE	INITIALS

B.M. EL.

LOCATIONS OF UNDERGROUND STRUCTURES/UTILITIES AS SHOWN ARE BASED ON AVAILABLE INFORMATION BUT NO GUARANTEE IS GIVEN OR IMPLIED THAT ALL EXISTING UNDERGROUND STRUCTURES/UTILITIES ARE SHOWN OR THAT THE GIVEN LOCATIONS ARE EXACT. CONFIRMATION OF EXISTENCE AND EXACT LOCATION OF ALL UNDERGROUND STRUCTURES/UTILITIES MUST BE OBTAINED FROM THE APPROPRIATE AUTHORITY/OWNER, BY THE CONTRACTOR, BEFORE PROCEEDING WITH CONSTRUCTION.

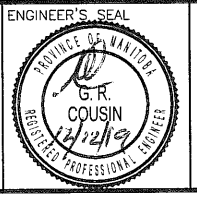

**J. R. Cousin Consultants Ltd.**  
Consulting Engineers and Project Managers

91A Scurfield Blvd. Winnipeg, MB R3Y 1G4  
ph: (204) 489-0474 fax: (204) 489-0487  
email: info@jrcc.ca website: www.jrcc.ca

*Engineering Excellence since 1981*

CODE:	W-210.25	PROJECT:	R.M. OF WOODLANDS ENVIRONMENT ACT PROPOSAL
DESIGNED BY:	OW	TITLE:	PROPOSED LAGOON EXPANSION LOCATION PLAN WITH SETBACKS
DRAWN BY:	OT	SCALE:	1:5000
REVIEWED BY:	JC	DATE:	12/11/27
		PLAN:	L1
		SHEET:	1 of 8

Doc 18\_2012 - 250mm PLOT/310 Woodlands - R\311225 Woodlands Lagoon - R\311225 Woodlands Lagoon Expansion Location Plan.rvt



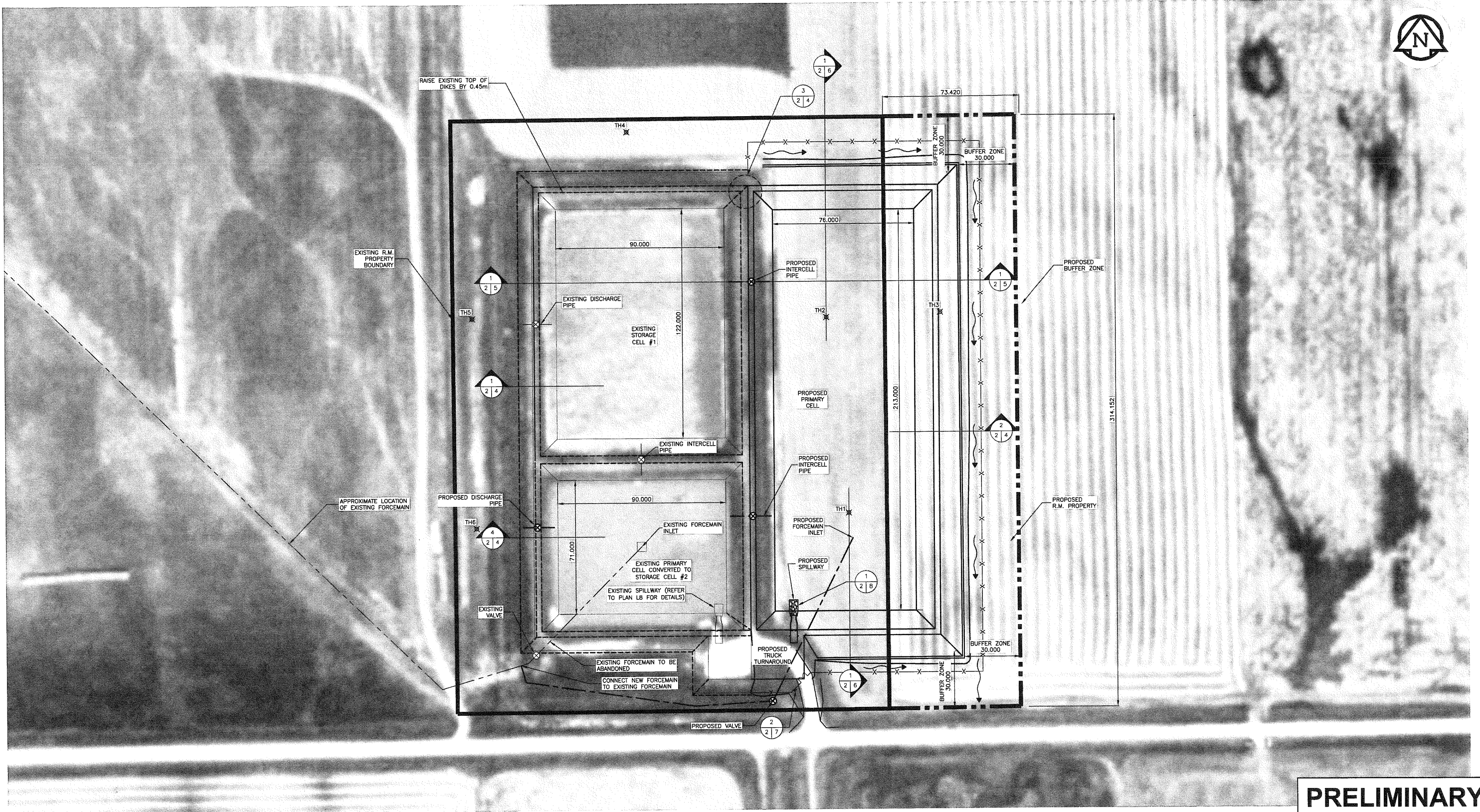

**PRELIMINARY  
NOT FOR CONSTRUCTION**

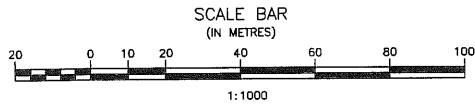

No.	REVISIONS	DATE	INITIALS

B.M. EL.

LOCATIONS OF UNDERGROUND STRUCTURES/UTILITIES AS SHOWN ARE BASED ON AVAILABLE INFORMATION BUT NO GUARANTEE IS GIVEN OR IMPLIED THAT ALL EXISTING UNDERGROUND STRUCTURES/UTILITIES ARE SHOWN OR THAT THE GIVEN LOCATIONS ARE EXACT. CONFIRMATION OF EXISTENCE AND EXACT LOCATION OF ALL UNDERGROUND STRUCTURES/UTILITIES MUST BE OBTAINED FROM THE APPROPRIATE AUTHORITY/OWNER, BY THE CONTRACTOR, BEFORE PROCEEDING WITH CONSTRUCTION.

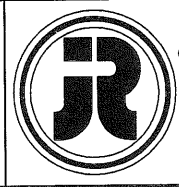

**J. R. Cousin Consultants Ltd.**  
Consulting Engineers and Project Managers

91A Scurfield Blvd. Winnipeg, MB R3Y 1G4  
ph: (204) 489-0474 fax: (204) 489-0487  
email: info@jrcc.ca website: www.jrcc.ca

*Engineering Excellence since 1981*

CODE:	W-210.25	PROJECT:	R.M. OF WOODLANDS ENVIRONMENT ACT PROPOSAL
DESIGNED BY:	OW	TITLE:	PROPOSED LAGOON EXPANSION LAYOUT WITH TEST HOLE LOCATIONS
DRAWN BY:	OT	SCALE:	1:1000
REVIEWED BY:	OW	DATE:	12/11/27
		PLAN:	L2
		SHEET:	2 of 8

Due 16, 2017 - 3:00pm 13/07/16 Woodlands - R.M. of Woodlands - Environment Act Proposal - Proposed Lagoon Expansion Layout - Planning  
 R031013 Woodlands Lagoon Expansion Planning - R.M. of Woodlands - Environment Act Proposal - Proposed Lagoon Expansion Layout - Planning



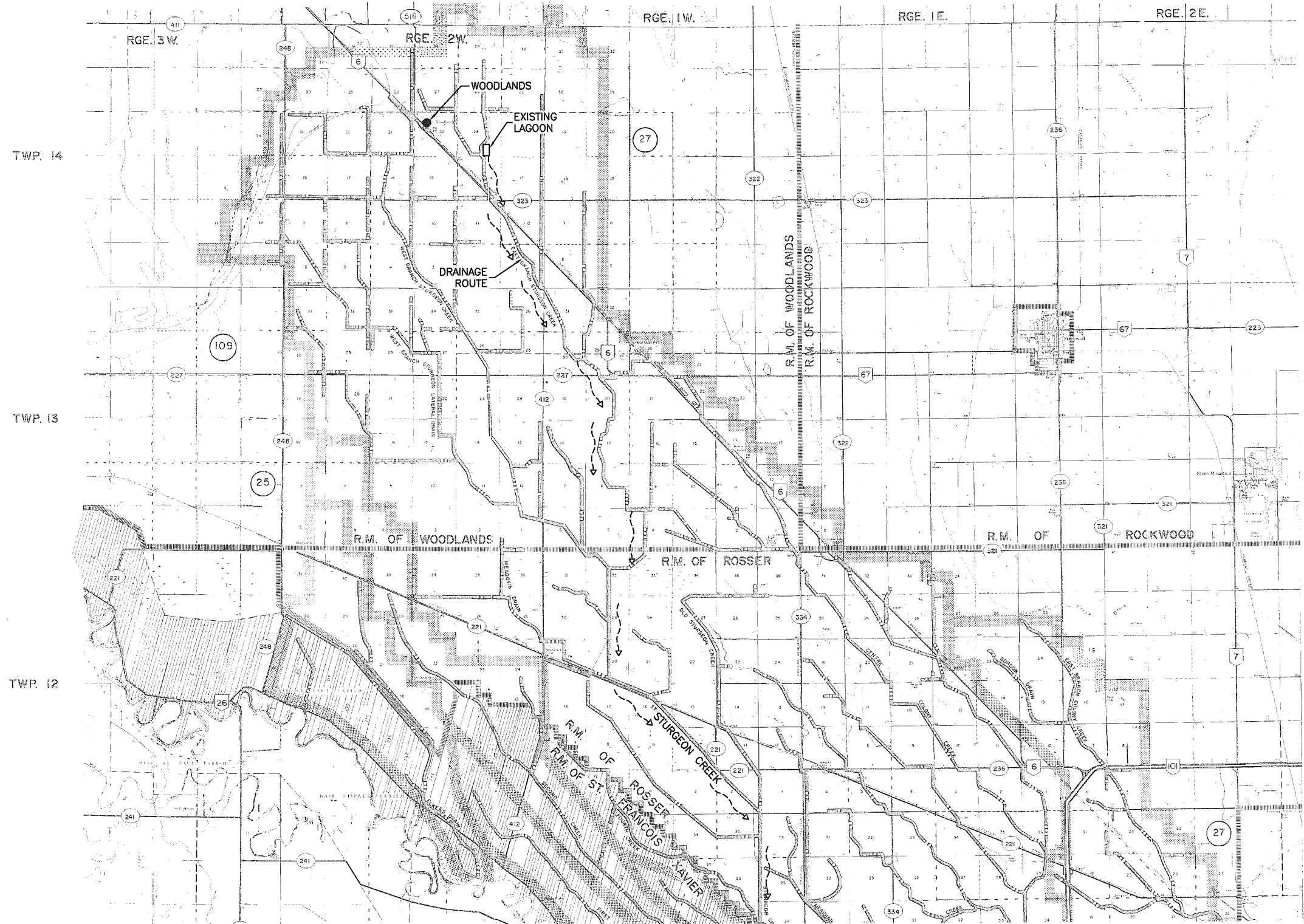

**LEGEND:**  
 - - - - -> EXISTING DRAINAGE

**PRELIMINARY**  
 NOT FOR CONSTRUCTION

No.	REVISIONS	DATE	INITIALS

B.M. EL.  
 LOCATIONS OF UNDERGROUND STRUCTURES/UTILITIES AS SHOWN ARE BASED ON AVAILABLE INFORMATION BUT NO GUARANTEE IS GIVEN OR IMPLIED THAT ALL EXISTING UNDERGROUND STRUCTURES/UTILITIES ARE SHOWN OR THAT THE GIVEN LOCATIONS ARE EXACT. CONFIRMATION OF EXISTENCE AND EXACT LOCATION OF ALL UNDERGROUND STRUCTURES/UTILITIES MUST BE OBTAINED FROM THE APPROPRIATE AUTHORITY/OWNER, BY THE CONTRACTOR, BEFORE PROCEEDING WITH CONSTRUCTION.

ENGINEER'S SEAL  
**PRELIMINARY**









**J. R. Cousin Consultants Ltd.**  
 Consulting Engineers and Project Managers  
 91A Scurfield Blvd. Winnipeg, MB R3Y 1G4  
 ph: (204) 489-0474 fax: (204) 489-0487  
 email: info@jrcc.ca website: www.jrcc.ca  
*Engineering Excellence since 1981*

CODE:	W-210.25	PROJECT:	R.M. OF WOODLANDS ENVIRONMENT ACT PROPOSAL
DESIGNED BY:	OW	TITLE:	LAGOON DRAINAGE ROUTE
DRAWN BY:	OT	SCALE:	NTS
REVIEWED BY:	JC	DATE:	12/11/27
		PLAN:	L3
		SHEET:	3 of 8

Dec 18, 2013 - 3:13pm F:\2013\10 - Woodlands Lagoon\DWG\DWG\1025 - Woodlands Lagoon\DWG\DWG\1025 - Lagoon Drainage Routing



**LEGEND:**

-  EXCAVATED AND COMPACTED HIGH PLASTIC CLAY TYPE SOIL
-  EXCAVATED AND COMPACTED SOIL MATERIAL
-  INSITU SANDY CLAY SOIL
-  TOPSOIL
-  EXCAVATED AND COMPACTED MIXTURE OF SOILS
-  INSITU HIGH PLASTIC SOIL

- LEVEL 1 - PRE-CONSTRUCTION EXISTING PRAIRIE ELEVATION
- LEVEL 2 - ELEVATION FOLLOWING REMOVAL OF ORGANICS
- LEVEL 3 - FINISHED CELL BOTTOM ELEVATION
- LEVEL 4 - BOTTOM OF LINER ELEVATION

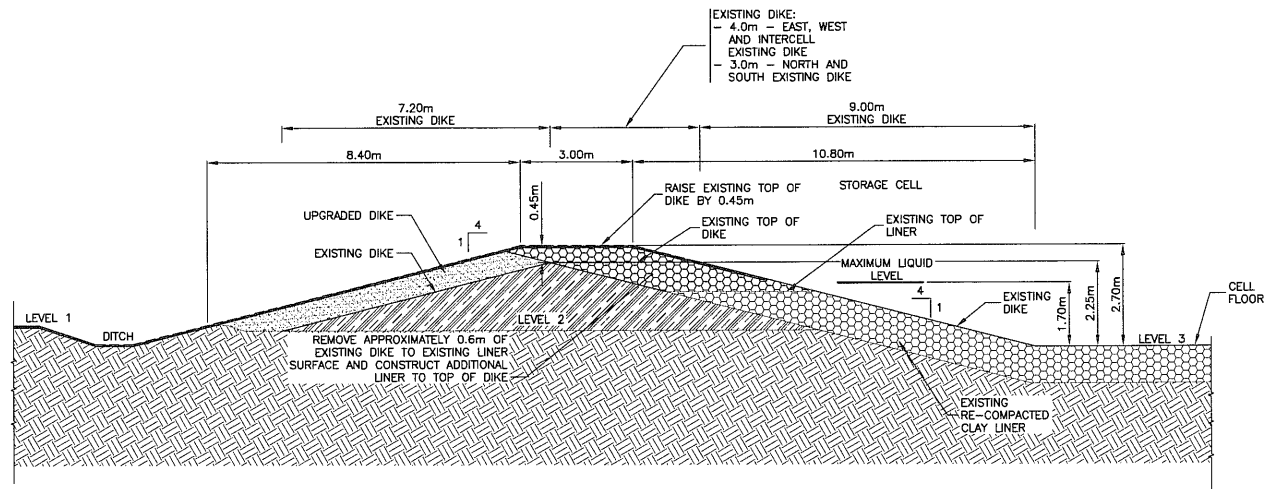

1  
2/4 TYPICAL STORAGE CELL PERIMETER DIKE UPGRADE  
SCALE = 1:100

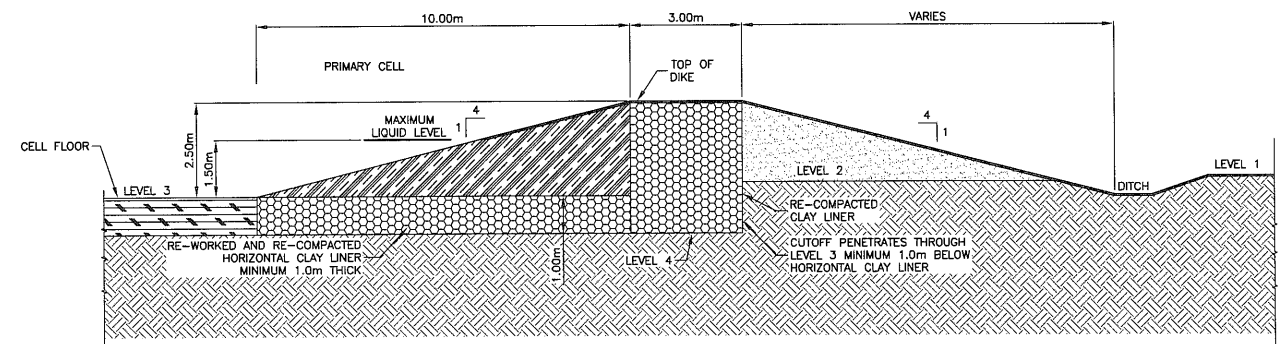

2  
2/4 TYPICAL PRIMARY CELL PERIMETER DIKE  
SCALE = 1:100

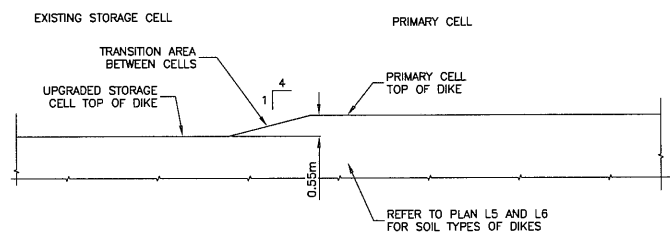

3  
2/4 TYPICAL TRANSITION AREA BETWEEN EXISTING AND PROPOSED CELLS  
SCALE = 1:100

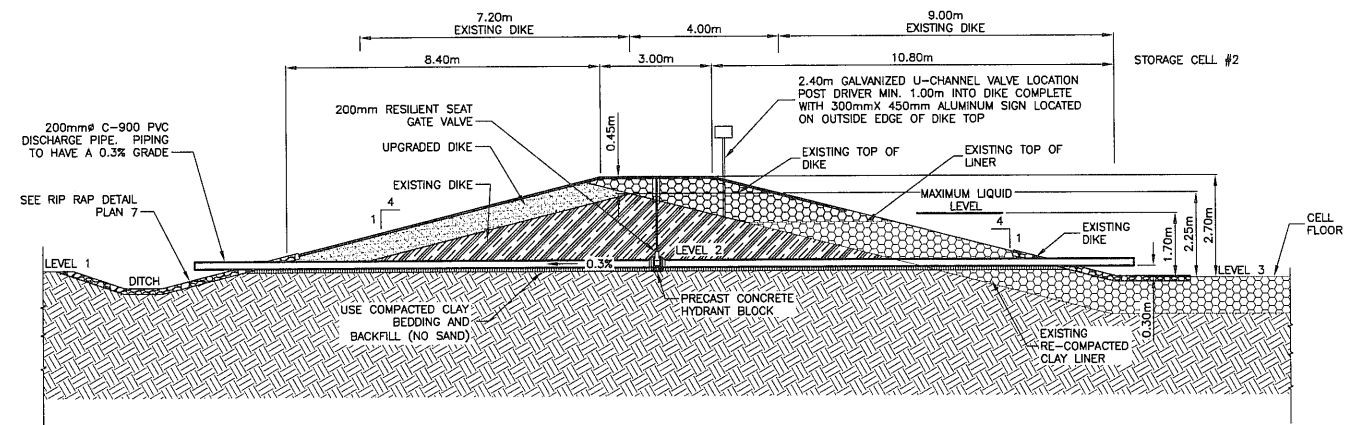

4  
2/4 PERIMETER DIKE AT DISCHARGE PIPE  
SCALE = 1:100

**PRELIMINARY**  
**NOT FOR CONSTRUCTION**

					B.M. EL.
No.	REVISIONS	DATE	INITIALS		

LOCATIONS OF UNDERGROUND STRUCTURES/UTILITIES AS SHOWN ARE BASED ON AVAILABLE INFORMATION BUT NO GUARANTEE IS GIVEN OR IMPLIED THAT ALL EXISTING UNDERGROUND STRUCTURES/UTILITIES ARE SHOWN OR THAT THE GIVEN LOCATIONS ARE EXACT. CONFIRMATION OF EXISTENCE AND EXACT LOCATION OF ALL UNDERGROUND STRUCTURES/UTILITIES MUST BE OBTAINED FROM THE APPROPRIATE AUTHORITY/OWNER, BY THE CONTRACTOR, BEFORE PROCEEDING WITH CONSTRUCTION.

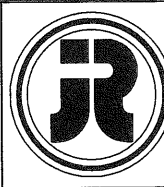
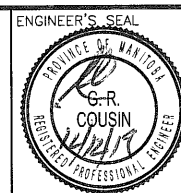

**J. R. Cousin Consultants Ltd.**  
Consulting Engineers and Project Managers  
91A Scurfield Blvd. Winnipeg, MB R3Y 1G4  
ph: (204) 489-0474 fax: (204) 489-0487  
email: info@jrcc.ca website: www.jrcc.ca  
*Engineering Excellence since 1981*

CODE:	W-210.25	PROJECT:	R.M. OF WOODLANDS ENVIRONMENT ACT PROPOSAL
DESIGNED BY:	OW	TITLE:	PERIMETER DIKE AND TRANSITION AREA
DRAWN BY:	OT	SCALE:	1:100
REVIEWED BY:	JC	DATE:	12/11/28
		PLAN:	L4
		SHEET:	4 of 8

**LEGEND:**

- |  |   |  |  |
|--|---|--|--|
|  | EXCAVATED AND COMPACTED HIGH PLASTIC CLAY TYPE SOIL |  | TOPSOIL                                  |
|  | EXCAVATED AND COMPACTED SOIL MATERIAL               |  | EXCAVATED AND COMPACTED MIXTURE OF SOILS |
|  | INSITU SANDY CLAY SOIL                              |  | INSITU HIGH PLASTIC SOIL                 |

- |   |
|---|
| LEVEL 1 - PRE-CONSTRUCTION EXISTING PRAIRIE ELEVATION |
| LEVEL 2 - ELEVATION FOLLOWING REMOVAL OF ORGANICS     |
| LEVEL 3 - FINISHED CELL BOTTOM ELEVATION              |
| LEVEL 4 - BOTTOM OF LINER ELEVATION                   |

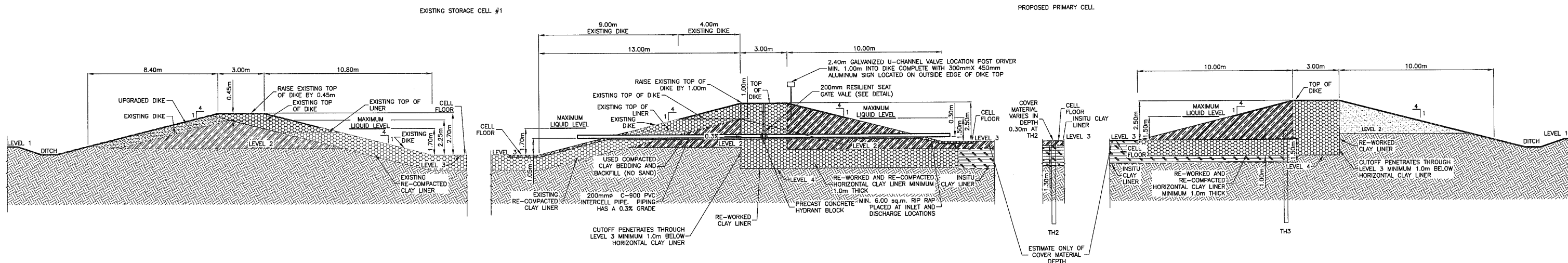

**CELL FLOOR AND LINER NOTES:**

- DEPTH OF COVER MATERIAL OVER IN-SITU LINER IS ONLY KNOWN AT TH2 AND TH3 LOCATIONS.
- DEPTH OF COVER MATERIAL IN OTHER SECTIONS OF PRIMARY CELL IS AN ESTIMATE ONLY, BASED ON FINDINGS IN TH2 AND TH3.
- VERTICAL CUT-OFF WALL CONSTRUCTED AT OUTSIDE TOP EDGE OF EXISTING CELL DIKE.

1  
2 5 TYPICAL LAGOON SECTION WEST TO EAST  
SCALE = 1:125

**PRELIMINARY**  
NOT FOR CONSTRUCTION

				B.M. EL.	ENGINEER'S SEAL		 <b>J. R. Cousin Consultants Ltd.</b> Consulting Engineers and Project Managers 91A Scurfield Blvd. Winnipeg, MB R3Y 1G4 ph: (204) 489-0474 fax: (204) 489-0487 email: info@jrcc.ca website: www.jrcc.ca <i>Engineering Excellence since 1981</i>		CODE: W-210.25 DESIGNED BY: OW DRAWN BY: OT REVIEWED BY: JC	PROJECT: R.M. OF WOODLANDS ENVIRONMENT ACT PROPOSAL TITLE: LAGOON SECTION WEST TO EAST SCALE: 1:125 DATE: 12/12/03 PLAN: L5 SHEET: 5 of 8
No.	REVISIONS	DATE	INITIALS	LOCATIONS OF UNDERGROUND STRUCTURES/UTILITIES AS SHOWN ARE BASED ON AVAILABLE INFORMATION BUT NO GUARANTEE IS GIVEN OR IMPLIED THAT ALL EXISTING UNDERGROUND STRUCTURES/UTILITIES ARE SHOWN OR THAT THE GIVEN LOCATIONS ARE EXACT. CONFIRMATION OF EXISTENCE AND EXACT LOCATION OF ALL UNDERGROUND STRUCTURES/UTILITIES MUST BE OBTAINED FROM THE APPROPRIATE AUTHORITY/OWNER, BY THE CONTRACTOR, BEFORE PROCEEDING WITH CONSTRUCTION.						

**LEGEND:**

- |  |   |  |  |
|--|---|--|--|
|  | EXCAVATED AND COMPACTED HIGH PLASTIC CLAY TYPE SOIL |  | TOPSOIL                                  |
|  | EXCAVATED AND COMPACTED SOIL MATERIAL               |  | EXCAVATED AND COMPACTED MIXTURE OF SOILS |
|  | INSITU SANDY CLAY SOIL                              |  | INSITU HIGH PLASTIC SOIL                 |

LEVEL 1 - PRE-CONSTRUCTION EXISTING PRAIRIE ELEVATION  
 LEVEL 2 - ELEVATION FOLLOWING REMOVAL OF ORGANICS  
 LEVEL 3 - FINISHED CELL BOTTOM ELEVATION  
 LEVEL 4 - BOTTOM OF LINER ELEVATION

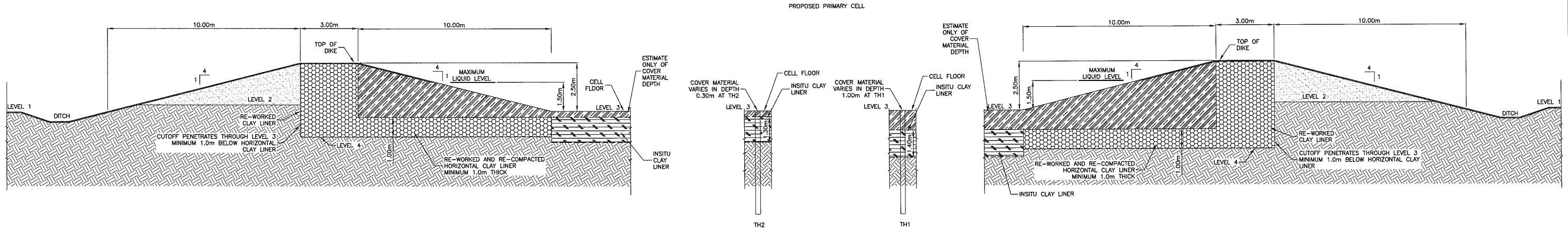

**CELL FLOOR AND LINER NOTES:**

- DEPTH OF COVER MATERIAL OVER IN-SITU LINER IS ONLY KNOWN AT TH1 AND TH2 LOCATIONS.
- DEPTH OF COVER MATERIAL IN OTHER SECTIONS OF PRIMARY CELL IS AN ESTIMATE ONLY, BASED ON FINDINGS IN TH1 AND TH2.

1 TYPICAL LAGOON SECTION NORTH TO SOUTH  
 2 6 SCALE = 1:100

**PRELIMINARY**  
**NOT FOR CONSTRUCTION**

No.	REVISIONS	DATE	INITIALS	B.M. EL.

LOCATIONS OF UNDERGROUND STRUCTURES/UTILITIES AS SHOWN ARE BASED ON AVAILABLE INFORMATION BUT NO GUARANTEE IS GIVEN OR IMPLIED THAT ALL EXISTING UNDERGROUND STRUCTURES/UTILITIES ARE SHOWN OR THAT THE GIVEN LOCATIONS ARE EXACT. CONFIRMATION OF EXISTENCE AND EXACT LOCATION OF ALL UNDERGROUND STRUCTURES/UTILITIES MUST BE OBTAINED FROM THE APPROPRIATE AUTHORITY/OWNER, BY THE CONTRACTOR, BEFORE PROCEEDING WITH CONSTRUCTION.

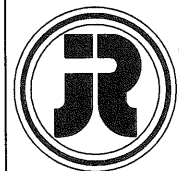
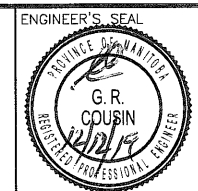

**J. R. Cousin Consultants Ltd.**  
 Consulting Engineers and Project Managers  
 91A Scurfield Blvd. Winnipeg, MB R3Y 1G4  
 ph: (204) 489-0474 fax: (204) 489-0487  
 email: info@jrcc.ca website: www.jrcc.ca  
*Engineering Excellence since 1981*

CODE: W-210.25	PROJECT: R.M. OF WOODLANDS ENVIRONMENT ACT PROPOSAL
DESIGNED BY: OW	TITLE: LAGOON SECTION NORTH TO SOUTH
DRAWN BY: OT	SCALE: 1:100 DATE: 12/12/03 PLAN: L6 SHEET: 6 of 8
REVIEWED BY: JC	

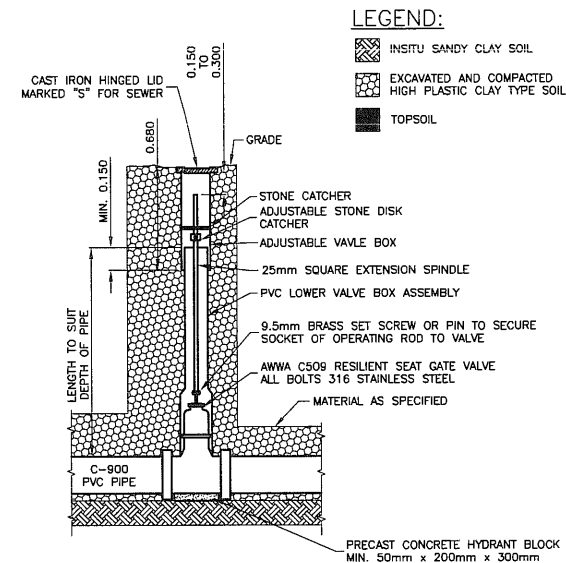
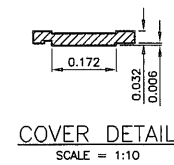

1 LAGOON DIKE VALVE DETAIL  
SCALE = 1:25

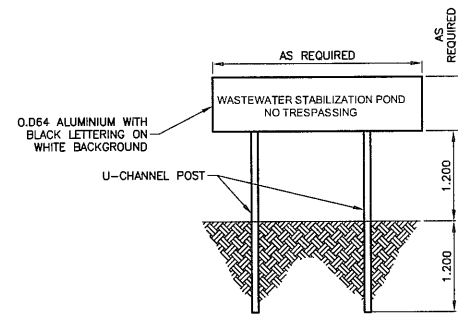

2 LAGOON SITE MARKER DETAIL  
SCALE = 1:50

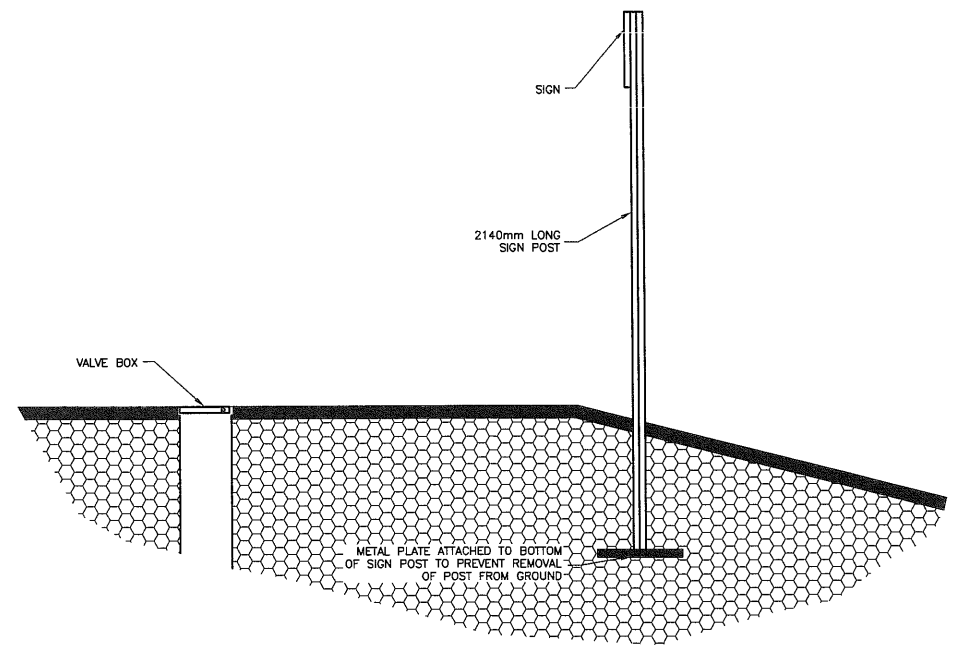

NOTES:  
 - MINIMUM SIGN SIZE: 300mm X 450mm  
 - MINIMUM POST LENGTH: 2140mm  
 - CROSSING MARKERS TO BE SET IN 200mm X 1.0m CONCRETE AS PER SPECIFICATIONS

3 VALVE MARKER DETAIL  
SCALE = 1:15

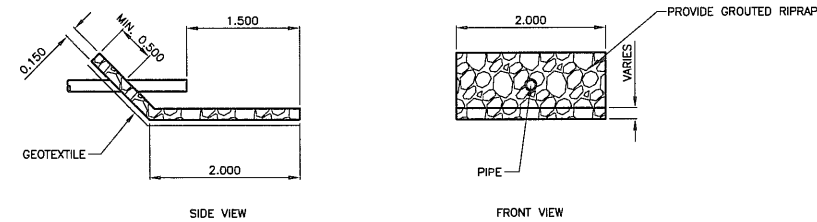

NOTE:  
 -RIPRAP MATERIAL SHALL BE WELL GRADED 125mm TO 200mm HARD, DENSE, ROUNDED & DURABLE FIELD STONE.

4 RIPRAP DETAIL  
SCALE = 1:50

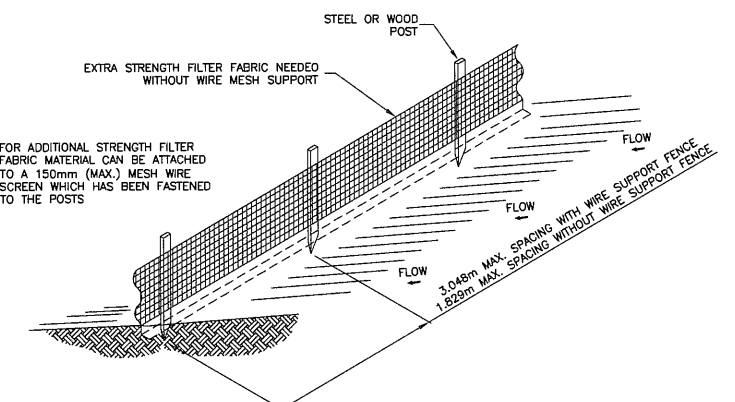

- NOTES:
1. THE HEIGHT OF A SILT FENCE SHALL NOT EXCEED 914mm.
  2. THE FILTER FABRIC SHALL BE PURCHASED IN A CONTINUOUS ROLL CUT TO THE LENGTH OF THE BARRIER TO AVOID THE USE OF JOINTS.
  3. POSTS SHALL BE SPACED A MAXIMUM OF 3.048m APART AT THE BARRIER LOCATION AND DRIVEN SECURELY INTO THE GROUND A MINIMUM OF 300mm. WHEN EXTRA STRENGTH FABRIC IS USED WITHOUT THE WIRE SUPPORT FENCE, POST SPACING SHALL NOT EXCEED 1.829m.
  4. A TRENCH SHALL BE EXCAVATED APPROXIMATELY 100mm WIDE AND 100mm DEEP ALONG THE LINE OF POSTS AND UPSLOPE FROM THE BARRIER.
  5. WHEN STANDARD STRENGTH FILTER FABRIC IS USED, A WIRE MESH SUPPORT FENCE SHALL BE FASTENED SECURELY TO THE UPSLOPE SIDE OF THE POSTS USING HEAVY DUTY WIRE STAPLES AT LEAST 25mm LONG, TIE WIRES, OR HOG RINGS. THE WIRE SHALL EXTEND INTO THE TRENCH A MINIMUM OF 50mm AND SHALL NOT EXTEND MORE THAN 914mm ABOVE THE ORIGINAL GROUND SURFACE.
  6. THE STANDARD STRENGTH FILTER FABRIC SHALL BE STAPLED OR WIRED TO THE FENCE, AND 200mm OF THE FABRIC SHALL BE EXTENDED INTO THE TRENCH. THE FABRIC SHALL NOT EXTEND MORE THAN 914mm ABOVE THE ORIGINAL GROUND SURFACE.
  7. THE TRENCH SHALL BE BACKFILLED AND THE SOIL COMPACTED OVER THE FILTER FABRIC.
  8. SILT FENCING TO BE POLYPROPYLENE SYNTHETIC FIBRE WITH ULTRAVIOLET STABILIZERS. AMOCO 1198 OR APPROVED EQUAL.
  9. WOOD POSTS TO BE 38mm X 89mm (2" X 4"), POINTED AT ONE END AND FABRICATED.
  10. INSTALL ALL SUPPORTING POSTS ON THE DOWN SLOPE SIDE OF THE FENCING
  11. MAINTAIN SILT FENCE THROUGHOUT CONSTRUCTION AND UNTIL REVEGETATION OCCURS.

6 SILT FENCE DETAIL  
SCALE = 1:40

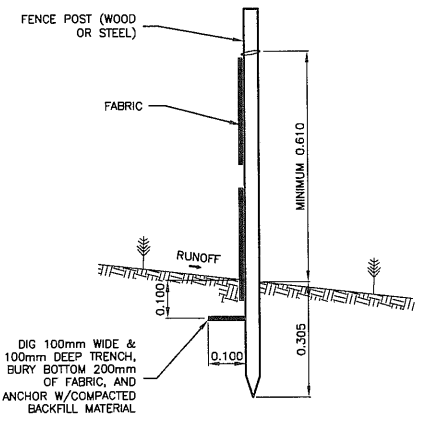

7 SILT FENCE SECTION  
SCALE = 1:10

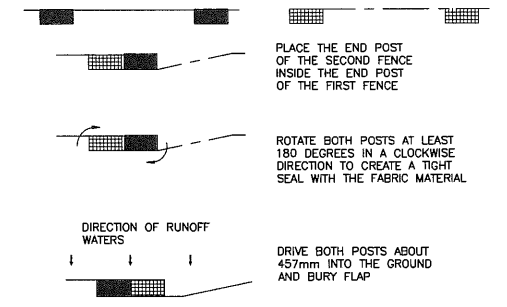

8 ATTACHING TWO SILT FENCES  
SCALE = 1:10

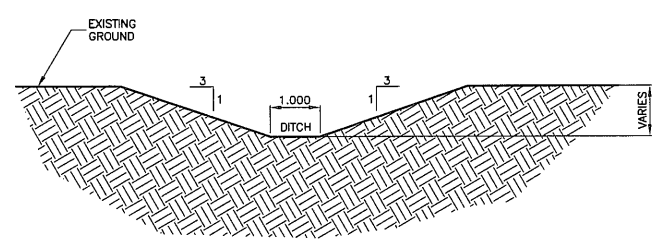

5 TYPICAL DISCHARGE DITCH DETAIL  
SCALE = 1:75

**PRELIMINARY**  
**NOT FOR CONSTRUCTION**

No.	REVISIONS	DATE	INITIALS	B.M. EL.	LOCATIONS OF UNDERGROUND STRUCTURES/UTILITIES AS SHOWN ARE BASED ON AVAILABLE INFORMATION BUT NO GUARANTEE IS GIVEN OR IMPLIED THAT ALL EXISTING UNDERGROUND STRUCTURES/UTILITIES ARE SHOWN OR THAT THE GIVEN LOCATIONS ARE EXACT. CONFIRMATION OF EXISTENCE AND EXACT LOCATION OF ALL UNDERGROUND STRUCTURES/UTILITIES MUST BE OBTAINED FROM THE APPROPRIATE AUTHORITY/OWNER, BY THE CONTRACTOR, BEFORE PROCEEDING WITH CONSTRUCTION.

ENGINEER'S SEAL  
**G. R. COUSIN**  
 REGISTERED PROFESSIONAL ENGINEER

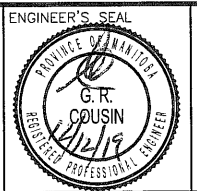

**J. R. Cousin Consultants Ltd.**  
 Consulting Engineers and Project Managers  
 91A Scurfield Blvd. Winnipeg, MB R3Y 1G4  
 ph: (204) 489-0474 fax: (204) 489-0487  
 email: info@jrcc.ca website: www.jrcc.ca  
 Engineering Excellence since 1981

CODE:	W-210.25	PROJECT:	R.M. OF WOODLANDS ENVIRONMENT ACT PROPOSAL
DESIGNED BY:	OW	TITLE:	VALVE, VALVE MARKER, SIGN, RIP RAP, DITCH AND SILT FENCE DETAILS
DRAWN BY:	OT	SCALE:	AS NOTED
REVIEWED BY:	JC	DATE:	12/12/10
		PLAN:	L7
		SHEET:	7 of 8

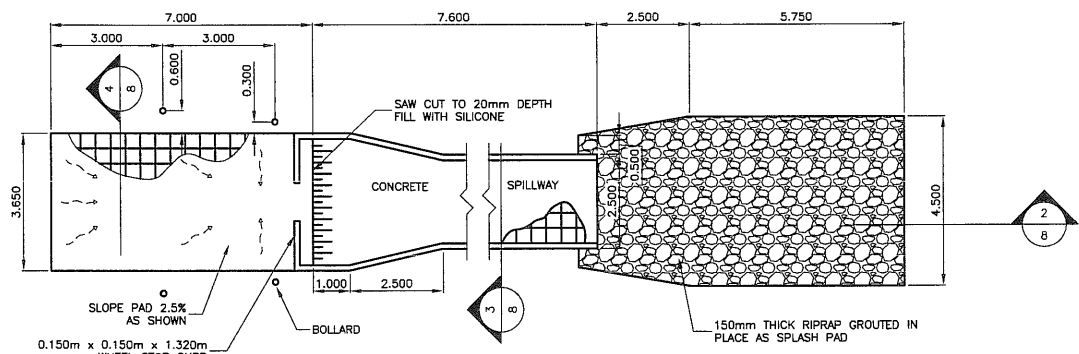

1 SPILLWAY PLAN VIEW  
SCALE = 1:100

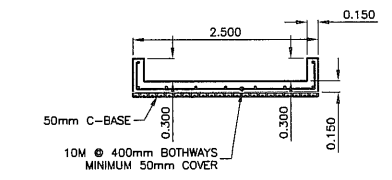

3 CONCRETE SPILLWAY SECTION  
SCALE = 1:50

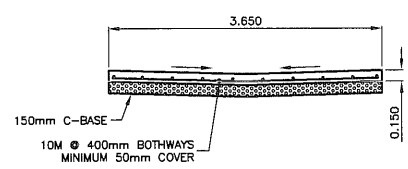

4 CONCRETE PAD SECTION  
SCALE = 1:50

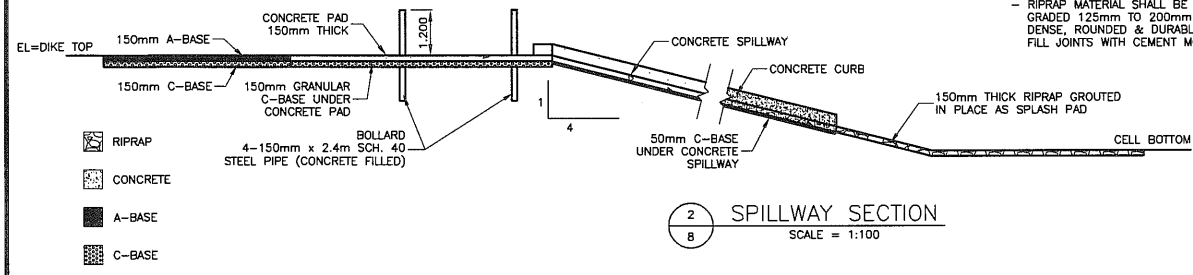

2 SPILLWAY SECTION  
SCALE = 1:100

RIPRAP NOTE:  
- RIPRAP MATERIAL SHALL BE WELL GRADED 125mm TO 200mm HARD, DENSE ROUNDED & DURABLE FIELD STONE. FILL JOINTS WITH CEMENT MORTAR.

CONCRETE NOTE:  
CONCRETE SHALL BE:  
- TYPE HS PORTLAND CEMENT MINIMUM 28 DAY COMPRESSION OF 20 MPa  
- 5-7% AIR CONTENT  
- MAXIMUM AGGREGATE SIZE OF 20mm  
- MAXIMUM SLUMP OF 100mm

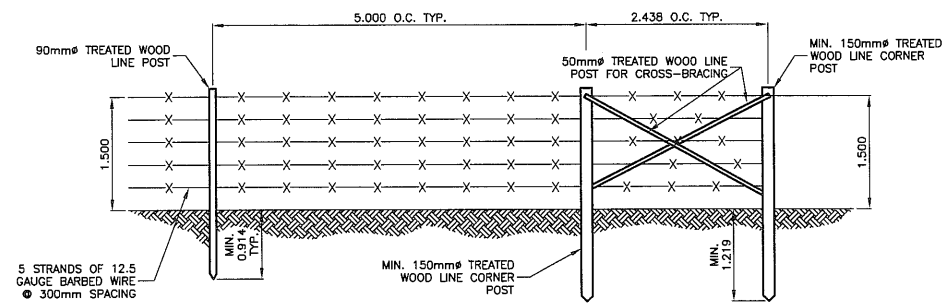

NOTE:  
- PROVIDE CROSS BRACING AT CORNER POSTS IN BOTH DIRECTIONS.  
- SHOWN DIAMETER REFERS TO SMALLEST END OF POST.

10 CORNER FENCE DETAIL  
SCALE = 1:50

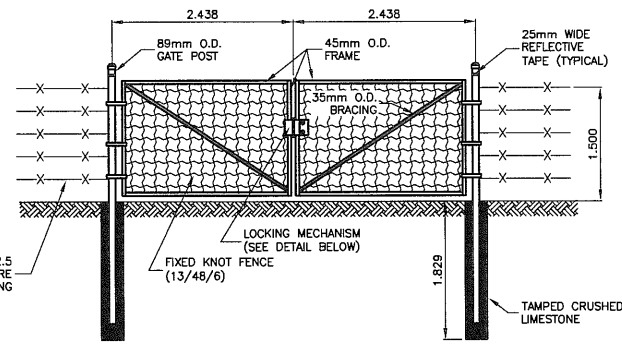

8 GATE DETAIL  
SCALE = 1:50

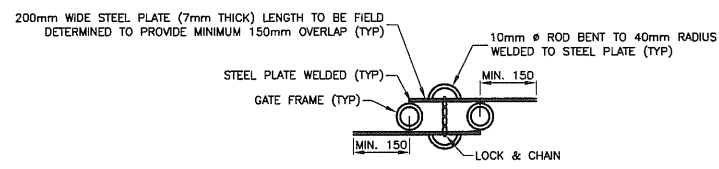

9 LOCK DETAIL  
SCALE = 1:10

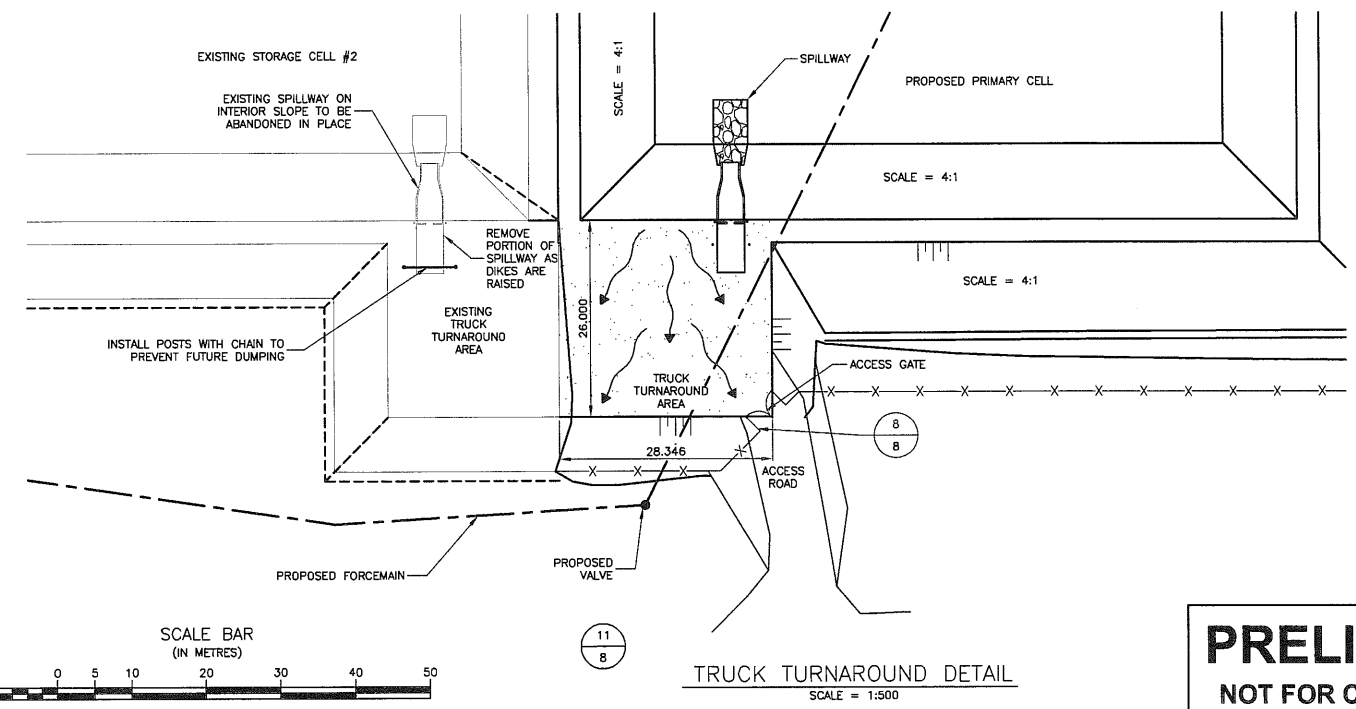

11 TRUCK TURNAROUND DETAIL  
SCALE = 1:500

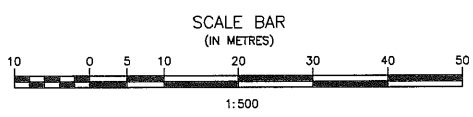

**PRELIMINARY**  
NOT FOR CONSTRUCTION

No.	REVISIONS	DATE	INITIALS

B.M. EL.

LOCATIONS OF UNDERGROUND STRUCTURES/UTILITIES AS SHOWN ARE BASED ON AVAILABLE INFORMATION BUT NO GUARANTEE IS GIVEN OR IMPLIED THAT ALL EXISTING UNDERGROUND STRUCTURES/UTILITIES ARE SHOWN OR THAT THE GIVEN LOCATIONS ARE EXACT. CONFIRMATION OF EXISTENCE AND EXACT LOCATION OF ALL UNDERGROUND STRUCTURES/UTILITIES MUST BE OBTAINED FROM THE APPROPRIATE AUTHORITY/OWNER, BY THE CONTRACTOR, BEFORE PROCEEDING WITH CONSTRUCTION.

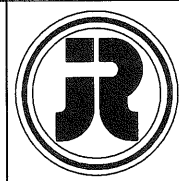
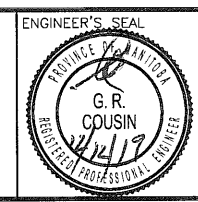

**J. R. Cousin Consultants Ltd.**  
Consulting Engineers and Project Managers

91A Scurfield Blvd. Winnipeg, MB R3Y 1G4  
ph: (204) 489-0474 fax: (204) 489-0487  
email: info@jrcc.ca website: www.jrcc.ca

Engineering Excellence since 1981

CODE: W-210.25	DESIGNED BY: OW	PROJECT: R.M. OF WOODLANDS ENVIRONMENT ACT PROPOSAL
DRAWN BY: OT	TITLE: SPILLWAY, TRUCK TURNAROUND, FENCE, GATE AND LOCK DETAILS	SCALE: AS NOTED
REVIEWED BY: JC	DATE: 12/12/10	PLAN: L8
		SHEET: 8 of 8